

RAD Conversion Update – Munro Mannor

Rental Assistance Demonstration

March 19, 2026

*Presented by:
Nicole Damm AVP of Property Management
King County Housing Authority*





RAD Overview



What is **RAD**?

Rental **Assistance Demonstration (RAD)**

A program created by the U.S. Department of **Housing and Urban Development (HUD)** that gives public housing authorities new flexibility to preserve and improve public housing properties like yours.



How does **RAD** work?

RAD changes the **source** of rental assistance from **public housing** to **Section 8** project-based vouchers

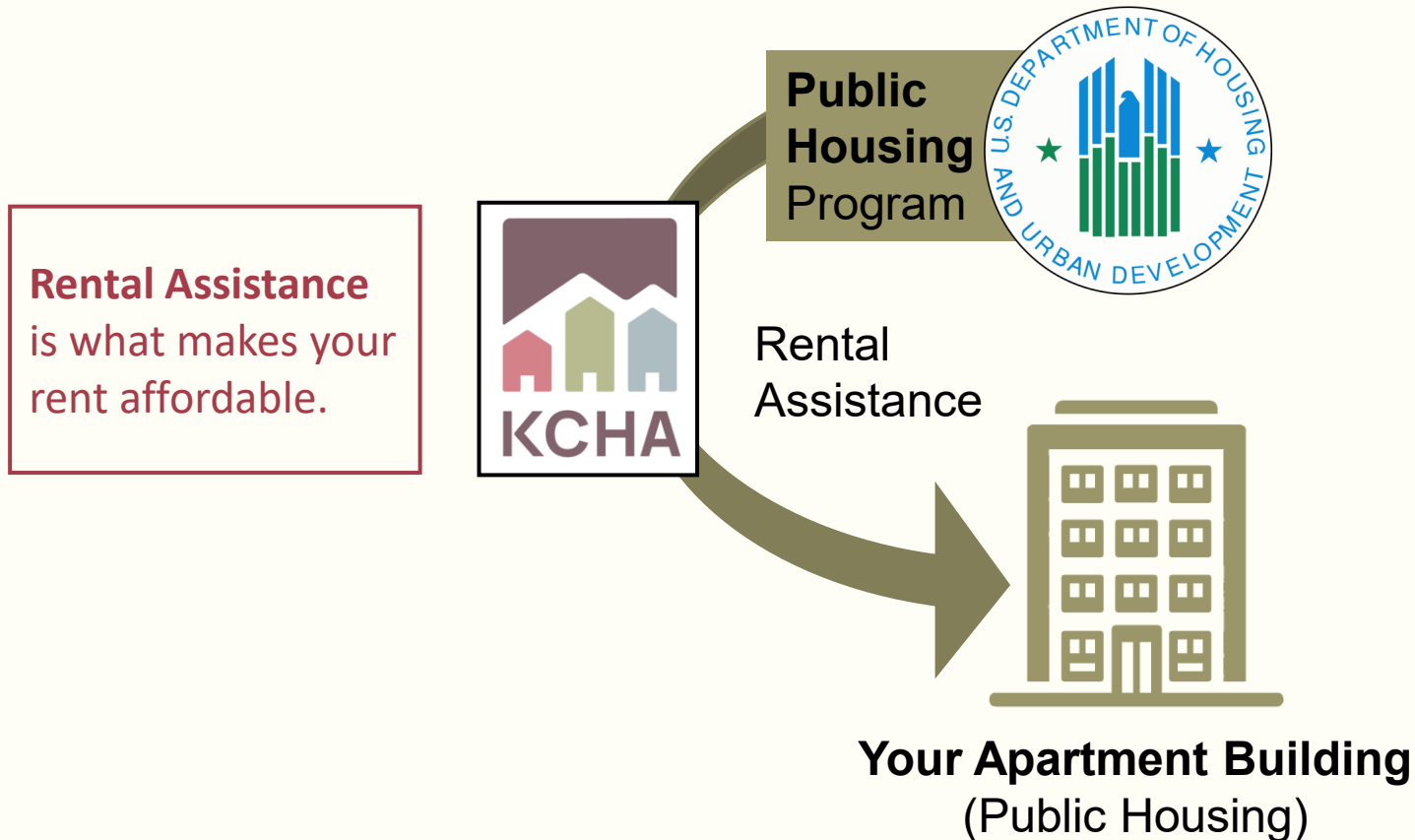

How does **RAD** work?

RAD changes the **source** of rental assistance from **public housing** to **Section 8** project-based vouchers

RAD units remain **permanently** affordable to low-income households.

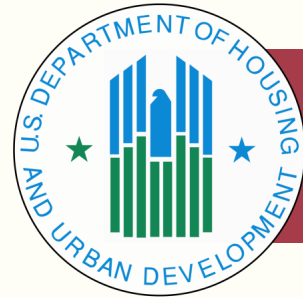

Section 8
Program

Rental
Assistance



- More stable source of funding
- Funding adjusts for local rent and utility changes
- More flexible funding
- Allows KCHA to access other sources of funding



Your Apartment Building
(RAD Project-Based Voucher)

Residents **retain their housing,** affordable rent, and tenant protections.



Most residents' **rent will not change** because of RAD.



Residents keep their **same rights** and resident protections.



After living in a RAD unit for 12 months, residents have the option of requesting a **Tenant-Based Voucher** to relocate anywhere in the country that accepts Section 8 vouchers.





Why convert to the Section 8 program?



Public Housing Funding Has Dropped While Section 8 Funding Has Responded to Cover Rising Needs

Percent change in funding since 2000, adjusted for inflation

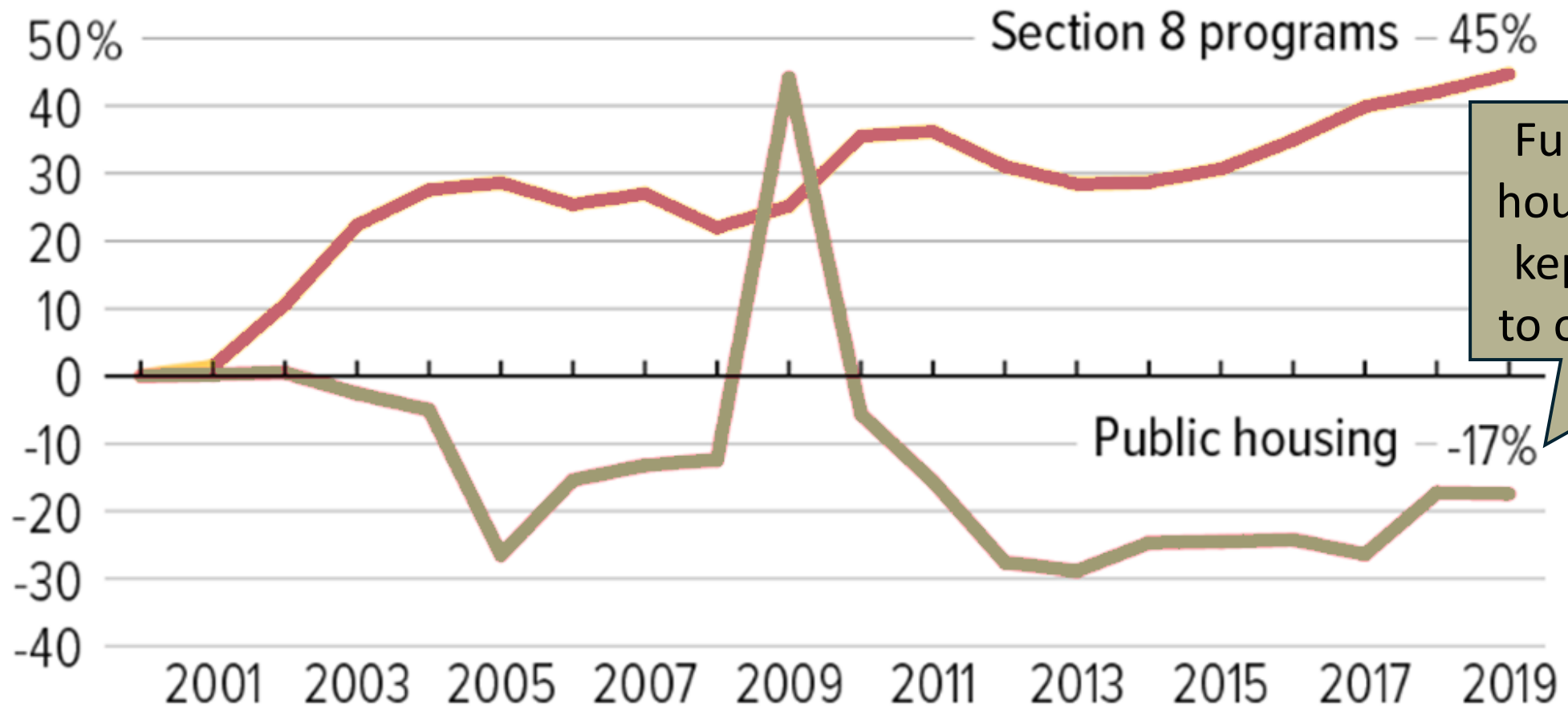

Funding for the public housing program hasn't kept up with the costs to operate the program



Converting to **RAD** means that KCHA can continue to invest in repairs and improvements to your apartment building.



KCHA's Plan For Your Apartment Building



KCHA's plan for your apartment building

Our plan for your apartment building is a “**straight conversion**” also referred to as a “**subsidy only conversion.**”

This means that KCHA is shifting our existing public housing funding for your apartment building to the Section 8 program without taking on new debt or undertaking major renovation or improvements as part of the RAD conversion.

KCHA's plan for your apartment building (continued)

KCHA's plan for your apartment building:

- Will **not** include any major renovations to your property
- Will **not** transfer rental assistance from your property to another
- Will **not** partner with a developer or any other entity
- Will **not** affect your eligibility for rental assistance
- Will **not** require you to **temporarily** move out for your unit

Our final property inspection report doesn't list any repairs that would require temporary relocation!

KCHA's plan for your apartment building (continued)

KCHA's plan for your apartment building:

- Will **not** include any major renovations to your property
- Will **not** transfer rental assistance from your property to another
- Will **not** partner with a developer or any other entity
- Will **not** affect your eligibility for rental assistance
- **May** require you to **temporarily relocate** for KCHA to make required repairs to your unit.

Most residents impacted would only need to relocate for a **few days**.

KCHA's plan (continued)

Our plan is to simply change **your apartment building's** primary source of federal funding from public housing to Section 8 rental assistance through RAD.



RAD Conversion Process & Timeline



RAD Conversion Process



For more information, see HUD's **RAD Fact Sheet #3 – RAD Conversion Process**

URL: https://www.hud.gov/sites/dfiles/Housing/documents/RADResidentFactSheet_3_RADConversionProcess.pdf

RAD Conversion

We first met with you in April

- 1. Resident Meetings - April 2025
- 2. Board Resolution - May 2025
- 3. Submit Application to HUD - June 2025
- 4. HUD Initial Approval (CHAP Award) - August/September 2025
- 5. Property Inspection (identify repair needs) - August 2025
- 6. Resident Meetings - October 2025
- 7. Resident Meeting - March 2026
- 8. Concept Call with HUD
- 9. Financing Plan
- 10. HUD Approval (RAD Conversion Commitment)
- 11. Resident Meetings
- 12. Sign New Lease
- 13. RAD Conversion (Closing)
- 14. Begin Non-Critical Repairs

This is where we are
NOW

RAD Conversion – Next Steps

1. Resident Meetings - April 2025
2. Board Resolution - May 2025
3. Submit Application to HUD - June 2025
4. HUD Initial Approval (CHAP Award) - August/September 2025
5. Property Inspection (identify repair needs) - August 2025
6. Resident Meetings - October 2025
7. Resident Meeting - March 2026
8. Concept Call with HUD ~ *April 2026*
9. Financing Plan ~ *May 2026*
10. HUD Approval (RAD Conversion Commitment) ~ *June 2026*
11. **Resident Meetings** ~ *August 2026*
12. Sign New Lease ~ *August 2026*
13. RAD Conversion (Closing) ~ *September 2026*
14. Begin Non-Critical Repairs ~ *October 2026*

Future dates are **estimated** and likely to change.



What's Next?



What's Next?

1. Critical Repairs (required before RAD Conversion)
2. Official HUD Approval (RAD Conversion Commitment)
3. Residents sign a new lease
4. Conversion (change from Public Housing to RAD Project-Based Section 8)
5. Non-Critical Repairs (required within 12 months of RAD conversion)
6. Resident eligible to request a Tenant-Based Voucher (Choice Mobility Voucher)
– 12 months after RAD Conversion

Critical repairs (before RAD conversion)

- Lower community room kitchen sink and/or cabinets
- Modifications to existing handicapped dwelling units
- Cane detection at the underside of the staircase assemblies
- Modifications to community restrooms to make them more wheelchair accessible
- Seismic straps on water heaters in some units

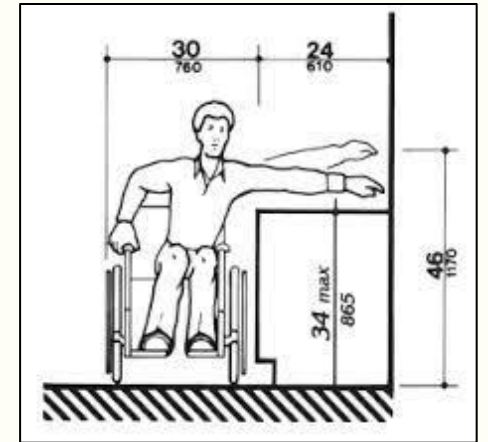

HUD Approval (RAD Conversion Commitment)

This is HUD's approval of KCHA's RAD conversion plan.

KCHA will inform residents about the:

- Timing of the conversion
- Plan for repairs
- Revised terms of the lease and house rules
- If any relocation is expected and when it will begin
- Opportunities to take advantage of the choice-mobility option

New Lease (Public Housing Lease Ends)

As part of the RAD conversion process your public housing lease will end and you will need to sign a new lease.

- The terms of the new lease will be similar to your current lease.
- In addition to your new lease, you will also need to sign a **RAD Lease Addendum**, which will include RAD's resident procedural rights.

For more information, see HUD's **RAD Fact Sheet #7 – Your Lease**

URL: https://www.hud.gov/sites/dfiles/Housing/documents/RADResidentFactSheet_7_YourLease.pdf

RAD Conversion to Section 8 program

The property converts from public housing to Section 8 RAD Project-Based Vouchers (PBV).

- Your public housing lease ends, and your new lease begins.
- You become a participant in the Section 8 program.
- A legal document called a **RAD Use Agreement** is attached to the property, requiring the owner (KCHA) to use the property as affordable housing.

Choice Mobility (tenant-based voucher)

- After living in a RAD unit for a year (**12 months after conversion**) residents may choose to take a Tenant-Based Voucher and relocate anywhere in the country that accepts Section 8 vouchers.

For more information, see HUD's **RAD Fact Sheet #12 – Choice Mobility**

URL: https://www.hud.gov/sites/dfiles/Housing/documents/RADResidentFactSheet_12_ChoiceMobility.pdf



Relocation



Our plans do not require relocation

- The property inspection **didn't** identify any repair needs that would require you to temporarily relocate from your unit.
- If relocation is necessary, KCHA will be required to maintain a resident log for all impacted residents, and provide residents with:
 - Advanced written notice
 - Moving assistance
 - Benefits and assistance per the “Uniform Relocation Assistance and Real Property Acquisition Policies Act (URA)”
- **No resident will be permanently, involuntarily displaced**

For more information, see HUD's **RAD Fact Sheet #9 – RAD and Relocation**

URL: https://www.hud.gov/sites/dfiles/Housing/documents/RADResidentFactSheet_9_RADandRelocation.pdf

Relocation

- Where relocation is necessary, KCHA must provide residents with:
 - Advanced written notice
 - Moving assistance
 - Benefits and assistance per the Uniform Relocation Assistance and Real Property Acquisition Policies Act (URA)
- KCHA will maintain a resident log for all impacted residents
- **No resident will be permanently, involuntarily displaced**

For more information, see HUD's **RAD Fact Sheet #9 – RAD and Relocation**

URL: https://www.hud.gov/sites/dfiles/Housing/documents/RADResidentFactSheet_9_RADandRelocation.pdf



What You Need to Know About RAD



Our **RAD** conversion plan will not change your experience of living at your apartment building

- The rent you pay under RAD will be calculated based on adjusted annual household income, like it is now under the public housing program.
- KCHA will still own your building.
- Your property management and maintenance team will not change.
- You will keep your housing assistance, but the funding source of that assistance will change.
- You won't need to be re-screened and there are no additional eligibility requirements.
- You won't need to temporarily relocate for KCHA to complete required repairs
- You will need to stay in good standing with your current lease.
- You will need to sign a new lease.

Our **RAD** conversion plan will not change your experience of living at your apartment building

- The rent you pay under RAD will be calculated based on adjusted annual household income, like it is now under the public housing program.
- KCHA will still own your building.
- Your property management and maintenance team will not change.
- You will keep your housing assistance, but the funding source of that assistance will change.
- You won't need to be re-screened and there are no additional eligibility requirements.
- You **may** need to temporarily relocate for KCHA to complete required repairs
- You will need to stay in good standing with your current lease.
- You will need to sign a new lease.

What **RAD** means for KCHA

- Resident stability
- Preservation of affordable housing
- More stable and flexible funding
- Choice mobility for residents
- Keeping our building up to date with repairs and improvements

More Information about RAD and KCHA's plans for your property:



- Visit the RAD page on KCHA's website <https://www.kcha.org/residents/radp>
- If you have questions about the changes, contact your **property management office**.
- Email comments about KCHA's plans for RAD at your property, to RAD@kcha.org
- For HUD resources and information about the RAD program, visit: www.hud.gov/rad

We will provide you more information about RAD and future meetings in the coming months.

Questions and Comments

