

# Lake House – RAD Conversion Update

## Rental Assistance Demonstration

*March 12, 2026*

*Presented by:  
Nicole Damm, AVP of Property Management Admin.  
King County Housing Authority*





# RAD Overview



# What is **RAD**?

Rental **Assistance Demonstration (RAD)**

A program created by the U.S. Department of **Housing and Urban Development (HUD)** that gives public housing authorities new flexibility to preserve and improve public housing properties like yours.



# How does **RAD** work?

RAD changes the **source** of rental assistance from **public housing** to **Section 8** project-based vouchers

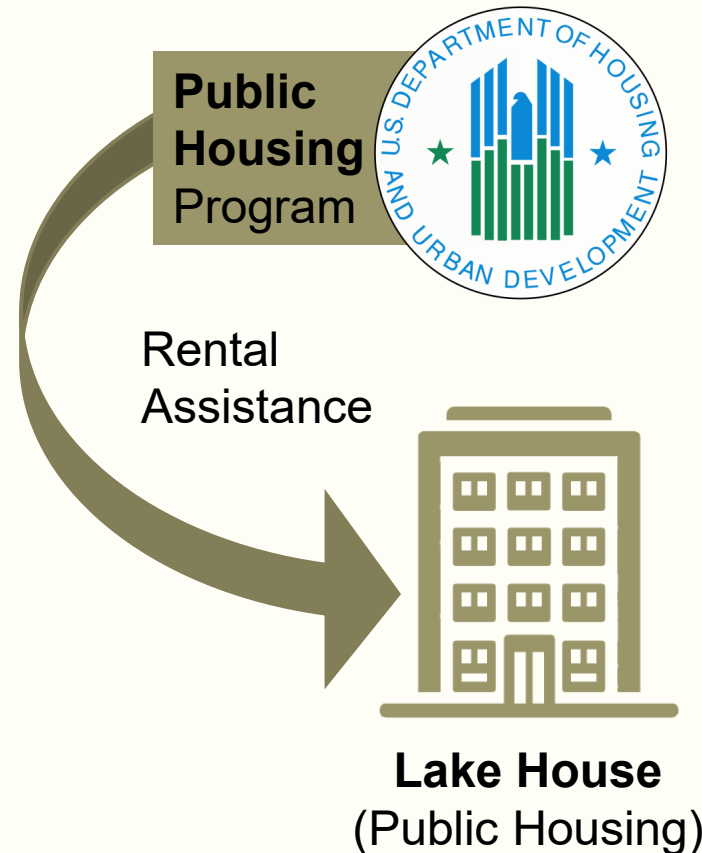

# How does **RAD** work?

RAD changes the **source** of rental assistance from **public housing** to **Section 8** project-based vouchers

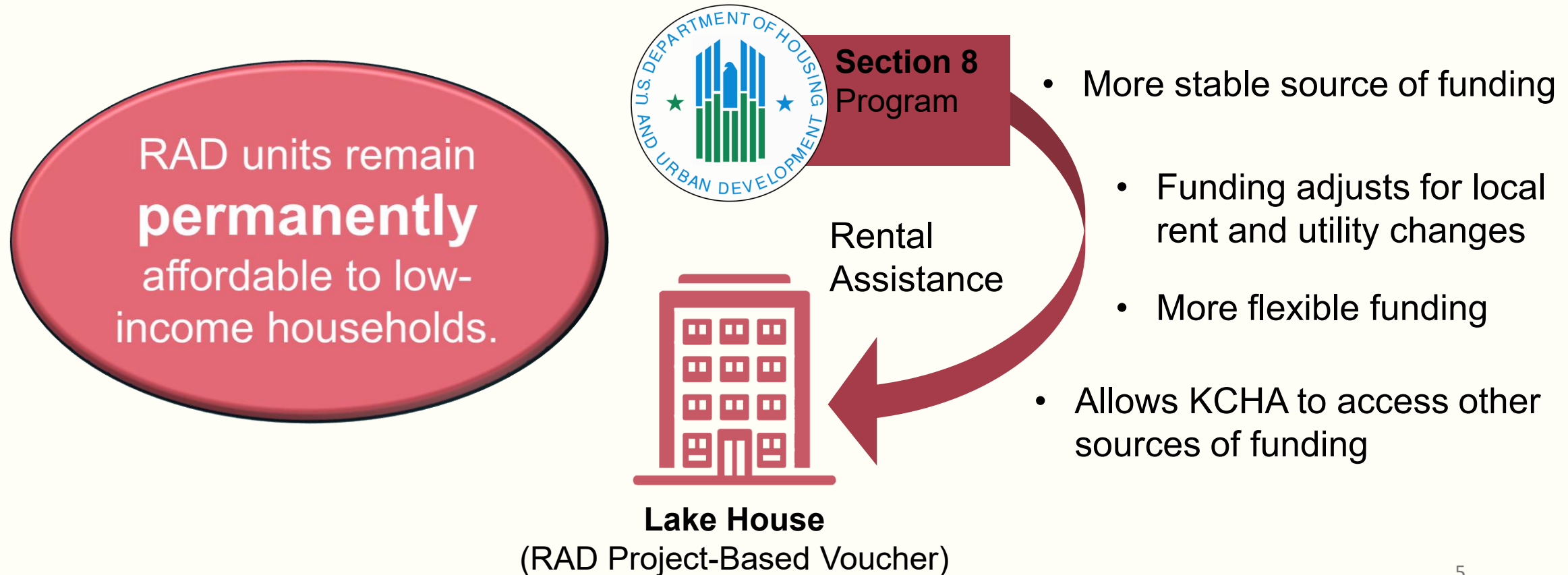



# Why convert to the Section 8 Program?



# Public Housing Funding Has Dropped While Section 8 Funding Has Responded to Cover Rising Needs

Percent change in funding since 2000, adjusted for inflation



Funding for the public housing program hasn't kept up with the costs to operate the program



Converting to **RAD** means that KCHA can continue to invest in repairs and improvements to your apartment building.

Residents **retain their housing,** affordable rent and tenant protections.



Most residents **rent will not change** because of RAD.



Residents keep their **same rights** and resident protections.



After 12 months residents may choose to take a **Tenant-Based Voucher** and relocate anywhere in the country that accepts Section 8 vouchers.





# KCHA's Plan For Lake House



# KCHA's plan for Lake House

Our plan for your apartment building is a “**straight conversion**” also referred to as a “**subsidy only conversion**”.

This means that KCHA is shifting our existing public housing funding for your apartment building to the Section 8 program without taking on new debt or undertaking major renovation or improvements as part of the RAD conversion.

# KCHA's plan for Lake House (continued)

## KCHA's plan for your apartment building:

- Will **not** include any major renovations to your property
- Will **not** transfer rental assistance from your property to another
- Will **not** partner with a developer or any other entity
- Will **not** affect your eligibility for rental assistance
- Will **not** require you to temporarily move out of your unit

Our final property inspection report **doesn't** list any repairs that would require temporary relocation!

# KCHA's plan for Lake House (continued)

Our plan is to simply change **your apartment building's** primary source of federal funding from public housing to Section 8 rental assistance through RAD.



# Lake House RAD Conversion Process & Timeline



# RAD Conversion Process



# RAD Conversion

We first met with you in April

- 1. Resident Meetings - April 2025
- 2. Board Resolution - May 2025
- 3. Submit Application to HUD - June 2025
- 4. HUD Initial Approval (CHAP Award) - September 2025
- 5. Property Inspection (identify repair needs) - August 2025
- 6. Resident Meetings - October 2025
- 7. Resident Meeting - March 2026
- 8. Concept Call with HUD
- 9. Financing Plan
- 10. HUD Approval (RAD Conversion Commitment)
- 11. Resident Meetings
- 12. Sign New Lease
- 13. RAD Conversion (Closing)
- 14. Begin Non-Critical Repairs

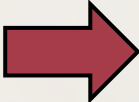

This is where we are  
**NOW**

# RAD Conversion – Next Steps

1. Resident Meetings - April 2025
2. Board Resolution - May 2025
3. Submit Application to HUD - June 2025
4. HUD Initial Approval (CHAP Award) - September 2025
5. Property Inspection (identify repair needs) - August 2025
6. Resident Meetings - October 2025
7. Resident Meeting - March 2026
8. Concept Call with HUD ~ *April 2026*
9. Financing Plan ~ *May 2026*
10. HUD Approval (RAD Conversion Commitment) ~ *June 2026*
11. **Resident Meetings** ~ *August 2026*
12. Sign New Lease ~ *August 2026*
13. RAD Conversion (Closing) ~ *September 2026*
14. Begin Non-Critical Repairs ~ *October 2026*

Future dates are **estimated** and likely to change.



# What's Next?



# Critical Repairs – Before RAD Conversion

- Modifications to accessible parking
- Modifications to the common area restrooms to improve accessibility
- Lower community room kitchen sink and cabinets
- Barriers at the underside of the staircases
- Seismic straps on water heaters

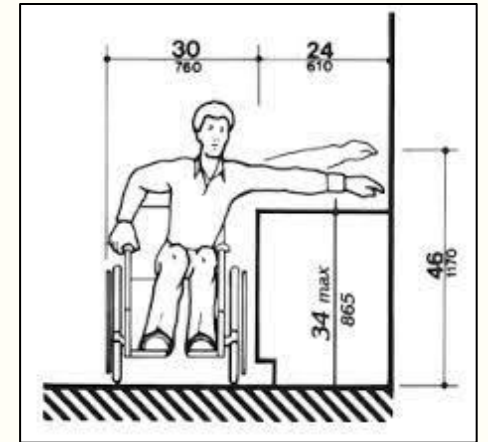

# Resident Meetings

- We will meet with you again after we receive HUD approval to convert to RAD (RAD Conversion Commitment).
- If there are any major changes to our RAD conversion plan, we will meet with you sooner.

# Lease Signing

- Before we convert to RAD you will need to sign a new lease.



# Relocation



# Our plans do not require relocation

- The property inspection **didn't** identify any repair needs that would require you to temporarily relocate from your unit.
- If relocation is necessary, KCHA will be required to maintain a resident log for all impacted residents, and provide residents with:
  - Advanced written notice
  - Moving assistance
  - Benefits and assistance per the “Uniform Relocation Assistance and Real Property Acquisition Policies Act (URA)”
- **No resident will be permanently, involuntarily displaced**

**For HUD Facts about RAD and Relocation, see RAD Fact Sheet #9:**

[www.hud.gov/sites/dfiles/Housing/documents/RADResidentFactSheet\\_9\\_RADandRelocation.pdf](http://www.hud.gov/sites/dfiles/Housing/documents/RADResidentFactSheet_9_RADandRelocation.pdf)



# What You Need to Know About RAD



# Our **RAD** conversion plan will not change your experience of living at your apartment building

- The rent you pay under RAD will be calculated based on adjusted annual household income, like it is now under the public housing program.
- KCHA will still own your building.
- Your property management and maintenance team will not change.
- You will keep your housing assistance, but the funding source of that assistance will change.
- You won't need to be re-screened and there are no additional eligibility requirements.
- You won't need to temporarily relocate for KCHA to complete required repairs
- You will need to stay in good standing with your current lease.
- You will need to sign a new lease.

# What **RAD** means for KCHA

- Resident stability
- Preservation of affordable housing
- More stable and flexible funding
- Choice mobility for residents
- Keeping our building up to date with repairs and improvements

# More Information about RAD and KCHA's plans for your property:



- Visit the RAD page on KCHA's website <https://www.kcha.org/residents/radp>
- If you have questions about the changes, contact your **property management office**.
- Email comments about KCHA's plans for RAD at your property, to [RAD@kcha.org](mailto:RAD@kcha.org)
- For HUD resources and information about the RAD program, visit: [www.hud.gov/rad](http://www.hud.gov/rad)

**We will provide you more information about RAD and future meetings in the coming months.**

# Questions and Comments

