

# **REQUEST FOR BIDS**

## **GREENBRIDGE APT. BUILDINGS A, B & C WALKWAY REPAIRS**

9915 7<sup>TH</sup> AVE.  
SEATTLE, WA 98106

RELEASED BY:



**King County  
Housing  
Authority**

**ASSET MANAGEMENT DEPARTMENT  
600 ANDOVER PARK WEST  
TUKWILA, WA 98188**

### **BID DATES**

**ISSUANCE DATE: APRIL 15, 2026**

**DUE DATE: MAY 27, 2026**

**TIME: 11:00AM**

## **TABLE OF CONTENTS SECTIONS**

- A. INFORMATIONAL FORMS**
- B. BID PROPOSAL**
- BB. NO PARTICIPATION – RESPONSE FORM**
- C. CONTRACT DOCUMENTS**
- D. THIRD PARTY REPORTS**
- E. DRAWINGS AND SPECIFICATIONS**

# **A - SECTION**

## **INFORMATIONAL FORMS**

- A.1 Invitation to Bid**
- A.2 Notice to All Bidders**
- A.3 Instructions to Bidders for Contracts (form HUD 5369)**
- A.4 Fair Housing / Accessibility Notice**
- A.5 Pre-Bid Conference – MANDATORY ATTENDANCE**
- A.6 Project Wage Rates**
- A.7 Tax Applications**
- A.8 Section 3**
  - a. Clause**
  - b. Supplemental Instruction to Bidders**
- A.9 Progress Payment Suspension Criteria**
- A.10 Executive Order 11246 (as Amended)**
- A.11 Compliance with Executive Order 13496**
- A.12 Requirements for Public Works Jobs**
  - a. Requirements for Public Works Jobs**
  - b. Screenshots of Intent**
  - c. Davis Bacon & Related Acts Provisions; Contract Work Hours & Safety Standards Act; General Information**

**INVITATION FOR BID****DUE DATE: MAY 27, 2026**

The King County Housing Authority (KCHA) will accept bids from qualified general contractors to furnish labor, materials and necessary equipment to perform the following:

**SCOPE OF WORK: GREENBRIDGE APT. BUILDINGS A, B & C WALKWAY REPAIRS**

*(Work includes, but is not limited to, structural repairs to elevated walkway at the fully occupied buildings A, B and C. Contract scope includes removing and re-installation of existing metal railings at walkways as needed to perform repairs while ensuring safety measures are in place to maintain resident access. The contractor is to remove soffits and deck sheathing as required to perform structural work on walkways. The contractor is to remove walkway support post and knee braces and replace with steel framing utilizing existing knife plates for connections. Replace walkway edge wood beams.)*

**[For complete scope, please see E.1 Scope of Work and Technical Specifications](#)**

**DRAWINGS – PROJECT MANUAL DISTRIBUTION:**

Drawing and bid documents can be downloaded from:

<https://www.kcha.org/business/construction/open>

**PRE-BID MEETING:**

Date: **May 5, 2026**  
Time: **11:00 AM**  
Jobsite Address: **9915 7<sup>TH</sup> AVE., SEATTLE, WA 98106**  
Notation: Attendance of the Pre-Bid Site Visit is **MANDATORY**.  
Questions / Direct Questions, Requests or Clarification by Email to:  
Contact Person: Contract Manager: Michelle Jackson  
Email Address: michellej@kcha.org  
No Later Than: May 20, 2026, at 9:00 am  
<https://www.kcha.org/business/construction/open>  
Website Posting: All responses shall be in the form of Addenda  
All Addenda(s) will post As Occurs  
Plan Holder's List posts every Friday

**BIDS ARE DUE: May 27, 2026**

Date: **11:00 AM**  
Time: King County Housing Authority  
Address: 600 Andover Park West, Tukwila, WA 98188

**Submittal Procedure: Envelope MUST BE:**

- a. Sealed
- b. List Name and Address of your Firm/Company
- c. List Due Date and Time
- d. List Project Name:

**GREENBRIDGE APT. BUILDINGS A, B & C WALKWAY REPAIRS**

- e. Mailing / Shipping Package or Wrapping **must also be marked** with this information.

KCHA Process: **All Bids MUST BE Time and Date Stamped at King County Housing Authority's Central Campus by the above Due Date and Time.**

- a. **No Bids will be accepted after that Date and Time.**

- b. No Bids Faxed or Emailed will be accepted.
  - c. A KCHA representative will be present at the front desk at **600 Andover Park West, Tukwila, WA 98188** to time stamp bids.
  - d. Bids will be accepted until **11:00 am on the bid due date**.
  - e. At 11:00AM bidding will be closed and no further bids will be accepted.
  - f. Bids received on or before 11:00 AM will be opened and read in the presence of one or more witnesses, which includes KCHA staff (project manager and project specialist). **Bidding Contractors are invited to attend the public opening.**
  - g. Bids will be tabulated and bidders notified by email of the bid results.
- \*\*NOTE:** Contractors have the option to mail in bids, but bids must be received by the deadline of 11:00AM. KCHA does not recommend mailing in bids due to possible complications or difficulties that may arise with the mail delivery.

**BID BOND OR CERTIFIED CHECK:**

Amount: **Five (5%) Percent** of the Total bid must accompany Each Bid **greater than one hundred fifty thousand (\$150,000) dollars.**

Payable to: King County Housing Authority

Process: Bid Bond or Certified Check will be returned to the Unsuccessful Bidders within **Ten (10) Days** after the Contract Award.

**BONDS MUST BE ORIGINAL, NO PHOTOCOPIES OR SCANNED BONDS WILL BE ALLOWED**

**MASKING COMPLIANCE**

Contractor's employees and all sub-contractors' employees will be required to wear a mask if they are asked to do so by a resident or property manager while in a building or a resident's unit.

**ASSURANCE OF COMPLETION:**

Projects valued over one hundred fifty thousand (\$150,000) dollars **require** a one hundred (100%) percent Performance and Payment Bond. (See Section C – Contract Documents)

**BONDING CAPACITY:**

Provide **with your bid proposal**, a written statement from the contractor's bonding agent of the contractor's ability and capacity for providing a one hundred (100%) percent Performance and Payment Bond for the project. The statement shall be made on the official letterhead of the bonding company and signed by an authorized agent of the bonding company.

**BONDING & INSURANCE FOR CONTRACT AWARD:**

The contract award will be contingent on full performance bonding, or equivalent and contractor's ability to meet KCHA insurance requirements as outlined in the bid documents.

**HUD NON-ROUTINE MAINTENANCE WAGE RATES:**

Bidders should note that the current HUD Non-Routine Maintenance wage rates and weekly payroll reporting requirements apply to this project.

**WASHINGTON STATE REQUIREMENT:**

All contractors and subcontractors working on this project are required to file a "Statement of Intent to Pay Prevailing Wages", "Affidavit of Wages Paid" and certified payroll with L&I. (See Form **A.12** for additional information.)

**EEOE:**

The King County Housing Authority is an Equal Employment Opportunity Employer and strongly encourages minority-owned and women-owned businesses, socially and economically



disadvantaged businesses, and small businesses to submit bids or to participate as subcontractors and suppliers on KCHA Contracts.

**KCHA RESERVED RIGHTS:**

The King County Housing Authority reserves the right to reject any or all bids or to waive any informality in the bidding. No bid shall be withdrawn for a period of thirty (30) calendar days subsequent to the opening of the bids without the written consent of KCHA.

The King County Housing Authority also reserves the right to reject all bids, for any reason, prior to Contract Execution.

**PUBLIC RECORDS:**

All information submitted to KCHA will become public records, as per RCW 42.56. If you are submitting information, which you think is confidential and/or proprietary to your business, KCHA recommends that you do not submit that information, as KCHA cannot guarantee that type of information will be withheld from a public disclosure request.

**PLAN CENTERS:**

Bid documents, including drawings, specifications and conditions of the agreements may be examined at the following offices:

BUILDERS EXCHANGE OF WA  
2607 Wetmore Ave.  
Everett, WA 98201  
[www.bxwa.com](http://www.bxwa.com)  
425-258-1303

PLAN CENTER NW  
P.O. Box 2486  
Clackamas, OR 97015  
<https://plancenternw.com/>  
503-650-0148

DAILY JOURNAL OF COMMERCE  
[www.djc.com](http://www.djc.com)  
206-622-8272

DODGE CONSTRUCTION  
NETWORK  
[www.construction.com](http://www.construction.com)  
877-784-9556

ISQFT  
[www.isqft.com](http://www.isqft.com)  
800-364-2059 x7051

The King County Housing Authority is an Equal Employment Opportunity Employer and strongly encourages minority-owned and women-owned businesses, socially and economically disadvantaged businesses, and small businesses to submit bids or to participate as subcontractors and suppliers on KCHA Contracts.

The King County Housing Authority reserves the right to reject any or all bids or to waive any informality in the bidding. No bid shall be withdrawn for a period of thirty (30) calendar days subsequent to the opening of the bids without the written consent of KCHA.

**PUBLICATION:** Daily Journal of Commerce  
El Siete Dias  
Northwest Asian Weekly  
KCHA Web Site [www.kcha.org/business/construction/open](http://www.kcha.org/business/construction/open)

**CONTACT PERSON:**

Antoni Walker Project Manager  
206-940-9781 Phone Number  
antoniw@kcha.org Email Address

**EXAMPLE OF SEALED ENVELOPE PROCEDURE / PREPARATION:**

FROM:	
ENTER YOUR COMPANY NAME	
Street Address	
City, State, Zip Code	
TO:	
KING COUNTY HOUSING AUTHORITY	
ASSET MANAGEMENT DEPARTMENT	
600 Andover Park West	
Tukwila, WA 98188	
BID DUE:	
Date: May 27, 2026	
Time: 11:00 AM	
PROJECT NAME:	GREENBRIDGE APT. BUILDINGS A, B & C WALKWAY REPAIRS

**Upon Receipt, the Envelope will be Time and Date Stamped by  
King County Housing Authority**



## NOTICE TO ALL BIDDERS

In order to be considered as **RESPONSIVE BIDS**, all bidders **MUST** submit Signed Section B forms no later than the **Bid Due Date and Time**:

- B.1 Bid Form**
- B.2 Bidder's Experience Record**
- B.3 Contractor Certification**
- B.4 Non-Collusive Affidavit**
- B.5 Equal Opportunity**
- B.6 Bid Security (Submit only for bids greater than \$150,000)**
- B.7 Debarment / Suspension Compliance Certification**
- B.8 Proposed Subcontractor List**
- B.9 Section 3**
  - a. Business Certification**
  - b. Subcontractor Work Plan**
- B.10 Harassment and Discrimination Policies**
- B.11 WMBE Survey (Form is not required to be responsive, but requested)**
- B.12 Preliminary Project Schedule – Provided by Contractor**

**FORM 5369**

**From HUD Website 2021**

**U.S. Department of Housing and  
Urban Development**  
Office of Public and Indian Housing

**Instructions to Bidders for Contracts  
Public and Indian Housing Programs**

# Instructions to Bidders for Contracts

## Public and Indian Housing Programs

### Table of Contents

Clause	Page
1. Bid Preparation and Submission	1
2. Explanations and Interpretations to Prospective Bidders	1
3. Amendments to Invitations for Bids	1
4. Responsibility of Prospective Contractor	1
5. Late Submissions, Modifications, and Withdrawal of Bids	1
6. Bid Opening	2
7. Service of Protest	2
8. Contract Award	2
9. Bid Guarantee	3
10. Assurance of Completion	3
11. Preconstruction Conference	3
<del>12. Indian Preference Requirements</del>	<del>3</del>

### 1. Bid Preparation and Submission

(a) Bidders are expected to examine the specifications, drawings, all instructions, and, if applicable, the construction site (see also the contract clause entitled **Site Investigation and Conditions Affecting the Work** of the *General Conditions of the Contract for Construction*). Failure to do so will be at the bidders' risk.

(b) All bids must be submitted on the forms provided by the Public Housing Agency/Indian Housing Authority (PHA/IHA). Bidders shall furnish all the information required by the solicitation. Bids must be signed and the bidder's name typed or printed on the bid sheet and each continuation sheet which requires the entry of information by the bidder. Erasures or other changes must be initialed by the person signing the bid. Bids signed by an agent shall be accompanied by evidence of that agent's authority. (Bidders should retain a copy of their bid for their records.)

(c) ~~Bidders must submit as part of their bid a completed form HUD-5369-A, "Representations, Certifications, and Other Statements of Bidders."~~

(d) All bid documents shall be sealed in an envelope which shall be clearly marked with the words "Bid Documents," the Invitation for Bids (IFB) number, any project or other identifying number, the bidder's name, and the date and time for receipt of bids.

(e) If this solicitation requires bidding on all items, failure to do so will disqualify the bid. If bidding on all items is not required, bidders should insert the words "No Bid" in the space provided for any item on which no price is submitted.

(f) Unless expressly authorized elsewhere in this solicitation, alternate bids will not be considered.

(g) Unless expressly authorized elsewhere in this solicitation, bids submitted by telegraph or facsimile (fax) machines will not be considered.

(h) If the proposed contract is for a Mutual Help project (as described in 24 CFR Part 905, Subpart E) that involves Mutual Help contributions of work, material, or equipment, supplemental information regarding the bid advertisement is provided as an attachment to this solicitation.

HUD 5369-A is covered by other forms within this project Bid Document. See last page for listing.

### 2. Explanations and Interpretations to Prospective Bidders

(a) Any prospective bidder desiring an explanation or interpretation of the solicitation, specifications, drawings, etc., must request it at least 7 days before the scheduled time for bid opening. Requests may be oral or written. Oral requests must be confirmed in writing. The only oral clarifications that will be provided will be those clearly related to solicitation procedures, i.e., not substantive technical information. No other oral explanation or interpretation will be provided. Any information given a prospective bidder concerning this solicitation will be furnished promptly to all other prospective bidders as a written amendment to the solicitation, if that information is necessary in submitting bids, or if the lack of it would be prejudicial to other prospective bidders.

(b) Any information obtained by, or provided to, a bidder other than by formal amendment to the solicitation shall not constitute a change to the solicitation.

### 3. Amendments to Invitations for Bids

(a) If this solicitation is amended, then all terms and conditions which are not modified remain unchanged.

(b) Bidders shall acknowledge receipt of any amendment to this solicitation (1) by signing and returning the amendment, (2) by identifying the amendment number and date on the bid form, or (3) by letter, telegram, or facsimile, if those methods are authorized in the solicitation. The PHA/IHA must receive acknowledgement by the time and at the place specified for receipt of bids. Bids which fail to acknowledge the bidder's receipt of any amendment will result in the rejection of the bid if the amendment(s) contained information which substantively changed the PHA's/IHA's requirements.

(c) Amendments will be on file in the offices of the PHA/IHA and the Architect at least 7 days before bid opening.

### 4. Responsibility of Prospective Contractor

(a) The PHA/IHA will award contracts only to responsible prospective contractors who have the ability to perform successfully under the terms and conditions of the proposed contract. In determining the responsibility of a bidder, the PHA/IHA will consider such matters as the bidder's:

- (1) Integrity;
- (2) Compliance with public policy;
- (3) Record of past performance; and
- (4) Financial and technical resources (including construction and technical equipment).

(b) Before a bid is considered for award, the bidder may be requested by the PHA/IHA to submit a statement or other documentation regarding any of the items in paragraph (a) above. Failure by the bidder to provide such additional information shall render the bidder nonresponsible and ineligible for award.

**5. Late Submissions, Modifications, and Withdrawal of Bids**

(a) Any bid received at the place designated in the solicitation after the exact time specified for receipt will not be considered unless it is received before award is made and it:

(1) Was sent by registered or certified mail not later than the fifth calendar day before the date specified for receipt of offers (e.g., an offer submitted in response to a solicitation requiring receipt of offers by the 20th of the month must have been mailed by the 15th);

(2) Was sent by mail, or if authorized by the solicitation, was sent by telegram or via facsimile, and it is determined by the PHA/IHA that the late receipt was due solely to mishandling by the PHA/IHA after receipt at the PHA/IHA; or

(3) Was sent by U.S. Postal Service Express Mail Next Day Service - Post Office to Addressee, not later than 5:00 p.m. at the place of mailing two working days prior to the date specified for receipt of proposals. The term "working days" excludes weekends and observed holidays.

(b) Any modification or withdrawal of a bid is subject to the same conditions as in paragraph (a) of this provision.

(c) The only acceptable evidence to establish the date of mailing of a late bid, modification, or withdrawal sent either by registered or certified mail is the U.S. or Canadian Postal Service postmark both on the envelope or wrapper and on the original receipt from the U.S. or Canadian Postal Service. Both postmarks must show a legible date or the bid, modification, or withdrawal shall be processed as if mailed late. "Postmark" means a printed, stamped, or otherwise placed impression (exclusive of a postage meter machine impression) that is readily identifiable without further action as having been supplied and affixed by employees of the U.S. or Canadian Postal Service on the date of mailing. Therefore, bidders should request the postal clerk to place a hand cancellation bull's-eye postmark on both the receipt and the envelope or wrapper.

(d) The only acceptable evidence to establish the time of receipt at the PHA/IHA is the time/date stamp of PHA/IHA on the proposal wrapper or other documentary evidence of receipt maintained by the PHA/IHA.

(e) The only acceptable evidence to establish the date of mailing of a late bid, modification, or withdrawal sent by Express Mail Next Day Service-Post Office to Addressee is the date entered by the post office receiving clerk on the "Express Mail Next Day Service-Post Office to Addressee" label and the postmark on both the envelope or wrapper and on the original receipt from the U.S. Postal Service. "Postmark" has the same meaning as defined in paragraph (c) of this provision, excluding postmarks of the Canadian Postal Service. Therefore, bidders should request the postal clerk to place a legible hand cancellation bull's eye postmark on both the receipt and Failure by a bidder to acknowledge receipt of the envelope or wrapper.

(f) Notwithstanding paragraph (a) of this provision, a late modification of an otherwise successful bid that makes its terms more favorable to the PHA/IHA will be considered at any time it is received and may be accepted.

(g) Bids may be withdrawn by written notice, or if authorized by this solicitation, by telegram (including mailgram) or facsimile machine transmission received at any time before the exact time set for opening of bids; provided that written confirmation of telegraphic or facsimile withdrawals over the signature of the bidder is mailed and postmarked prior to the specified bid opening time. A bid may be withdrawn in person by a bidder or its authorized representative if, before the exact time set for opening of bids, the identity of the person requesting withdrawal is established and the person signs a receipt for the bid.

**Informational Form A.3****6. Bid Opening**

All bids received by the date and time of receipt specified in the solicitation will be publicly opened and read. The time and place of opening will be as specified in the solicitation. Bidders and other interested persons may be present.

**7. Service of Protest**

(a) Definitions. As used in this provision:

"Interested party" means an actual or prospective bidder whose direct economic interest would be affected by the award of the contract.

"Protest" means a written objection by an interested party to this solicitation or to a proposed or actual award of a contract pursuant to this solicitation.

(b) Protests shall be served on the Contracting Officer by obtaining written and dated acknowledgement from —

Contracting Officer  
Asset Management Department  
King County Housing Authority  
600 Andover Park West  
Tukwila, WA 98188

[Contracting Officer designate the official or location where a protest may be served on the Contracting Officer]

(c) All protests shall be resolved in accordance with the PHA's/IHA's protest policy and procedures, copies of which are maintained at the PHA/IHA.

**8. Contract Award**

(a) The PHA/IHA will evaluate bids in response to this solicitation without discussions and will award a contract to the responsible bidder whose bid, conforming to the solicitation, will be most advantageous to the PHA/IHA considering only price and any price-related factors specified in the solicitation.

(b) If the apparent low bid received in response to this solicitation exceeds the PHA's/IHA's available funding for the proposed contract work, the PHA/IHA may either accept separately priced items (see 8(e) below) or use the following procedure to determine contract award. The PHA/IHA shall apply in turn to each bid (proceeding in order from the apparent low bid to the high bid) each of the separately priced bid deductible items, if any, in their priority order set forth in this solicitation. If upon the application of the first deductible item to all initial bids, a new low bid is within the PHA's/IHA's available funding, then award shall be made to that bidder. If no bid is within the available funding amount, then the PHA/IHA shall apply the second deductible item. The PHA/IHA shall continue this process until an evaluated low bid, if any, is within the PHA's/IHA's available funding. If upon the application of all deductibles, no bid is within the PHA's/IHA's available funding, or if the solicitation does not request separately priced deductibles, the PHA/IHA shall follow its written policy and procedures in making any award under this solicitation.

(c) In the case of tie low bids, award shall be made in accordance with the PHA's/IHA's written policy and procedures.

(d) The PHA/IHA may reject any and all bids, except other than the lowest bid (e.g., the apparent low bid is unreasonably low), and waive informalities or minor irregularities in bids received, in accordance with the PHA's/IHA's written policy and procedures.

(e) Unless precluded elsewhere in the solicitation, the PHA/IHA may accept any item or combination of items bid.

(f) The PHA/IHA may reject any bid as nonresponsive if it is materially unbalanced as to the prices for the various items of work to be performed. A bid is materially unbalanced when it is based on prices significantly less than cost for some work and prices which are significantly overstated for other work.

(g) A written award shall be furnished to the successful bidder within the period for acceptance specified in the bid and shall result in a binding contract without further action by either party.

**9. Bid Guarantee** ~~(applicable to construction and equipment contracts exceeding \$25,000)~~

**KCHA Procurement Policy requires Bid Guarantees for Projects valued at \$150,000 or more.**

All bids must be accompanied by a negotiable bid guarantee which shall not be less than five percent (5%) of the amount of the bid. The bid guarantee may be a certified check, bank draft, U.S. Government Bonds at par value, or a bid bond secured by a surety company acceptable to the U.S. Government and authorized to do business in the state where the work is to be performed. In the case where the work under the contract will be performed on an Indian reservation area, the bid guarantee may also be an irrevocable Letter of Credit (see provision 10, Assurance of Completion, below). Certified checks and bank drafts must be made payable to the order of the PHA/IHA. The bid guarantee shall insure the execution of the contract and the furnishing of a method of assurance of completion by the successful bidder as required by the solicitation. Failure to submit a bid guarantee with the bid shall result in the rejection of the bid. Bid guarantees submitted by unsuccessful bidders will be returned as soon as practicable after bid opening.

**10. Assurance of Completion**

(a) Unless otherwise provided in State law, the successful bidder shall furnish an assurance of completion prior to the execution of any contract under this solicitation. This assurance may be [Contracting Officer check applicable items] —

(1) a performance and payment bond in a penal sum of 100 percent of the contract price; or, as may be required or permitted by State law;

(2) separate performance and payment bonds, each for 50 percent or more of the contract price;

(3) a 20 percent cash escrow;

(4) a 25 percent irrevocable letter of credit; or,

(5) an irrevocable letter of credit for 10 percent of the total contract price with a monitoring and disbursements agreement with the IHA (applicable only to contracts awarded by an IHA under the Indian Housing Program).

(b) Bonds must be obtained from guarantee or surety companies acceptable to the U.S. Government and authorized to do business in the state where the work is to be performed. Individual sureties will not be considered. U.S. Treasury Circular Number 570, published annually in the Federal Register, lists companies approved to act as sureties on bonds securing Government contracts, the maximum underwriting limits on each contract bonded, and the States in which the company is licensed to do business. Use of companies listed in this circular is mandatory. Copies of the circular may be downloaded on the U.S. Department of Treasury website <http://www.fms.treas.gov/c570/index.html>, or ordered for a minimum fee by contacting the Government Printing Office at (202) 512-2168.

Treasury website: <https://www.fiscal.treasury.gov/surety-bonds/>

(c) Each bond shall clearly state the rate of premium and the total amount of premium charged. The current power of attorney for the person who signs for the surety company must be attached to the bond. The effective date of the power of attorney shall not precede the date of the bond. The effective date of the bond shall be on or after the execution date of the contract.

(d) Failure by the successful bidder to obtain the required assurance of completion within the time specified, or within such extended period as the PHA/IHA may grant based upon reasons determined adequate by the PHA/IHA, shall render the bidder ineligible for award. The PHA/IHA may then either award the contract to the next lowest responsible bidder or solicit new bids. The PHA/IHA may retain the ineligible bidder's bid guarantee.

**11. Preconstruction Conference** (applicable to construction contracts)

After award of a contract under this solicitation and prior to the start of work, the successful bidder will be required to attend a preconstruction conference with representatives of the PHA/IHA and its architect/engineer, and other interested parties convened by the PHA/IHA. The conference will serve to acquaint the participants with the general plan of the construction operation and all other requirements of the contract (e.g., Equal Employment Opportunity, Labor Standards). The PHA/IHA will provide the successful bidder with the date, time, and place of the conference.

**12. Indian Preference Requirements** ~~(applicable only if this solicitation is for a contract to be performed on a project for an Indian Housing Authority)~~

~~(a) HUD has determined that the contract awarded under this solicitation is subject to the requirements of section 7(b) of the Indian Self-Determination and Education Assistance Act (25 U.S.C. 450e(b)). Section 7(b) requires that any contract or subcontract entered into for the benefit of Indians shall require that, to the greatest extent feasible~~

~~(1) Preferences and opportunities for training and employment (other than core crew positions; see paragraph (h) below) in connection with the administration of such contracts or subcontracts be given to qualified "Indians." The Act defines "Indians" to mean persons who are members of an Indian tribe and defines "Indian tribe" to mean any Indian tribe, band, nation, or other organized group or community, including any Alaska Native village or regional or village corporation as defined in or established pursuant to the Alaska Native Claims Settlement Act, which is recognized as eligible for the special programs and services provided by the United States to Indians because of their status as Indians; and,~~

~~(2) Preference in the award of contracts or subcontracts in connection with the administration of contracts be given to Indian organizations and to Indian-owned economic enterprises, as defined in section 3 of the Indian Financing Act of 1974 (25 U.S.C. 1452). That Act defines "economic enterprise" to mean any Indian-owned commercial, industrial, or business activity established or organized for the purpose of profit, except that the Indian ownership must constitute not less than 51 percent of the enterprise; "Indian organization" to mean the governing body of any Indian tribe or entity established or recognized by such governing body; "Indian" to mean any person who is a member of any tribe, band, group, pueblo, or community which is recognized by the Federal Government as eligible for services from the Bureau of Indian Affairs and any "Native" as defined in the Alaska Native Claims Settlement Act; and Indian "tribe" to mean any Indian tribe, band, group, pueblo, or community including Native villages and Native groups (including~~

~~corporations organized by Kenai, Juneau, Sitka, and Kodiak) as defined in the Alaska Native Claims Settlement Act, which is recognized by the Federal Government as eligible for services from the Bureau of Indian Affairs.~~

~~(b) (1) The successful Contractor under this solicitation shall comply with the requirements of this provision in awarding all subcontracts under the contract and in providing training and employment opportunities.~~

~~(2) A finding by the IHA that the contractor, either (i) awarded a subcontract without using the procedure required by the IHA, (ii) falsely represented that subcontracts would be awarded to Indian enterprises or organizations; or, (iii) failed to comply with the contractor's employment and training preference bid statement shall be grounds for termination of the contract or for the assessment of penalties or other remedies.~~

~~(c) If specified elsewhere in this solicitation, the IHA may restrict the solicitation to qualified Indian-owned enterprises and Indian organizations. If two or more (or a greater number as specified elsewhere in the solicitation) qualified Indian-owned enterprises or organizations submit responsive bids, award shall be made to the qualified enterprise or organization with the lowest responsive bid. If fewer than the minimum required number of qualified Indian-owned enterprises or organizations submit responsive bids, the IHA shall reject all bids and readvertise the solicitation in accordance with paragraph (d) below.~~

~~(d) If the IHA prefers not to restrict the solicitation as described in paragraph (c) above, or if after having restricted a solicitation an insufficient number of qualified Indian enterprises or organizations submit bids, the IHA may advertise for bids from non-Indian as well as Indian-owned enterprises and Indian organizations. Award shall be made to the qualified Indian enterprise or organization with the lowest responsive bid if that bid is-~~

~~(1) Within the maximum HUD approved budget amount established for the specific project or activity for which bids are being solicited; and~~

~~(2) No more than the percentage specified in 24 CFR 905.175(c) higher than the total bid price of the lowest responsive bid from any qualified bidder. If no responsive bid by a qualified Indian-owned economic enterprise or organization is within the stated range of the total bid price of the lowest responsive bid from any qualified enterprise, award shall be made to the bidder with the lowest bid.~~

~~(e) Bidders seeking to qualify for preference in contracting or subcontracting shall submit proof of Indian ownership with their bids. Proof of Indian ownership shall include but not be limited to:~~

~~(1) Certification by a tribe or other evidence that the bidder is an Indian. The IHA shall accept the certification of a tribe that an individual is a member.~~

~~(2) Evidence such as stock ownership, structure, management, control, financing and salary or profit sharing arrangements of the enterprise.~~

~~(f) (1) All bidders must submit with their bids a statement describing how they will provide Indian preference in the award of subcontracts. The specific requirements of that statement and the factors to be used by the IHA in determining the statement's adequacy are included as an attachment to this solicitation. Any bid that fails to include the required statement shall be rejected as nonresponsive. The IHA may require that comparable statements be provided by subcontractors to the successful Contractor, and may require the Contractor to reject any bid or proposal by a subcontractor that fails to include the statement.~~

~~(2) Bidders and prospective subcontractors shall submit a certification (supported by credible evidence) to the IHA in any instance where the bidder or subcontractor believes it is infeasible to provide Indian preference in subcontracting. The acceptance or rejection by the IHA of the certification shall be final. Rejection shall disqualify the bid from further consideration.~~

~~(g) All bidders must submit with their bids a statement detailing their employment and training opportunities and their plans to provide preference to Indians in implementing the contract; and the number or percentage of Indians anticipated to be employed and trained. Comparable statements from all proposed subcontractors must be submitted. The criteria to be used by the IHA in determining the statement(s)'s adequacy are included as an attachment to this solicitation. Any bid that fails to include the required statement(s), or that includes a statement that does not meet minimum standards required by the IHA shall be rejected as nonresponsive.~~

~~(h) Core crew employees. A core crew employee is an individual who is a bona fide employee of the contractor at the time the bid is submitted; or an individual who was not employed by the bidder at the time the bid was submitted, but who is regularly employed by the bidder in a supervisory or other key skilled position when work is available. Bidders shall submit with their bids a list of all core crew employees.~~

~~(i) Preference in contracting, subcontracting, employment, and training shall apply not only on-site, on the reservation, or within the IHA's jurisdiction, but also to contracts with firms that operate outside these areas (e.g., employment in modular or manufactured housing construction facilities).~~

~~(j) Bidders should contact the IHA to determine if any additional local preference requirements are applicable to this solicitation.~~

~~(k) The IHA [ ] does [ ] does not [Contracting Officer check applicable box] maintain lists of Indian-owned economic enterprises and Indian organizations by specialty (e.g., plumbing, electrical, foundations), which are available to bidders to assist them in meeting their responsibility to provide preference in connection with the administration of contracts and subcontracts.~~

The following documents cover all sections in HUD form HUD-5369-A:

- Bid Form (Return Form B.1)
- Contractor Certification (Return Form B.3)
- Non-Collusive Affidavit (Return Form B.4)
- Equal Opportunity Form (Return Form B.5)
- WMBE (Return Form B.11)
- Certification of Payments to Influence Federal Transactions (Contract Form C.7)
- Disclosure of Lobbying Activities (Contract Form C.8)

## FAIR HOUSING/ACCESSIBILITY NOTICE

**A. SUBJECT:**

Accessibility Notice: Section 504 of the Rehabilitation Act of 1973; the Americans with Disabilities Act of 1990; the Architectural Barriers Act of 1968 and the Fair Housing Act of 1988.

**B. PURPOSE:**

The purpose of this Notice is to remind recipients of Federal funds (in this instance, the Public Housing Authority) of their obligation to comply with pertinent laws and implementing regulations which provide for non-discrimination and accessibility in Federally funded housing and non-housing programs for people with disabilities.

**C. NOTIFICATIONS:**

Public housing agencies (PHAs) and other recipients of Federal PIH funds are responsible for providing this Notice to all current and future contractors participating in covered programs / activities or performing work covered under the above subject legislation and implementing regulations.

**D. TO READ THE FULL TEXT OF THE NOTICE:**

Go to [www.kcha.org/business/requirements](http://www.kcha.org/business/requirements)

Scroll down to Fair Housing Laws and Read: **Fair Housing / Accessibility Notice**

## PRE-BID CONFERENCE

There will be a Pre-Bid Conference prior to the date of the bid opening for the purpose of providing a general discussion and review of any questions that might pertain to the bidding documents and procedures. All interested contractors are required to attend this meeting after reading the Project Manual. Please bring Project Manual and drawings, if any, to this conference. ATTENDANCE OF THE PRE-BID CONFERENCE IS REQUIRED FOR ACCEPTANCE OF BID FROM THE CONTRACTOR.

**PROJECT SITE ADDRESS:** GREENBRIDGE/SALMON CREEK  
9915 7<sup>TH</sup> AVE. Seattle, WA. 98106

**CONFERENCE DATE:** May 5, 2026

**TIME:** 11:00 AM

**CONTACT NAME:** Antoni Walker

**EMAIL:** [antoniw@kcha.org](mailto:antoniw@kcha.org)

## PROJECT WAGE RATES

### A. DAVIS BACON WAGE RATES (NA)

### B. HUD NON-ROUTINE MAINTENANCE WAGES

**TYPE OF WAGE RATES:** HUD NON-ROUTINE MAINTENANCE

**WAGE DATE:** 02-01-23

For contracts entered into pursuant to competitive bidding procedures, the bid opening date “locks-in” the Non-Routine Maintenance Wage Rates that will be used during the course of the project.

**NOTE:** The awarded bidder will be required to submit, along with other contractual documentation, Form C.9 Certification of Compliance with Washington State Wage Payment Statutes.

<b>Maintenance Wage Rate Determination</b>	<b>U.S. Department of Housing and Urban Development Office of Labor Relations</b>	
--	---	--

Agency Name: <b>King County Housing Authority</b> <b>600 Andover Park W.</b> <b>Tukwila, WA 98188</b>  <b>(Sedro Woolley, King County HA)</b>	LR 2000 Agency ID No: <b>WA23-ALL</b>  Effective Date: <b>February 1, 2023</b>	Wage Decision Type: <input type="checkbox"/> Routine Maintenance <input checked="" type="checkbox"/> Nonroutine Maintenance  Expiration Date: <b>October 31, 2026</b>
--	--	--

The following wage rate determination is made pursuant to Section 12(a) of the U.S. Housing Act of 1937, as amended, (public housing agencies), or pursuant to Section 104(b) of the Native American Housing Assistance and Self-determination Act of 1996, as amended, (Indian housing agencies). The agency and its contractors may pay to maintenance laborers and mechanics no less than the wage rate(s) indicated for the type of work they actually perform.

<b>Melanie Hertel</b>	<b>revised 11/24/2025</b>
HUD Labor Relations (Name, Title, Signature)	Date

WORK CLASSIFICATION(S)	HOURLY WAGE RATES	
	BASIC WAGE	FRINGE BENEFIT(S) (if any)
Asphalt Painter	\$23.57	\$6.30
Asphalt Raker	\$23.57	\$6.30
Asphalt Roller/Cement Mixer over 16yds.	\$32.24	\$10.49
Backhoe Operator	\$30.52	\$8.85
Carpenter	\$32.24	\$10.49
Cement Mason - Finisher	\$32.24	\$10.49
Concrete Saw Operator	\$30.52	\$8.85
Drywall	\$30.52	\$8.85
Electrician	\$32.24	\$10.49
Elevator Mechanic	\$56.22	\$39.76
Fence Erector	\$23.57	\$6.30
Glazier	\$30.52	\$8.85
HVAC/Furnace Mechanic	\$32.24	\$10.49
Insulation/Pipe Insulator	\$28.18	\$2.02
Ironworker	\$46.76	\$31.00
Laborer	\$30.10	\$8.27
Low Voltage Technician	\$32.24	\$10.49
Motor Grader	\$30.52	\$8.85
Nozzleman for Cement Mixer	\$30.52	\$8.85

The agency employee benefit program has been determined by HUD to be acceptable for meeting the prevailing fringe benefit requirements.  
(HUD Labor Relations: If applicable, check box and initial below.)  
  
 \_\_\_\_\_  
 LR Staff Initial

	<b>FOR HUD USE ONLY</b> <b>LR2000:</b>  <b>Log in:</b>  <b>Log Out:</b>
--	--

<b>Maintenance Wage Rate Determination</b>	<b>U.S. Department of Housing and Urban Development Office of Labor Relations</b>	
Agency Name: <b>King County Housing Authority 600 Andover Park W. Tukwila, WA 98188  (Sedro Woolley, King County HA)</b>	LR 2000 Agency ID No: <b>WA23-ALL</b>	Wage Decision Type: <input type="checkbox"/> Routine Maintenance <input checked="" type="checkbox"/> Nonroutine Maintenance
	Effective Date: <b>February 1, 2023</b>	Expiration Date: <b>October 31, 2026</b>
The following wage rate determination is made pursuant to Section 12(a) of the U.S. Housing Act of 1937, as amended, (public housing agencies), or pursuant to Section 104(b) of the Native American Housing Assistance and Self-determination Act of 1996, as amended, (Indian housing agencies). The agency and its contractors may pay to maintenance laborers and mechanics no less than the wage rate(s) indicated for the type of work they actually perform.		
<u>/s/ Melanie Hertel</u> HUD Labor Relations (Name, Title, Signature)		<u>Revised 11.24.2025</u> Date
<b>WORK CLASSIFICATION(S)</b>	<b>HOURLY WAGE RATES</b>	
	<b>BASIC WAGE</b>	<b>FRINGE BENEFIT(S) (if any)</b>
Painter	\$30.52	\$8.85
Paver/Roller/(Sakai Roller)	\$32.24	\$10.49
Paving Machine Operator – Self Propelled	\$30.52	\$8.85
Pipefitter	\$23.57	\$6.30
Pipe Reliner	\$32.24	\$10.49
Plumber	\$32.24	\$10.49
Pressure Washer	\$23.57	\$6.30
Refrigeration Mechanic	\$32.24	\$10.49
Roofer	\$30.52	\$8.85
Roto-mill/Roto-grinder Operator	\$30.52	\$8.85
Screedman	\$30.52	\$8.85
Sheet Metal Worker	\$32.24	\$10.49
Soft Floor Layer	\$30.52	\$8.85
Sprinkler Fitter (Fire Sprinklers – Class 1 & 2)	\$25.17	\$11.89
Sweeper / Broom Equipment Operator	\$30.52	\$8.85
Tree Trimmer/Tree Climber	\$23.57	\$6.30
Truck Driver – All Yardage	\$30.52	\$8.85
Welder	\$56.68	\$28.02
		<input type="checkbox"/> The agency employee benefit program has been determined by HUD to be acceptable for meeting the prevailing fringe benefit requirements.  <small>(HUD Labor Relations: If applicable, check box and initial below.)</small>  _____ LR Staff Initial
		<b>FOR HUD USE ONLY LR2000:</b>  <b>Log in:</b>  <b>Log Out:</b>

## TAX APPLICATIONS

### TAX APPLICATIONS

If you have questions regarding the application of the retail sales tax exemption to the King County Housing Authority, please call your personal tax advisor or the Washington State Department of Revenue Office toll-free for one-on-one help: Telephone Information Center 1-800-647-7706.

#### **WAC 458-20-17001**

Government contracting -- Construction, installations, or improvements to government real property.

(1) Special business and occupation tax applications and special sales/use tax applications pertain for prime and subcontractors who perform certain construction, installation, and improvements to real property of or for the United States, its instrumentalities, or a county or city housing authority created pursuant to chapter 35.82 RCW. These specific construction activities are excluded from the definition of "sale at retail" under RCW 82.04.050. All other sales to the United States, its agencies or instrumentalities are taxable as retail sales or wholesale sales, as appropriate. See WAC 458-20-190.

(2) The definitions of terms and general provisions contained in WAC 458-20-170 apply equally for this rule, as appropriate. In addition, the terms, "clearing land" and "moving earth" include well drilling, core drilling, and hole digging, whether or not casing materials are installed and any grading or clearing of land, including the razing of buildings or other structures.

#### **Business and Occupation Tax**

(3) Amounts derived from constructing, repairing, decorating, or improving new or existing buildings or other structures, including installing or attaching tangible personal property therein or thereto, and clearing land or moving earth, of or for the United States, its instrumentalities, or county or city housing authorities of chapter 35.82 RCW are taxable under the government contracting classification of business and occupation tax. The measure of the tax is the gross contract price.

(4) Government contractors who manufacture or produce any tangible personal property for their own commercial or industrial use as consumers in performing government contracting activities are subject to the manufacturing classification of business and occupation tax measured by the value of the property manufactured or produced. See also, WAC 458-20-134. The manufacturing tax applies even though the property manufactured or produced for commercial use may be subsequently incorporated into buildings or other structures under the government contract and may thereby enhance the gross contract price.

#### **Retail Sales Tax**

(5) The retail sales tax does not apply to the gross contract price, or any part thereof, for any business activities taxable under the government contracting classification. Prime and subcontractors who perform such activities are themselves included within the statutory definition of "consumer" under RCW 82.04.190 and are required to pay retail sales tax upon all purchases of materials, including prefabricated and precast items, equipment, and other tangible personal property which is installed, applied, attached, or otherwise incorporated in their government contracting work. This applies for all such purchases of tangible personal property for installation, etc., even though the full purchase price of such property will be reimbursed by the government or housing authority in the gross contract price. It also applies notwithstanding that the contract may contain an immediate title vesting clause which provides that the title to the property vests in the government or housing authority immediately upon its acquisition by the contractor.

(6) Also, the retail sales tax must be paid by government contractors upon their purchases and leases or rentals of tools, consumables, and other tangible personal property used by them as consumers in performing government contracting.

#### **Use Tax**

(7) The use tax applies upon the value of all materials, equipment, and other tangible personal property purchased at retail, acquired as a bailee or donee, or manufactured or produced by the contractor for commercial or industrial use in performing government contracting and upon which no retail sales tax has been paid by the contractor, its bailor or donor.

(8) Thus the use tax applies to all property provided by the federal government to the contractor for installation or inclusion in the contract work as well as to all government provided tooling.

(9) The use tax is to be reported and paid by the government contractor who actually installs or applies the property to the contract. Where the actual installing contractor pays the tax, no further use tax is due upon such property by any other contractor.

(10) Note to contractors: The United States Supreme Court has sustained the government contracting tax applications for this state, even though the ultimate economic burden of the tax is borne by the United States Government (Washington v. US, 75 L.Ed 2d 264, 1983).

(11) This rule does not apply to public road construction. See WAC 458-20-171.  
[Statutory Authority: RCW 82.32.300. 86-10-016 (Order ET 86-9), § 458-20-17001, filed 5/1/86.]

**SECTION 3 - CLAUSE**

- A. The work to be performed under this contract is subject to the requirements of Section 3 of the Housing and Urban Development Act of 1968, as amended, 12 U.S.C. 1701u (Section 3) as implemented by HUD under 24 CFR Part 75 (collectively, the “Section 3 Regulations”). The purpose of Section 3 is to ensure that employment and other economic opportunities generated by HUD assistance or HUD- assisted projects covered by Section 3, shall, to the greatest extent feasible, be directed to low- and very low-income persons, including persons who are recipients of HUD assistance for housing, with preference for both targeted workers living in the service area or neighborhood of the Development and YouthBuild participants.
- B. The parties to this contract agree to comply with Section 3 Regulations. As evidenced by their execution of this contract, the parties to this contract certify that they are under no contractual obligation or other impediment that would prevent them from complying with Section 3 Regulations.
- C. The Contractor agrees to send to each labor organization or representative of workers with which the Contractor has a collective bargaining agreement or other understanding, if any, a notice advising the labor organization or workers' representative of the Contractor's commitments under this Section 3 clause, and will post copies of the notice in conspicuous places at the work site where both employees and applicants for training and employment positions can see the notice. The notice shall describe the Section 3 preference, shall set forth minimum number and job titles subject to hire, availability of apprenticeship and training positions, the qualifications for each; and the name and location of the person(s) taking applications for each of the positions; and the anticipated date the work shall begin.
- D. The Contractor agrees to include this Section 3 clause in every subcontract subject to compliance with Section 3 Regulations, and agrees to take appropriate action, as provided in an applicable provision of the subcontract or in this Section 3 clause, upon a finding that the subcontractor is in violation of Section 3 Regulations. The Contractor will not subcontract with any subcontractor where the Contractor has notice or knowledge that the subcontractor has been found in violation of Section 3 Regulations.
- E. The Contractor will certify that any vacant employment positions, including training positions, that are filled; (1) after the Contractor is selected but before the contract is executed, and (2) with persons other than those to whom Section 3 Regulations require employment opportunities to be directed, were not filled to circumvent the Contractor's obligations under Section 3 Regulations.
- F. Noncompliance with HUD's Section 3 Regulations may result in sanctions, termination of this contract for default, and debarment or suspension from future HUD assisted contracts.
- G. Section 3 Employment and Training. Without limiting Contractor’s obligation to comply with Section 3 Regulations, the Contractor specifically agrees to use best efforts to provide employment and training opportunities to Section 3 workers in the following order of priority:
1. To residents of the KCHA development where the work is being performed;
  2. To residents of other KCHA developments or for residents of Section 8–assisted housing managed by KCHA;
  3. To participants in YouthBuild programs; and

4. To low- and very low-income persons residing within the Puget Sound Region.
- H. Section 3 Contracting. Without limiting Contractor’s obligation to comply with Section 3 Regulations, Contractor specifically agrees to use best efforts to award contracts and subcontracts to business concerns that provide economic opportunities to Section 3 workers in the following order of priority:
1. To Section 3 business concerns that provide economic opportunities for KCHA residents of the development where the work is being performed;
  2. To Section 3 business concerns that provide economic opportunities for KCHA residents of other KCHA developments or Section-8 assisted housing managed by KCHA;
  3. To YouthBuild programs; and
  4. To Section 3 business concerns that provide economic opportunities to Section 3 workers residing within the Puget Sound Region.

## SECTION 3 – SUPPLEMENTAL INSTRUCTIONS TO BIDDERS

### LOCAL RESIDENT HIRING AND CONTRACTING (SECTION 3) REQUIREMENTS:

The Owner’s or King County Housing Authority’s (KCHA) goal for this project is to participate in Section 3 activities by including efforts that will provide employment opportunities to Section 3 workers and contracting opportunities to Section 3 businesses. (Section 3 workers and Section 3 Businesses are defined below and in 24 CFR 75.)

The Contractor and its Subcontractors at all tiers for this specific contract will partner with the Owner to contribute to the Owner’s overall “Section 3” goals, as described below.

Because local hiring and contracting requirements are defined under Section 3 of the Housing and Community Development Act of 1968, these requirements are commonly referred to as Section 3. The definitions and goals are defined in Sections A and B below. Section C describes the process. Section D discusses consequences of non-compliance with Section 3 goals and Section E describes some local hiring resources. For more information on the Owner’s employment and training efforts, or compliance with Section 3, please contact KCHA by email at [Section3@kcha.org](mailto:Section3@kcha.org).

#### A. Section 3 Definitions

For the purposes of this solicitation:

1. “Section 3 worker” means any worker who currently fits or when hired within the past five years fit at least one of the following categories, as documented:
  - a. The worker's income for the previous or annualized calendar year is below the income limit established by HUD. (See Pg. 4 of this section for HUD income limits)
  - b. The worker is employed by a Section 3 business concern.
  - c. The worker is a YouthBuild participant.
2. “Targeted Section 3 worker” means a Section 3 worker who is:
  - a. A worker employed by a Section 3 business concern; or
  - b. A worker who currently fits or when hired fit at least one of the following categories, as documented within the past five years:
    - i. A resident of public housing or Section 8–assisted housing;
    - ii. A resident of other public housing projects or Section 8–assisted housing managed by the PHA that is providing the assistance; or
    - iii. A YouthBuild participant.
3. “Business concern” means a business entity formed in accordance with State law, and which is licensed under State, county, or municipal law to engage in the type of business activity for which it was formed.
4. “Section 3 business concern” means a business concern meeting at least one of the following criteria, documented within the last six-month period:
  - a. It is at least 51 percent owned and controlled by low- or very low-income persons;
  - b. Over 75 percent of the labor hours performed for the business over the prior three-month period are performed by Section 3 workers; or
  - c. It is a business at least 51 percent owned and controlled by current public housing residents or residents who currently live in Section 8–assisted housing.
5. The greatest extent feasible means:
  - a. Completing and submitting a Section 3 Work Plan to designated Owner staff prior to contract signing (template to be provided by the Owner).
  - b. If contracting with Section 3 business concerns:
    - i. Placing qualified business enterprises on solicitation lists.

- ii. Dividing total requirements, when economically feasible, into smaller tasks or quantities to permit maximum participation of qualified Section 3 businesses.
- iii. Using the services and assistance of the U.S. Small Business Administration, the Minority Business Development Agency of the U.S. Department of Commerce and State and local governmental small business agencies to identify potential Section 3 businesses.
- iv. Ensuring that small and minority businesses and women’s business enterprises are solicited whenever they are potential sources.
- c. If hiring Section 3 workers:
  - i. Post job opportunities for a mutually agreed upon length of time through the Owner’s employment agency service partners and at project site as appropriate.
  - ii. Conduct interviews with qualified Section 3 workers.
  - iii. Notify designated Owner (KCHA) staff of all new hires.
- d. For both: Complete Section 3 compliance and tracking paperwork as necessary.

## **B. Section 3 Goals**

The Owner will require, to the greatest extent feasible, for the Contractor to demonstrate participation in the local hiring and contracting requirements as defined under Section 3 of the Housing and Community Development Act of 1968.

1. Bidders shall demonstrate compliance with the Section 3 goals by making a best faith effort to achieve the following benchmarks:
  - a. Twenty-five (25) percent or more of the total number of labor hours worked by all workers are Section 3 workers; and
  - b. Five (5) percent or more of the total number of labor hours worked by all workers are Targeted Section 3 workers.
2. The successful bidder and covered subcontractors shall direct their efforts to provide Section 3 employment opportunities to Section 3 workers in the following order of priority:
  - a. First Priority: Current residents of KCHA development(s) benefitting from project.
  - b. Second Priority: Other Owner public housing and Section 8 voucher- assisted residents.
  - c. Third Priority: Participants in HUD Youthbuild programs.
  - d. Fourth Priority: Other low or very low income individuals in the Housing Authorities metropolitan area (Puget Sound region) who are at or below the Area’s Low Income calculation.
3. The Contractor and covered subcontractors shall direct their efforts to award contracts to Section 3 business concerns in the following order of priority:
  - a. First Priority: To Section 3 business concern that provides economic opportunities for KCHA residents at the site(s) where the work will take place.
  - b. Second Priority: To Section 3 business concerns that provide economic opportunities for residents of other KCHA developments or Section–8 assisted housing managed by KCHA.
  - c. Third Priority: A subcontractor that is a HUD Youthbuild company.
  - d. Fourth Priority: To Section 3 business concerns that provide economic opportunities to Section 3 workers residing within the metropolitan area (Puget Sound).
4. Sealed Bidding  
In order for KCHA to meet or exceed its adopted goal that 3% of all non-construction contracts and 10% of construction contracts paid in whole or in part with HUD funds be awarded to Section 3 businesses, KCHA may elect, on a contract-by-contract basis, to award a competitively bid contract to a responsible bidder other than the lowest responsive bidder by using the following procedure:

Bids shall be solicited from both Section 3 and non-Section 3 business concerns. KCHA may award the contract to the qualified Section 3 business concern with the highest priority ranking

and with the lowest responsive bid if:

- a. the specific project or KCHA as an agency is otherwise not expected to meet Section 3 utilization goals; and,
- b. the bid is within the maximum total contract price established in KCHA’s budget for the specific project for which bids are being taken; and,
- c. the sources of funds for the project are such that there are no conflicts between this procedure and applicable state law; and,
- d. the bid is not more than five percent (5%) higher than the total bid price for the lowest responsive bid from any responsible, bidder.

If no responsive bid by a Section 3 business concern meets the requirements above, the contract shall be awarded to a responsible bidder with the lowest responsive bid.

**C. The Process**

1. Contract is awarded to lowest responsible Bidder.
2. Section 3 orientation with Owner. Once the Notice of Intent to Award has been issued to the successful Bidder, Owner’s staff will contact that Bidder and arrange for a meeting to discuss local hiring and contracting goals and strategies in greater detail. At this meeting, the Contractor will be provided a packet that will include a Section 3 overview, Section 3 certification form, and all Section 3 compliance and tracking forms that will be used throughout the contract.
3. Contractor reports on Section 3 activities monthly.

**D. Penalties for Non-compliance**

Owner’s commitment to this program is reflected in part by the cost of administering the program. Failure to make a good faith effort to the greatest extent feasible negates such funding and impairs the Owner’s efforts to promote workforce diversity and to provide fair and equal opportunities to the public as a whole as a result of the expenditure of public funds. Therefore, if awarded this contract, the parties will mutually agree that failure to meet the requirements, including but not limited to the submission of required documentation, constitutes a material breach of contract. In the event of such breach, Owner may take any or all of the actions as contained in the Contract Documents.

**E. Local Hiring Resources**

Contact KCHA by email at [Section3@kcha.org](mailto:Section3@kcha.org) to obtain a list of local hiring resources.

**SECTION 3 – 2025 INCOME GUIDELINES**

Location	Income Limit 1 person		
	Extremely Low Income	Very Low Income	Low Income
Kitsap County (Bremerton, Silverdale)	\$26,150	\$43,550	\$69,650
King/ Snohomish Counties (Seattle, Bellevue, Everett)	\$33,050	\$55,000	\$84,850
Pierce County (Tacoma)	\$25,400	\$42,300	\$67,700
Skagit County (Sedro-Woolley)	\$23,000	\$38,250	\$61,250
Thurston County (Olympia, Tumwater)	\$24,500	\$40,850	\$65,350

## PROGRESS PAYMENT SUSPENSION CRITERIA

CRITERIA will include:

1. Non-submittal of Certified Payroll documents (see Informational Form A.12)
2. Non-submittal of Section 3 Labor Hours Benchmark Status Report (see Section C for sample)
3. No lien release with Application for Payment
4. Insurance expires
5. Federal and/or State liens on general contractor
6. Suspension/expiration of WA State contractor's license
7. Work not accomplished
8. Work not approved/ accepted
9. Repeated safety violations not resolved if warnings from KCHA are ignored
10. Incorrect Application for Payment or invoice (whichever is applicable)
11. Non-submittal of the GC Certification Upon Application for Payment (see Section E, Division 1 for sample of KCHA Pay Application which includes the continuation sheet, the payment application and the GC Certification)

**EXECUTIVE ORDER 11246 (as AMENDED)**

---DISCLAIMER--- <http://www.dol.gov/general/disclaim#statutory>

**Executive Order 11246 - Equal Employment Opportunity**

SOURCE: The provisions of Executive Order 11246 of Sept. 24, 1965, appear at 30 FR 12319, 12935, 3 CFR, 1964-1965 Comp., p.339, unless otherwise noted.

Under and by virtue of the authority vested in me as President of the United States by the Constitution and statutes of the United States, it is ordered as follows:

**Part I - Nondiscrimination in Government Employment**

[Part I superseded by EO 11478 of Aug. 8, 1969, 34 FR 12985, 3 CFR, 1966-1970 Comp., p. 803]

**Part II - Nondiscrimination in Employment by Government Contractors and Subcontractors****Subpart A - Duties of the Secretary of Labor**

**SEC. 201.** The Secretary of Labor shall be responsible for the administration and enforcement of Parts II and III of this Order. The Secretary shall adopt such rules and regulations and issue such orders as are deemed necessary and appropriate to achieve the purposes of Parts II and III of this Order.

[Sec. 201 amended by EO 12086 of Oct. 5, 1978, 43 FR 46501, 3 CFR, 1978 Comp., p. 230]

**Subpart B - Contractors' Agreements**

**SEC. 202.** Except in contracts exempted in accordance with Section 204 of this Order, all Government contracting agencies shall include in every Government contract hereafter entered into the following provisions:

During the performance of this contract, the contractor agrees as follows:

(1) The contractor will not discriminate against any employee or applicant for employment because of race, color, religion, sex, or national origin. The contractor will take affirmative action to ensure that applicants are employed, and that employees are treated during employment, without regard to their race, color, religion, sex or national origin. Such action shall include, but not be limited to the following: employment, upgrading, demotion, or transfer; recruitment or recruitment advertising; layoff or termination; rates of pay or other forms of compensation; and selection for training, including apprenticeship. The contractor agrees to post in conspicuous places, available to employees and applicants for employment, notices to be provided by the contracting officer setting forth the provisions of this nondiscrimination clause.

(2) The contractor will, in all solicitations or advancements for employees placed by or on behalf of the contractor, state that all qualified applicants will receive consideration for employment without regard to race, color, religion, sex or national origin.

(3) The contractor will send to each labor union or representative of workers with which he has a collective bargaining agreement or other contract or understanding, a notice, to be provided by the agency contracting officer, advising the labor union or workers' representative of the contractor's commitments under Section 202 of Executive Order No. 11246 of September 24, 1965, and shall post copies of the notice in conspicuous places available to employees and applicants for employment.

(4) The contractor will comply with all provisions of Executive Order No. 11246 of Sept. 24, 1965, and of the rules, regulations, and relevant orders of the Secretary of Labor.

(5) The contractor will furnish all information and reports required by Executive Order No. 11246 of September 24, 1965, and by the rules, regulations, and orders of the Secretary of Labor, or pursuant thereto, and will permit access to his books, records, and accounts by the contracting agency and the Secretary of Labor for purposes of investigation to ascertain compliance with such rules, regulations, and orders.

(6) In the event of the contractor's noncompliance with the nondiscrimination clauses of this contract or with any of such rules, regulations, or orders, this contract may be cancelled, terminated, or suspended in whole or in part and the contractor may be declared ineligible for further Government contracts in accordance with procedures authorized in Executive Order No. 11246 of Sept. 24, 1965, and such other sanctions may be imposed and remedies invoked as provided in Executive Order No. 11246 of September 24, 1965, or by rule, regulation, or order of the Secretary of Labor, or as otherwise provided by law.

(7) The contractor will include the provisions of paragraphs (1) through (7) in every subcontract or purchase order unless exempted by rules, regulations, or orders of the Secretary of Labor issued pursuant to Section 204 of Executive Order No. 11246 of September 24, 1965, so that such provisions will be binding upon each subcontractor or vendor. The contractor will take such action with respect to any subcontract or purchase order as may be directed by the Secretary of Labor as a means of enforcing such provisions including sanctions for noncompliance: Provided, however, that in the event the contractor becomes involved in, or is threatened with, litigation with a subcontractor or vendor as a result of such direction, the contractor may request the United States to enter into such litigation to protect the interests of the United States."

[Sec. 202 amended by EO 11375 of Oct. 13, 1967, 32 FR 14303, 3 CFR, 1966-1970 Comp., p. 684, EO 12086 of Oct. 5, 1978, 43 FR 46501, 3 CFR, 1978 Comp., p. 230]

**SEC. 203.** Each contractor having a contract containing the provisions prescribed in Section 202 shall file, and shall cause each of his subcontractors to file, Compliance Reports with the contracting agency or the Secretary of Labor as may be directed. Compliance Reports shall be filed within such times and shall contain such information as to the practices, policies, programs, and employment policies, programs, and employment statistics of the contractor and each subcontractor, and shall be in such form, as the Secretary of Labor may prescribe.

(b) Bidders or prospective contractors or subcontractors may be required to state whether they have participated in any previous contract subject to the provisions of this Order, or any preceding similar Executive order, and in that event to submit, on behalf of themselves and their proposed subcontractors, Compliance Reports prior to or as an initial part of their bid or negotiation of a contract.

(c) Whenever the contractor or subcontractor has a collective bargaining agreement or other contract or understanding with a labor union or an agency referring workers or providing or supervising apprenticeship or training for such workers, the Compliance Report shall include such information as to such labor union's or agency's practices and policies affecting compliance as the Secretary of Labor may prescribe: Provided, That to the extent such information is within the exclusive possession of a labor union or an agency referring workers or providing or supervising apprenticeship or training and such labor union or agency shall refuse to furnish such information to the contractor, the contractor shall so certify to the Secretary of Labor as part of its Compliance Report and shall set forth what efforts he has made to obtain such information.

(d) The Secretary of Labor may direct that any bidder or prospective contractor or subcontractor shall submit, as part of his Compliance Report, a statement in writing, signed by an authorized officer or agent on behalf of any labor union or any agency referring workers or providing or supervising apprenticeship or other training, with which the bidder or prospective contractor deals, with supporting information, to the effect that the signer's practices and policies do not discriminate on the grounds of race, color, religion, sex or national origin, and that the signer either will affirmatively cooperate in the implementation of the policy and provisions of this Order or that it consents and agrees that recruitment, employment, and the terms and conditions of employment under the proposed contract shall be in accordance with the purposes and

provisions of the order. In the event that the union, or the agency shall refuse to execute such a statement, the Compliance Report shall so certify and set forth what efforts have been made to secure such a statement and such additional factual material as the Secretary of Labor may require.

[Sec. 203 amended by EO 11375 of Oct. 13, 1967, 32 FR 14303, 3 CFR, 1966-1970 Comp., p. 684; EO 12086 of Oct. 5, 1978, 43 FR 46501, 3 CFR, 1978 Comp., p. 230]

**SEC. 204 (a)** The Secretary of Labor may, when the Secretary deems that special circumstances in the national interest so require, exempt a contracting agency from the requirement of including any or all of the provisions of Section 202 of this **Order** in any specific contract, subcontract, or purchase **order**.

(b) The Secretary of Labor may, by rule or regulation, exempt certain classes of contracts, subcontracts, or purchase orders (1) whenever work is to be or has been performed outside the United States and no recruitment of workers within the limits of the United States is involved; (2) for standard commercial supplies or raw materials; (3) involving less than specified amounts of money or specified numbers of workers; or (4) to the extent that they involve subcontracts below a specified tier.

(c) Section 202 of this **Order** shall not apply to a Government contractor or subcontractor that is a religious corporation, association, educational institution, or society, with respect to the employment of individuals of a particular religion to perform work connected with the carrying on by such corporation, association, educational institution, or society of its activities. Such contractors and subcontractors are not exempted or excused from complying with the other requirements contained in this **Order**.

(d) The Secretary of Labor may also provide, by rule, regulation, or **order**, for the exemption of facilities of a contractor that are in all respects separate and distinct from activities of the contractor related to the performance of the contract: provided, that such an exemption will not interfere with or impede the effectuation of the purposes of this **Order**: and provided further, that in the absence of such an exemption all facilities shall be covered by the provisions of this **Order**."

[Sec. 204 amended by EO 13279 of Dec. 16, 2002, 67 FR 77141, 3 CFR, 2002 Comp., p. 77141 - 77144]

### **Subpart C - Powers and Duties of the Secretary of Labor and the Contracting Agencies**

**SEC. 205.** The Secretary of Labor shall be responsible for securing compliance by all Government contractors and subcontractors with this Order and any implementing rules or regulations. All contracting agencies shall comply with the terms of this Order and any implementing rules, regulations, or orders of the Secretary of Labor. Contracting agencies shall cooperate with the Secretary of Labor and shall furnish such information and assistance as the Secretary may require.

[Sec. 205 amended by EO 12086 of Oct. 5, 1978, 43 FR 46501, 3 CFR, 1978 Comp., p. 230]

**SEC. 206.** The Secretary of Labor may investigate the employment practices of any Government contractor or subcontractor to determine whether or not the contractual provisions specified in Section 202 of this Order have been violated. Such investigation shall be conducted in accordance with the procedures established by the Secretary of Labor.

(b) The Secretary of Labor may receive and investigate complaints by employees or prospective employees of a Government contractor or subcontractor which allege discrimination contrary to the contractual provisions specified in Section 202 of this Order.

[Sec. 206 amended by EO 12086 of Oct. 5, 1978, 43 FR 46501, 3 CFR, 1978 Comp., p. 230]

**SEC. 207.** The Secretary of Labor shall use his/her best efforts, directly and through interested Federal, State, and local agencies, contractors, and all other available instrumentalities to cause any labor union

engaged in work under Government contracts or any agency referring workers or providing or supervising apprenticeship or training for or in the course of such work to cooperate in the implementation of the purposes of this Order. The Secretary of Labor shall, in appropriate cases, notify the Equal Employment Opportunity Commission, the Department of Justice, or other appropriate Federal agencies whenever it has reason to believe that the practices of any such labor organization or agency violate Title VI or Title VII of the Civil Rights Act of 1964 or other provision of Federal law.

[Sec. 207 amended by EO 12086 of Oct. 5, 1978, 43 FR 46501, 3 CFR, 1978 Comp., p. 230]

**SEC. 208.** The Secretary of Labor, or any agency, officer, or employee in the executive branch of the Government designated by rule, regulation, or order of the Secretary, may hold such hearings, public or private, as the Secretary may deem advisable for compliance, enforcement, or educational purposes.

(b) The Secretary of Labor may hold, or cause to be held, hearings in accordance with Subsection of this Section prior to imposing, ordering, or recommending the imposition of penalties and sanctions under this Order. No order for debarment of any contractor from further Government contracts under Section 209(6) shall be made without affording the contractor an opportunity for a hearing.

#### **Subpart D - Sanctions and Penalties**

**SEC. 209.** In accordance with such rules, regulations, or orders as the Secretary of Labor may issue or adopt, the Secretary may:

(1) Publish, or cause to be published, the names of contractors or unions which it has concluded have complied or have failed to comply with the provisions of this Order or of the rules, regulations, and orders of the Secretary of Labor.

(2) Recommend to the Department of Justice that, in cases in which there is substantial or material violation or the threat of substantial or material violation of the contractual provisions set forth in Section 202 of this Order, appropriate proceedings be brought to enforce those provisions, including the enjoining, within the limitations of applicable law, of organizations, individuals, or groups who prevent directly or indirectly, or seek to prevent directly or indirectly, compliance with the provisions of this Order.

(3) Recommend to the Equal Employment Opportunity Commission or the Department of Justice that appropriate proceedings be instituted under Title VII of the Civil Rights Act of 1964.

(4) Recommend to the Department of Justice that criminal proceedings be brought for the furnishing of false information to any contracting agency or to the Secretary of Labor as the case may be.

(5) After consulting with the contracting agency, direct the contracting agency to cancel, terminate, suspend, or cause to be cancelled, terminated, or suspended, any contract, or any portion or portions thereof, for failure of the contractor or subcontractor to comply with equal employment opportunity provisions of the contract. Contracts may be cancelled, terminated, or suspended absolutely or continuance of contracts may be conditioned upon a program for future compliance approved by the Secretary of Labor.

(6) Provide that any contracting agency shall refrain from entering into further contracts, or extensions or other modifications of existing contracts, with any noncomplying contractor, until such contractor has satisfied the Secretary of Labor that such contractor has established and will carry out personnel and employment policies in compliance with the provisions of this Order.

(b) Pursuant to rules and regulations prescribed by the Secretary of Labor, the Secretary shall make reasonable efforts, within a reasonable time limitation, to secure compliance with the contract provisions of this Order by methods of conference, conciliation, mediation, and persuasion before proceedings shall be instituted under subsection (a)(2) of this Section, or before a contract shall be cancelled or terminated in whole or in part under subsection (a)(5) of this Section.

[Sec. 209 amended by EO 12086 of Oct. 5, 1978, 43 FR 46501, 3 CFR, 1978 Comp., p. 230]

**SEC. 210.** Whenever the Secretary of Labor makes a determination under Section 209, the Secretary shall promptly notify the appropriate agency. The agency shall take the action directed by the Secretary and shall report the results of the action it has taken to the Secretary of Labor within such time as the Secretary shall specify. If the contracting agency fails to take the action directed within thirty days, the Secretary may take the action directly.

[Sec. 210 amended by EO 12086 of Oct. 5, 1978, 43 FR 46501, 3 CFR, 1978 Comp., p. 230]

**SEC. 211.** If the Secretary shall so direct, contracting agencies shall not enter into contracts with any bidder or prospective contractor unless the bidder or prospective contractor has satisfactorily complied with the provisions of this Order or submits a program for compliance acceptable to the Secretary of Labor.

[Sec. 211 amended by EO 12086 of Oct. 5, 1978, 43 FR 46501, 3 CFR, 1978 Comp., p. 230]

**SEC. 212.** When a contract has been cancelled or terminated under Section 209(a)(5) or a contractor has been debarred from further Government contracts under Section 209(a)(6) of this Order, because of noncompliance with the contract provisions specified in Section 202 of this Order, the Secretary of Labor shall promptly notify the Comptroller General of the United States.

[Sec. 212 amended by EO 12086 of Oct. 5, 1978, 43 FR 46501, 3 CFR, 1978 Comp., p. 230]

#### **Subpart E - Certificates of Merit**

**SEC. 213.** The Secretary of Labor may provide for issuance of a United States Government Certificate of Merit to employers or labor unions, or other agencies which are or may hereafter be engaged in work under Government contracts, if the Secretary is satisfied that the personnel and employment practices of the employer, or that the personnel, training, apprenticeship, membership, grievance and representation, upgrading, and other practices and policies of the labor union or other agency conform to the purposes and provisions of this Order.

**SEC. 214.** Any Certificate of Merit may at any time be suspended or revoked by the Secretary of Labor if the holder thereof, in the judgment of the Secretary, has failed to comply with the provisions of this Order.

**SEC. 215.** The Secretary of Labor may provide for the exemption of any employer, labor union, or other agency from any reporting requirements imposed under or pursuant to this Order if such employer, labor union, or other agency has been awarded a Certificate of Merit which has not been suspended or revoked.

#### **Part III - Nondiscrimination Provisions in Federally Assisted Construction Contracts**

**SEC. 301.** Each executive department and agency, which administers a program involving Federal financial assistance shall require as a condition for the approval of any grant, contract, loan, insurance, or guarantee thereunder, which may involve a construction contract, that the applicant for Federal assistance undertake and agree to incorporate, or cause to be incorporated, into all construction contracts paid for in whole or in part with funds obtained from the Federal Government or borrowed on the credit of the Federal Government pursuant to such grant, contract, loan, insurance, or guarantee, or undertaken pursuant to any Federal program involving such grant, contract, loan, insurance, or guarantee, the provisions prescribed for Government contracts by Section 202 of this Order or such modification thereof, preserving in substance the contractor's obligations thereunder, as may be approved by the Secretary of Labor, together with such additional provisions as the Secretary deems appropriate to establish and protect the interest of the United States in the enforcement of those obligations. Each such applicant shall also undertake and agree (1) to assist and cooperate actively with the Secretary of Labor in obtaining the compliance of contractors and subcontractors with those contract provisions and with the rules, regulations and relevant orders of the Secretary, (2) to obtain and to furnish to the Secretary of Labor such information as the Secretary may require

for the supervision of such compliance, (3) to carry out sanctions and penalties for violation of such obligations imposed upon contractors and subcontractors by the Secretary of Labor pursuant to Part II, Subpart D, of this Order, and (4) to refrain from entering into any contract subject to this Order, or extension or other modification of such a contract with a contractor debarred from Government contracts under Part II, Subpart D, of this Order.

[Sec. 301 amended by EO 12086 of Oct. 5, 1978, 43 FR 46501, 3 CFR, 1978 Comp., p. 230]

**SEC. 302.** "Construction contract" as used in this Order means any contract for the construction, rehabilitation, alteration, conversion, extension, or repair of buildings, highways, or other improvements to real property.

(b) The provisions of Part II of this Order shall apply to such construction contracts, and for purposes of such application the administering department or agency shall be considered the contracting agency referred to therein.

(c) The term "applicant" as used in this Order means an applicant for Federal assistance or, as determined by agency regulation, other program participant, with respect to whom an application for any grant, contract, loan, insurance, or guarantee is not finally acted upon prior to the effective date of this Part, and it includes such an applicant after he/she becomes a recipient of such Federal assistance.

**SEC. 303.** The Secretary of Labor shall be responsible for obtaining the compliance of such applicants with their undertakings under this Order. Each administering department and agency is directed to cooperate with the Secretary of Labor and to furnish the Secretary such information and assistance as the Secretary may require in the performance of the Secretary's functions under this Order.

(b) In the event an applicant fails and refuses to comply with the applicant's undertakings pursuant to this Order, the Secretary of Labor may, after consulting with the administering department or agency, take any or all of the following actions: (1) direct any administering department or agency to cancel, terminate, or suspend in whole or in part the agreement, contract or other arrangement with such applicant with respect to which the failure or refusal occurred; (2) direct any administering department or agency to refrain from extending any further assistance to the applicant under the program with respect to which the failure or refusal occurred until satisfactory assurance of future compliance has been received by the Secretary of Labor from such applicant; and (3) refer the case to the Department of Justice or the Equal Employment Opportunity Commission for appropriate law enforcement or other proceedings.

(c) In no case shall action be taken with respect to an applicant pursuant to clause (1) or (2) of subsection (b) without notice and opportunity for hearing.

[Sec. 303 amended by EO 12086 of Oct. 5, 1978, 43 FR 46501, 3 CFR, 1978 Comp., p. 230]

**SEC. 304.** Any executive department or agency which imposes by rule, regulation, or order requirements of nondiscrimination in employment, other than requirements imposed pursuant to this Order, may delegate to the Secretary of Labor by agreement such responsibilities with respect to compliance standards, reports, and procedures as would tend to bring the administration of such requirements into conformity with the administration of requirements imposed under this Order: Provided, That actions to effect compliance by recipients of Federal financial assistance with requirements imposed pursuant to Title VI of the Civil Rights Act of 1964 shall be taken in conformity with the procedures and limitations prescribed in Section 602 thereof and the regulations of the administering department or agency issued thereunder.

#### **Part IV - Miscellaneous**

**SEC. 401.** The Secretary of Labor may delegate to any officer, agency, or employee in the Executive branch of the Government, any function or duty of the Secretary under Parts II and III of this Order.

[Sec. 401 amended by EO 12086 of Oct. 5, 1978, 43 FR 46501, 3 CFR, 1978 Comp., p. 230]

**SEC. 402.** The Secretary of Labor shall provide administrative support for the execution of the program known as the "Plans for Progress."

**SEC. 403.** Executive Orders Nos. 10590 (January 19, 1955), 10722 (August 5, 1957), 10925 (March 6, 1961), 11114 (June 22, 1963), and 11162 (July 28, 1964), are hereby superseded and the President's Committee on Equal Employment Opportunity established by Executive Order No. 10925 is hereby abolished. All records and property in the custody of the Committee shall be transferred to the Office of Personnel Management and the Secretary of Labor, as appropriate.

(b) Nothing in this Order shall be deemed to relieve any person of any obligation assumed or imposed under or pursuant to any Executive Order superseded by this Order. All rules, regulations, orders, instructions, designations, and other directives issued by the President's Committee on Equal Employment Opportunity and those issued by the heads of various departments or agencies under or pursuant to any of the Executive orders superseded by this Order, shall, to the extent that they are not inconsistent with this Order, remain in full force and effect unless and until revoked or superseded by appropriate authority. References in such directives to provisions of the superseded orders shall be deemed to be references to the comparable provisions of this Order.

[Sec. 403 amended by EO 12107 of Dec. 28, 1978, 44 FR 1055, 3 CFR, 1978 Comp., p. 264]

**SEC. 404.** The General Services Administration shall take appropriate action to revise the standard Government contract forms to accord with the provisions of this Order and of the rules and regulations of the Secretary of Labor.

**SEC. 405.** This Order shall become effective thirty days after the date of this Order.

## EXECUTIVE ORDER 13496

### New Employee Notification Requirements for Federal Contractors and Subcontractors

Under Department of Labor regulations, [www.gpo.gov/fdsys/pkg/FR-2010-05-20/pdf/2010-11639.pdf](http://www.gpo.gov/fdsys/pkg/FR-2010-05-20/pdf/2010-11639.pdf), contractors holding contracts with the Federal government and their subcontractors are required, beginning on June 21, 2010, to post notices informing employees of their rights under the National Labor Relations Act (NLRA). The notice to employees required by the regulations inform employees about their rights under the NLRA to form, join and assist a union and to bargain collectively with their employer; provides examples of unlawful employer and union conduct that interferes with those rights; and indicates how employees can contact the National Labor Relations Board, the Federal agency that enforces those rights, with questions or to file complaints. Contractors that violate the Labor Department's regulations requiring employee notification of these rights may be subject to sanctions, including suspension or cancellation of the contract.

The regulations require Federal contractors:

1. to post the required employee notice conspicuously in and around their plants and offices so that it is prominent and readily seen by employees who are covered by the NLRA and who engage in contract-related activity;
2. to post the required notice electronically if they communicate with employees electronically, which requires posting a link to the Department of Labor's website containing the employee notice where they customarily place other electronic notices to employees about their jobs; and
3. to insert provisions in their subcontracts that require their subcontractors to comply with the same posting requirements as well.

Contractors and subcontractors may obtain the required poster in any of the three ways. The Labor Department will print posters and provide them to Federal contracting departments and agencies for supply to contractors and subcontractors. In addition, contractors and subcontractors can request posters from the field offices of the Labor Department's Office of Federal Contract Compliance Programs (<http://www.dol.gov/ofccp/contacts/ofnation2.htm>), or Office of Labor-Management Standards (OLMS) (<http://www.dol.gov/olms/contacts/lmskeyp.htm>). Finally, contractors and subcontractors can acquire the poster from OLMS' website by downloading it from <http://www.dol.gov/olms> or by calling (202) 693-0123. Compliance information for contractors and subcontractors can be found at OFCCP's website [Construction Compliance Checks Frequently Asked Questions | U.S. Department of Labor \(dol.gov\)](#)

### EXECUTIVE ORDER 13496 - FREQUENTLY ASKED QUESTIONS

[Executive Order 13496 Frequently Asked Questions | U.S. Department of Labor \(dol.gov\)](#)

## REQUIREMENTS FOR PUBLIC WORKS PROJECTS

**REQUIREMENTS FOR PUBLIC WORKS PROJECTS** – All projects require that the contractor and all subcontractors performing labor on the project site must file the Statement of Intent with L&I regardless of the wage determination is set as HUD Non-Routine Maintenance, State Prevailing wages or Davis-Bacon.

### **Statement of Intent to Pay Prevailing Wages - filed at the start of the project**

- A. **Filed Immediately** after the contract is awarded and before work begins, if that is possible. **NO PAYMENTS CAN BE MADE** until the contractor has submitted an Intent form that has been approved by the Industrial Statistician.
- B. **SUBCONTRACTORS must file using the PRIME CONTRACTOR’S “Form ID Number” after the PRIME has received approval for their Statement of Intent.**
- C. Wage payment requirements for this project are determined to be
  - 1. **Davis-Bacon (NA)**
  - 2. **HUD Non-Routine Maintenance**
    - a. The Intent is then filed with the question *“Is this a Housing Act of 1937 Project?” answered as Yes.*
    - b. See the Informational Form A.13b for the sample of Intent to Pay Prevailing Wages with the highlighted statement shown on the form.

### **Certified Payroll - filed each week for the duration of the project**

- A. Submitted on a weekly basis, beginning with the first week that the Contractor works on the Project, and for every week afterward until the Contractor completes the Work.
- B. Consisting of a certified payroll report and a statement of compliance.
- C. See Informational Form A.12c for more information.  
*NOTE: These requirements will also apply to HUD Non-Routine Maintenance Wages.*

### **Affidavit of Wages Paid - filed at the end of the project**

- A. Submitted at the end of the project once all of the work has been completed, showing the wages paid to employees who worked on the project.

## SCREEN SHOTS OF INTENT

### File Intent: Enter the Project Details

STEP 1 Select Contract Type > STEP 2 Project Details > STEP 3 Intent Details > STEP 4 Add Wages > STEP 5 Review Intent > STEP 6 Payment Details >

#### Project Details

##### Contract Type

Bid Due Date (required) ⓘ

Contract Award Date (required) ⓘ

Awarding Agency

Awarding Agency Address

Awarding Agency Contact Name (required)

Awarding Agency Contact Phone Number (required)

Awarding Agency Contract Number (required) ⓘ

Project Name (required)

Is apprentice utilization required? (required)

Is OMWBE utilization required? (required)

Is this a Housing Act of 1937 project? (required)

Project Site Address or Directions ⓘ

##### Bid-Build (Traditional)

mm/dd/yyyy

mm/dd/yyyy

KING COUNTY HOUSING AUTHORITY

700 ANDOVER PARK SW TUKWILA, WA - 98188

 Ext 

Yes  No

Yes  No

Yes  No

0/1000

## DAVIS BACON & RELATED ACTS PROVISIONS; CONTRACT WORK HOURS & SAFETY STANDARDS ACT; GENERAL INFORMATION

### A. The Davis-Bacon Act (DBA)\*

The DBA, enacted in 1931, applies to contracts in excess of \$2,000 for construction, alteration, and/or repair of public buildings or public works, including painting and decorating, to which the United States or the District of Columbia is a party. This type of applicability is referred to as direct Davis-Bacon Act or DBA coverage. An example of DBA coverage is when HUD contracts directly for repairs to HUD-owned properties. HUD's Office of the Chief Procurement Officer manages these types of contracts. The DBA requires that the advertised specifications for such contracts contain a provision stating that the minimum wages to be paid to various classes of laborers and mechanics must be based upon the wages found to be prevailing by the Secretary of Labor.

Most HUD construction work is not covered by the DBA since HUD does not usually contract directly for construction work. Rather, Davis-Bacon wage rates apply to HUD programs because of prevailing wage requirements expressed in HUD "Related Acts" such as the U. S. Housing Act of 1937 and the Housing and Community Development Act of 1974, as amended. The Related Acts (referred to throughout this Guide as the Davis-Bacon and Related Acts or DBRA) are discussed further in Section 5.9.

The DBA includes provisions that:

1. Require the contractor or subcontractor to pay all mechanics and laborers at least once per week;
2. Prohibit contractors or subcontractors from taking deductions or rebates from wages earned by laborers and mechanics;
3. Require the contractor or subcontractor to pay Davis-Bacon wages to all laborers and mechanics employed on the site of the work regardless of their skill level, and regardless of any contractual relationship alleged to exist between the laborers and mechanics and the contractor or subcontractor;
4. Require the contractor or subcontractor to post the scale of wages to be paid (i.e., the applicable Davis-Bacon wage decision) in a prominent and accessible place at the work site;
5. Define prevailing wages to include fringe benefits;
6. Permit the withholding of payments due to the contractor on account of wage restitution that may be found due to the laborers and mechanics;
7. Permit the payment of wage restitution from amounts withheld from contract payments;
8. Permit the termination of the contract where it is found that any laborer or mechanic is underpaid; and
9. Permit the debarment of persons or firms found to have disregarded their obligations to employees and subcontractors.

### B. The Contract Work Hours and Safety Standards Act (CWHSSA)

The CWHSSA applies to both direct federal contracts and to federally-assisted contracts where those contracts require or involve the employment of laborers and mechanics and where federal wage standards (e.g., Davis-Bacon or HUD-determined prevailing wage rates) are applicable.

CWHSSA provisions apply to all laborers and mechanics, including watchmen and guards, employed by any contractor or subcontractor. CWHSSA also applies to maintenance laborers and mechanics employed by contractors or subcontractors engaged in the operation of Public Housing Agencies (PHA), Tribally Designated Housing Entities (TDHE), and Indian Housing Agencies

(IHA) developments. CWHSSA O/T provisions do not apply to laborers and mechanics employed directly by PHAs or IHAs. However, O/T provisions generally apply to these workers under the Fair Labor Standards Act (FLSA). HUD does not have authority to enforce FLSA violations. Refer complaints of FLSA violations to DOL, Wage and Hour Division.

CWHSSA provides that all O/T hours (defined as hours worked in excess of 40 during any workweek on the CWHSSA-covered project site) must be compensated at a rate not less than one and one-half times the regular basic rate of pay. Where CWHSSA O/T provisions are applicable, compensatory time in lieu of premium pay for O/T hours is not permissible. In the event of O/T violations, the CWHSSA renders the contractor liable to the underpaid workers for wage restitution and to the United States Government for liquidated damages computed per person per day at a rate that DOL publishes annually. It is a federal criminal misdemeanor to intentionally violate CWHSSA standards.

Exemptions:

1. CWHSSA O/T provisions do not apply where the federal assistance is only in the nature of a loan guarantee or insurance.
2. CWHSSA O/T provisions do not apply to prime contracts of \$100,000 or less.

\*The Davis Bacon provisions also apply to HUD-determined prevailing wage rates.

<http://www.ecfr.gov/current/title-29>

## C. GENERAL INFORMATION

### 1. Employer Responsibilities

- a. All employers (contractors, subcontractors, and any lower-tier subcontractors) are required to pay all laborers and mechanics employed or working on the site of the work unconditionally and not less often than once per week the full amount of wages and bona fide fringe benefits computed at rates not less than those contained in the wage decision.
- b. Employers must prepare, certify, and submit weekly payroll reports reflecting all the laborers and mechanics (employees) engaged in construction on the site of the work.
- c. Employers may also be required to submit related documentation in order to demonstrate compliance.

### 2. Agency Responsibilities

- a. State, tribal, and local contracting agencies (LCAs) that administer HUD programs agree to administer and enforce Davis-Bacon requirements as a condition for receiving HUD program assistance.
- b. Conduct on-site inspections including interviews with laborers and mechanics employed on the construction project. Ensure that the applicable Davis-Bacon wage decision, DOL's Davis-Bacon poster (Form WH-1321), and additional classifications are displayed at the job site.
- c. Review certified payroll reports (CPRs) and related documentation. Identify any discrepancies and/or violations. Ensure that any needed corrections are made promptly, including the payment of wage restitution as needed, and the assessment and collection of liquidated damages, as appropriate.
- d. Comply with all HUD requirements concerning statutory, program, and/or other requirements.

### 3. Definitions

#### a. Employee

Every person who performs the work of a laborer or mechanic is “employed” regardless of any contractual relationship that may be alleged to exist between a contractor or subcontractor and such person.

#### b. Working subcontractors

Persons who perform the work of laborers or mechanics and who represent themselves to be owners of businesses, sole proprietors, or self-employed are not exempt from prevailing wage requirements. These laborers and mechanics are “employed” and are entitled to the prevailing wage for the type of work they perform, and must be reported on the payroll report for their craft, hours of work, and wages paid.

#### c. Apprentice

A person employed and individually registered in a bona fide apprenticeship program. Bona fide programs are those that have been registered with DOL, Employment and Training Administration, Office of Apprenticeship, or with a DOL-recognized State Apprenticeship Agency (SAA). (Note that an SAA must also partner with a State Apprenticeship Council (SAC). The SAC must consist of an equal number of representatives of employer and employee organizations.)

#### d. Prevailing wages or wage rates

Davis-Bacon prevailing wage rates generally appear as a basic hourly rate plus fringe benefits, if any. “Prevailing wage” is made up of two interchangeable components: the basic hourly wage, and fringe benefits. The total of the basic hourly wage and fringe benefits comprises the “prevailing wage” obligation. This obligation may be met by any combination of cash wages and creditable “bona fide” fringe benefits provided by the employer.

#### e. Overtime

Overtime (O/T) hours are defined as all hours worked in excess of 40 hours in any workweek. Where governed by Federal labor standards, O/T hours shall be compensated at not less than one and one-half times the regular rate of basic pay plus the straight-time (S/T) rate of any required fringe benefits.

#### f. Site of work

The “site of work” is limited to the physical place or places where the construction called for in the contract will remain when work on it has been completed. “Site of work” includes other adjacent or nearby properties used by the contractor/subcontractor in the construction of the project (e.g., fabrication sites) provided they are dedicated exclusively or nearly so to the performance of the contract or project, and are so located in proximity to the actual construction location that it would be reasonable to include them.

#### g. Proper designation of trade

Each laborer and mechanic shall be classified in accordance with the work classifications listed on the wage decision and the actual type of work they perform and shall be paid the appropriate wage rate and fringe benefits for the classification regardless of their level of skill. In other words, if someone is performing carpentry work on the project, they must be paid no less than the wage rate on the wage decision for carpenters even if they aren’t considered by the employer to be fully trained as a carpenter. The only people who can be paid less than the rate for their craft are apprentices and trainees registered in approved programs.

**h. Split classification**

Laborers and mechanics that perform work in more than one classification may be compensated at the rate specified for each classification provided that the employer maintains time records that accurately set forth the time spent in each classification in which the work was performed. If accurate time records are not maintained, the employee shall be compensated at the highest of all wage rates for the classifications in which work was performed.

## B - SECTION

### GREENBRIDGE APT. BUILDINGS A, B & C WALKWAY REPAIRS

99155 7<sup>TH</sup> AVE., SEATTLE, WA. 98106

**DUE DATE:** May 27, 2026

**TIME:** 11:00AM

In order to be considered as **RESPONSIVE BIDS**, all bidders **MUST** submit the following **Signed Documents (each single sided)** no later than the **Bid Due Date and Time**.

### Forms to Return if Bidding

- B.1 Bid Form**
- B.2 Bidder's Experience Record**
- B.3 Contractor Certification**
- B.4 Non-Collusive Affidavit**
- B.5 Equal Opportunity**
- B.6 Bid Security (Submit only for bids greater than \$150,000)**
- B.7 Debarment / Suspension Compliance Certification**
- B.8 Proposed Subcontractor List**
- B.9 Section 3**
  - a. Business Certification**
  - b. Subcontractor Work Plan**
- B.10 Harassment and Discrimination Policies**
- B.11 WMBE Survey (Form is not required to be responsive, but requested)**
- B.12 Preliminary Project Schedule – Provided by Contractor**



# BID FORM – RETURN EACH FORM SINGLE SIDED

**BID TO:**

KING COUNTY HOUSING AUTHORITY  
ASSET MANAGEMENT DEPARTMENT  
600 Andover Park West, Tukwila, WA 98188

**PROJECT NAME AND LOCATION:**

Greenbridge Apt. Buildings A, B & C Walkway Repairs  
9915 7<sup>th</sup> Ave. Seattle, WA. 98106

**SCOPE OF WORK:**

Work includes, but is not limited to, structural repairs to elevated walkway at the fully occupied buildings A, B and C. Contract scope includes removing and re-installation of existing metal railings at walkways as needed to perform repairs while ensuring safety measures are in place to maintain resident access. The contractor is to remove soffits and deck sheathing as required to perform structural work on walkways. The contractor is to remove walkway support post and knee braces and replace with steel framing utilizing existing knife plates for connections. Replace walkway edge wood beams.

**For complete scope, please see E.1 Scope of Work and Technical Specifications**

**BASE BID:**

Bidders must provide a cost for **each and every** bid item (even if the amount is **\$0.00**), for the bid to be considered responsive. Where conflict occurs between the bid item values entered and the total amount written, the bid item price(s) shall prevail, and totals will be corrected to conform thereto. The work of the various items is described throughout the Contract Documents.

**Total Base Bid Lump Sum Amount (Gross Contract Price)** should include all applicable taxes. King County Housing Authority (KCHA) will only pay this Gross Contract Price. Contractors shall review the State of Washington Department of Revenue Ruling WAC 458-20-17001 (included in bid documents) and all other applicable documents for tax obligations.

**Contractor must pay the attached  Davis Bacon /  Non-Routine Maintenance** as the Minimum Wages and Fringe Benefits for the construction workers under this contract.

**The Bidder agrees to accept as full payment for the Work**, as specified in the Contract Documents, and based upon the undersigned’s own estimate of quantities and costs, the following stipulated sums.

**Owner Allowance** is a designated sum of funds to be included in estimate to cover unforeseen conditions, such as undiscovered wood rot or erosion, microbial growth, hazardous materials, etc. The total amount will require standard backup submitted for change order claims. COP must be submitted prior to any work being performed. Contractor to clearly identify conditions requiring funds and provide paystubs, and receipts for material and equipment as well as any invoices from service providers.

BASE BID PRICE		
<b>A.</b>	<b>Materials</b> , including all applicable <b>Taxes</b>	<b>\$</b>
<b>B.</b>	<b>Labor</b>	<b>\$</b>
<b>C.</b>	<b>O &amp; P</b> , including all applicable <b>Fees</b>	<b>\$</b>

Bidding Contractor’s Company Name: \_\_\_\_\_ Initials: \_\_\_\_\_



<b>D.</b>	Owner Allowance for added work contingency, as authorized by KCHA	<b>\$86,000</b>
<b>TOTAL BID AMOUNT: (all costs inclusive – A, B, C&amp; D) Round to Nearest Dollar</b>		<b>\$</b>
		<b>And No/100 Dollars</b>
<b>PRINT (in words) Total Bid Amount. <i>Sample – Three Hundred Thousand, Two Hundred Sixty-Six</i></b>		

**UNIT PRICES:**

Unit prices are considered for use when small quantities are needed and additional competitive bidding is not required for price justification. An unforeseen condition requiring large quantities resulting in a substantial change in scope of new work will not be considered applicable for unit pricing. Large deviations in the scope of work will be addressed and evaluated through a bid process or on a Time Material basis as stipulated in the contract documents. Acceptance of any unit pricing is at the Owner’s discretion.

**COMPLETE BID:**

Contractor shall include all costs of doing the work shown, described, and intended by the Contract Documents, within the lump sum bid prices in the Proposal.

**LOW BIDDER DETERMINATION:**

The determination of the Low Bidder will be determined on the basis of the Grand Total of the Total Base Bid Price plus Owner-Directed Work Total. The Owner reserves the right to accept any, all, or no Additive items at the time of Award, or at any time thereafter.

**RIGHT TO AWARD THE CONTRACT:**

KCHA reserves the right to award the Contract to the Contractor based on the Contractor’s Qualifications, Bonding Capacity and ability to Complete the Project within the Completion Time allowed for project. If written notice of the acceptance of this bid is mailed, or delivered to the undersigned within Seven (7) days after the opening thereof, or at any time thereafter before this bid is withdrawn, the undersigned agrees to execute and deliver a Contract in the prescribed form within Seven (7) calendar days after the Contract is presented for signature.

**RIGHT TO REJECT BIDS:**

KCHA Reserves the Right to Reject any and all Bids and select any bid options (Base Bid/Alternate Bid or both). In addition, KCHA Reserves the Right to Refuse to Award a Bid to a Contractor based on the Contractor’s Past Performance, and/or Unresolved Issues with KCHA, as well as unresolved issues with Washington State Labor & Industries. No Extension of Completion is allowed.

KCHA also Reserves the Right to Reject all bids, for any reason, prior to Contract Execution.

The undersigned hereby agrees that this proposal shall be a Valid and Firm Offer for the following calendar days from the date of the Bid Opening.

**Calendar Days: SIXTY (60)**

Bidding Contractor’s Company Name: \_\_\_\_\_ Initials: \_\_\_\_\_



If the Contractor’s Bid is determined to be “Not Responsible”, KCHA will issue in writing the specific reasons for this determination. Your company will be allowed to appeal this decision. The appeal must be in writing. The appeal must be delivered to KCHA at the address provided in the determination of ‘Not Responsible’ within two (2) business days after KCHA makes the decision. The appeal may include additional information that was not included in the original Bid Documents. KCHA will make a final determination after the receipt of the appeal. The final determination may not be appealed.

**ADDENDUM RECEIPT: (Receipt of the following Addenda is acknowledged)**

Addendum No.: \_\_\_\_\_ Date: \_\_\_\_\_  
Addendum No.: \_\_\_\_\_ Date: \_\_\_\_\_  
Addendum No.: \_\_\_\_\_ Date: \_\_\_\_\_  
Addendum No.: \_\_\_\_\_ Date: \_\_\_\_\_

NO ADDENDA were received

**START TIME OF CONSTRUCTION:**

Construction for the project must be started in accordance with the written Notice to Proceed Date issued by KCHA.

**COMPLETION TIME OF CONSTRUCTION:**

The undersigned hereby agrees to significantly complete the project within the construction period or duration (**Construction Period/Duration: NTP “construction start” to physical completion**) all the work required under the Contract and in accordance with the Contract Documents. Time allowed to complete the project (including punch list items) shall be the following number of Calendar Days from the Notice to Proceed Date issued by KCHA:

**Calendar Days: One hundred twenty (120)\***

*\* This is total construction time and does not include any delays that may be caused by supply chain issues.*

**PRELIMINARY SCHEDULE:**

**MANDATORY:** Contractor is to **provide** a preliminary Master Project Schedule in Microsoft Project, Primavera or similar and will include task durations and a project duration/completion date **at time of bid.**

**METHOD OF PAYMENT:**

Contract Amount shall be paid by KCHA to the Contractor monthly from the date of Contract, based on Contractor’s Invoice of percentage of ‘Completion’. Contractor shall use the AIA-G702 and G703 forms for Application and Certificate for Payment for Invoice Submittal.

**CONTRACT RETENTION:**

KCHA will withhold Contract Retention at the following Rate, pursuant to the General Conditions and will be released upon receipt of the Proper clearances from all pertinent state agencies. Release of Retention will not be made until All Requirements for Release, including clearances from State Agencies are received.

**Retention Rate: FIVE PERCENT (5%)**

**CLOSEOUT PERCENTAGE:**

Contractor to include in his Schedule of Values **Closeout Costs**; this is a percentage of the contract bid amount for costs associated with closing out the project as described in Section 01 77 00.

Bidding Contractor’s Company Name: \_\_\_\_\_ Initials: \_\_\_\_\_

**Closeout Percentage: FIVE PERCENT (5%)**

**LIQUIDATED DAMAGES:**

Timely performance and completion of the Work is essential to the Owner and time limits stated in the Agreement are of the essence. Owner will incur serious and substantial damages if Substantial Completion of the Work or Contract Completion of the entire project does not occur in the time limits defined in the Contract or subsequent change order. Liquidated damages are not assessed as a penalty, but as liquidated damages for breach of contract. The amount is fixed and agreed upon by the Contractor and Owner due to the extreme difficulty and impracticability of fixing and ascertaining the actual damages the Owner would sustain.

This amount is construed as actual amount of damages to the Owner and may be retained by the Owner and deducted from any payments to the Contractor. Assessment of liquidated damages does not release the Contractor for obligations in the Agreement. If different and separate completion dates are stated in the Agreement (or subsequent change order) for separate parts or stages of the Work, the amount of liquidated damages shall apply and may be assessed on those parts or stages of the Work which are delays.

If the Contractor fails to complete the Work by the Time for Substantial Completion stated above (or amended by a subsequent change order), then the Contractor agrees to abide by all provision of the Liquidated Damages clause to the Contract. Liquidated Damages shall be in the following DOLLAR AMOUNT per Calendar Days and will be assessed for each day that the Contractor exceeds the time for substantial completion stated above as follows:

**Dollar Amount: FIFTEEN HUNDRED DOLLARS AND NO/100 (\$1500.00)**

**INDEMNIFICATION AND HOLD HARMLESS:**

The Contractor hereby agrees that, to the fullest extent permitted by law, it will defend, indemnify and hold KCHA and its officials, partners, volunteers, agents and employees (the “Indemnities”) harmless from and against any and all claims, losses, damages and expenses, including attorney’s fees incurred with respect thereto or in enforcing this indemnity, which in any manner arise out of or in connection with, or result from:

1. The Work to be performed pursuant to this contract (the ‘Work’), or
2. Any Act or Omission of:
  - a. The Contractor;
  - b. Any Subcontractor, Lower Tier Contractor, or Supplier engaged with respect to the Work;
  - c. Any other party acting at the direction, at the request or under the control of the Contractor with respect to this contract or the Work; or
  - d. The Officers, Directors, Partners, Employees, Volunteers or Agents of any of the foregoing, or the successors in interest of any of them.

Notwithstanding the foregoing, however, the Contractor shall not be required to indemnify and Indemnitee against liability for damages arising out of bodily injury to persons or damage to property caused by or resulting from the intentional misconduct or sole negligence of the Indemnitee, and if such damages are caused by or result from the concurrent negligence of the Indemnitee and the Contractor or its employees or agents, then the Contractor’s indemnity hereunder shall be limited to the extent of the negligence of the Contractor or its employees or agents. For purposes of this Indemnity, the Contractor waives its immunity under industrial insurance, Title 51 of the Revised Code of Washington, and acknowledges that the parties have negotiated this waiver for the purposes of this agreement.

Bidding Contractor’s Company Name: \_\_\_\_\_ Initials: \_\_\_\_\_



The Contractor hereby agrees to require all its Subcontractors or anyone acting under its direction or control or on its behalf in connection with or incidental to the performance of this contract to execute an indemnity agreement substantively identical to the proceeding one, specifically naming KCHA as an indemnitee, and the Contractor’s failure to do so shall constitute a material breach of this contract by the Contractor.

**LOCAL RESIDENCE HIRING AND CONTRACTING REQUIREMENTS FOR SECTION 3:**

The undersigned agrees to adhere to the Local Resident Hiring and Contracting Requirements as defined in the Section 3 Documents. Failure to comply with this program “to the greatest extent feasible” may result in the withholding of progress payments until the breach of the contract is remedied. See Section 3 Certification Forms attached.

I certify, under penalty of perjury, that my company  Is a Section 3 Business

Is Not a Section 3 Business

(For further clarification for Section 3 Certification, refer to Sections A.8 and B.10.a)

**BID WITHDRAWAL AFTER BID OPENING:**

1. A bidder who submits an erroneous low bid may withdraw the bid at the risk of forfeiting the bid bond. The bid withdrawal is permissible if there was an obvious error in the low bid and the mistake is readily apparent from the bid itself. The bidder must notify KCHA and submit evidence of the error within twenty-four (24) hours of the bid opening.
2. Evaluating factors for return or forfeiture of bid bonds should include:
  - a. Whether the bidder acted in good faith;
  - b. Whether the bidder acted without gross negligence;
  - c. Whether the bidder gave prompt notice of the error;
  - d. Whether the bidder will suffer substantial detriment by forfeiture;
  - e. Whether KCHA’s status has not greatly changed, and no substantial hardship will be caused.
3. Any low bidder who withdraws its bid is prohibited from bidding on the same project if it is subsequently re-solicited.

**NOTIFICATION:**

Contractors submitting bids must have current industrial insurance and not be disqualified from bidding (not suspended or debarred by any federal, state, or other public agency).

All or a portion of this contract is paid for by Federal Funds. As a result, Successful Contractors are subject to the following statutes: Section 504 of the Rehabilitation Act of 1973; the Americans with Disabilities Act of 1990; the Architectural Barriers Act of 1968 and the Fair Housing Act of 1988.

It will be the Contractor’s obligation to comply with pertinent laws and implementing regulations, which provide for non-discrimination and accessibility in Federally Funded Housing and Non-Housing Programs for people with Disabilities. To read the full text of the Notice go to [www.kcha.org/business/requirements](http://www.kcha.org/business/requirements). Scroll down to Fair Housing Laws and Read: **Fair Housing / Accessibility Notice**

Bidding Contractor’s Company Name: \_\_\_\_\_ Initials: \_\_\_\_\_

**The undersigned acknowledges:**

1. To have carefully reviewed and understood the scope of work and requirements under the Contract Documents and the complete scope of work as required under the Bid Proposal,
2. To have been provided the opportunity to physically assess the project site,
3. And affirms that the bid entered herein, shall be a complete bid in accordance with the terms of the Contract Documents,
4. That no person or company was employed or retained to solicit or obtain this contract and no payment of, or agreement to pay any person or company to solicit or obtain this contract any commission, percentage, brokerage, or other fee contingent upon or resulting from the award of this contract.
  - a. Should any misrepresentation of the bidder be found, KCHA will have the right to 1) terminate the contract; 2) at its discretion, deduct from the contract payment amounts the amount of any commission, percentage, brokerage, or other contingent fee; or 3) any other remedy pursuant to the contract.
5. And hereby agrees to complete the Work required under the terms of the Contract Documents by the Completion Dates enumerated therein, and
6. That all Documents Submitted to KCHA will become Public Records, as per RCW 42.56. If you are submitting information, which you think is confidential and / or proprietary to your business; KCHA recommends that you do not submit that information, as KCHA cannot guarantee that type of information will be withheld from a public disclosure request.

Bidding Contractor's Company Name: \_\_\_\_\_ Initials: \_\_\_\_\_



**COMPANY INFORMATION** *(please print all information):*

**Name of Bidder’s Company** \_\_\_\_\_

**Physical Street Address:**  
**(Contractor MUST have a Physical Street Address)** \_\_\_\_\_

City-State-Zip: \_\_\_\_\_

Mailing Address if different than Physical: \_\_\_\_\_

City-State-Zip: \_\_\_\_\_

Telephone: \_\_\_\_\_

Name of Person Authorized to Sign Contract:  
*(if Company is Awarded Contract)* \_\_\_\_\_

Title of Person Authorized to Sign Contract:  
*(if Company is Awarded Contract)* \_\_\_\_\_

Email Address of Person Authorized to Sign Contract:  
*(if Company is Awarded Contract)* \_\_\_\_\_

Website: \_\_\_\_\_

Contractor’s License (WA State) Number: \_\_\_\_\_

UBI (Unified Business License) Number: \_\_\_\_\_

Employment Security Account Number: \_\_\_\_\_

State Excise Tax Registration Number: \_\_\_\_\_

Federal Tax I.D. Number: \_\_\_\_\_

Exempt

Public Works Training (RCW39.04.350):  Not Exempt – signed Compliance Statement in Accordance with RCW 9A.72.085 is provided

Bidding Contractor’s Company Name: \_\_\_\_\_ Initials: \_\_\_\_\_



KCHA – GREENBRIDGE APT. BUILDING A, B & C WALKWAY REPAIRS  
ASSET MANAGEMENT DEPARTMENT

- Check Box if your company is a Corporation and name the State Incorporated in below.
- Check Box if your company is a Partnership and provide Full Name(s) and Address of all parties below.
- Check Box if your company is also known as (aka) and list that name and address below.

**NOTE:** The penalty for making false statements in offer is prescribed in 18 U.S.C. 1001.

SUBMITTED ON: \_\_\_\_\_ Day of \_\_\_\_\_, 20\_\_\_\_

\_\_\_\_\_  
Signature of Bidder

\_\_\_\_\_  
Print Name and Title

Bidding Contractor’s Company Name: \_\_\_\_\_ Initials: \_\_\_\_\_



LIST THE SUPERVISORY PERSONNEL TO BE EMPLOYED BY THE BIDDER AND AVAILABLE FOR, AND INTENDED TO WORK ON THIS PROJECT (PROJECT MANAGER, PRINCIPAL FOREPERSON, SUPERINTENDENTS AND ENGINEERS): **PRINT ALL INFORMATION**

NAME	TITLE	HOW LONG WITH BIDDER
_____	_____	_____
_____	_____	_____
_____	_____	_____
_____	_____	_____

LIST ALL PUBLICLY FUNDED PROJECTS OF SIMILAR NATURE & SIZE COMPLETED BY BIDDER WITHIN THE PAST 5 YEARS. INCLUDE A REFERENCE FOR EACH. IF NECESSARY, ATTACH A SEPARATE SHEET(S), USING THE FORMAT BELOW. **PRINT ALL INFORMATION**

**PROJECT NAME:** \_\_\_\_\_  
**OWNER/CONTACT NAME & NUMBER:** \_\_\_\_\_  
**TOTAL CONTRACT AMOUNT:** \_\_\_\_\_  
**IF SUB, YOUR CONTRACT AMOUNT:** \_\_\_\_\_  
**YEAR PROJECT COMPLETED:** \_\_\_\_\_

**PROJECT NAME:** \_\_\_\_\_  
**OWNER/CONTACT NAME & NUMBER:** \_\_\_\_\_  
**TOTAL CONTRACT AMOUNT:** \_\_\_\_\_  
**IF SUB, YOUR CONTRACT AMOUNT:** \_\_\_\_\_  
**YEAR PROJECT COMPLETED:** \_\_\_\_\_

**PROJECT NAME:** \_\_\_\_\_  
**OWNER/CONTACT NAME & NUMBER:** \_\_\_\_\_  
**TOTAL CONTRACT AMOUNT:** \_\_\_\_\_  
**IF SUB, YOUR CONTRACT AMOUNT:** \_\_\_\_\_  
**YEAR PROJECT COMPLETED:** \_\_\_\_\_

**PROJECT NAME:** \_\_\_\_\_  
**OWNER/CONTACT NAME & NUMBER:** \_\_\_\_\_  
**TOTAL CONTRACT AMOUNT:** \_\_\_\_\_  
**IF SUB, YOUR CONTRACT AMOUNT:** \_\_\_\_\_  
**YEAR PROJECT COMPLETED:** \_\_\_\_\_



IF ANY OF THE PROJECTS LISTED ABOVE WERE NOT COMPLETED WITHIN THEIR ORIGINALLY SCHEDULED PERIOD, EXPLAIN WHY: **PRINT ALL INFORMATION**

---

---

---

---

---

LIST ALL PROJECTS UNDERTAKEN IN THE LAST 5 YEARS WHICH HAVE RESULTED IN PARTIAL OR FINAL SETTLEMENT OF THE CONTRACT BY ARBITRATION OR LITIGATION IN THE COURTS: **PRINT ALL INFORMATION**

<u>NAME OF CLIENT &amp; PROJECT</u>	<u>CONTRACT AMT.</u>	<u>TOTAL CLAIM ARBITRATED / LITIGATED</u>	<u>AMT. OF SETTLEMENTS OF CLAIM</u>
<hr/>	<hr/>	<hr/>	<hr/>
<hr/>	<hr/>	<hr/>	<hr/>
<hr/>	<hr/>	<hr/>	<hr/>
<hr/>	<hr/>	<hr/>	<hr/>
<hr/>	<hr/>	<hr/>	<hr/>

HAS BIDDER, OR ANY REPRESENTATIVE OR PARTNER THEREOF, EVER FAILED TO COMPLETE A CONTRACT? **PRINT ALL INFORMATION**

NO      YES      IF YES, EXPLAIN \_\_\_\_\_

HAS THE BIDDER EVER HAD ANY PAYMENT / PERFORMANCE BOND CALLED AS A RESULT OF THIS WORK? **PRINT ALL INFORMATION**

NO      YES *IF YES, COMPLETE THE FOLLOWING:*

<u>PROJECT NAME</u>	<u>CONTRACTING PARTY</u>	<u>BOND AMOUNT</u>
<hr/>	<hr/>	<hr/>
<hr/>	<hr/>	<hr/>

HAS BIDDER EVER BEEN FOUND GUILTY OF VIOLATING ANY STATE OR FEDERAL EMPLOYMENT LAWS? **PRINT ALL INFORMATION**

NO      YES      IF YES, EXPLAIN \_\_\_\_\_

HAS BIDDER EVER FILED FOR PROTECTION UNDER ANY PROVISION OF THE FEDERAL BANKRUPTCY LAWS OR STATE INSOLVENCY LAWS? **PRINT ALL INFORMATION**

NO      YES      IF YES, EXPLAIN \_\_\_\_\_



HAS ANY ADVERSE LEGAL JUDGEMENT RELATED TO CONSTRUCTION BEEN RENDERED AGAINST THE BIDDER IN THE LATE 5 YEARS? **PRINT ALL INFORMATION**

NO YES IF YES, EXPLAIN \_\_\_\_\_

HAS BIDDER OR ANY OF ITS EMPLOYEES FILED ANY CLAIMS WITH WASHINGTON STATE WORKER'S COMPENSATION OR OTHER INSURANCE COMPANY FOR ACCIDENTS RESULTING IN FATAL INJURY OR DISMEMBERMENT IN THE PAST 5 YEARS? **PRINT ALL INFORMATION**

NO YES IF YES, COMPLETE THE FOLLOWING:

DATE	TYPE OF INJURY	AGENCY RECEIVING CLAIM
_____	_____	_____
_____	_____	_____
_____	_____	_____

BIDDER'S EXPERIENCE MODIFICATION RATE (EMR): 2023 \_\_\_\_\_ 2024 \_\_\_\_\_ 2025 \_\_\_\_\_  
(IF BIDDER IS SELF-INSURED, ATTACH PROOF OF EMR STATED, SHOWING COMPLETE WORKSHEET CALCULATIONS)

**NOTES TO BIDDERS: SAFETY IS A PRIMARY CONCERN ON THIS PROJECT.** KCHA reserves the right to disqualify Bidders where either the current or three (3) year average of the Experience Modification Rate (EMR) EXCEEDS 1.0. KCHA may require additional information from Bidders that have an EMR of more than 1.0.

DESCRIBE ALL VIOLATION CITATIONS ISSUED AGAINST BIDDER IN THE LAST 5 YEARS UNDER OSHA, WISHA OR OTHER APPLICABLE WORKPLACE SAFETY PROGRAMS. **PRINT ALL INFORMATION**

SUBJECT OF VIOLATION	DATE OF INSPECTION / INCIDENT	OSHA ACTIVITY NO.	CLOSED / PENDING
_____	_____	_____	_____
_____	_____	_____	_____
_____	_____	_____	_____
_____	_____	_____	_____

**ADDITIONAL INFORMATION:**

BEFORE A BID IS CONSIDERED FOR AWARD, THE BIDDER MAY BE REQUESTED BY KCHA TO SUBMIT A STATEMENT OR OTHER DOCUMENTATION REGARDING ANY OF THE BASIC QUALIFICATIONS LISTED ABOVE. FAILURE BY THE BIDDER TO PROVIDE SUCH ADDITIONAL INFORMATION SHALL RENDER THE BIDDER NON-RESPONSIVE AND NON-RESPONSIBLE, AND INELIGIBLE FOR AWARD.

THE UNDERSIGNED WARRANTS UNDER PENALTY OF PERJURY THAT THE FOREGOING INFORMATION IS COMPLETE, TRUE AND ACCURATE TO THE BEST OF HIS / HER KNOWLEDGE. THE UNDERSIGNED AUTHORIZES THE KING COUNTY HOUSING AUTHORITY TO VERIFY ALL INFORMATION CONTAINED HEREIN. (IF THIS INFORMATION IS NOT COMPLETE AND ACCURATE THE BID MAY BE CONSIDERED NON-RESPONSIVE.)

\_\_\_\_\_  
BIDDER'S SIGNATURE BIDDER'S NAME (PLEASE PRINT)

\_\_\_\_\_  
BIDDER'S TITLE (PLEASE PRINT) DATE

**CONTRACTOR CERTIFICATION – RETURN EACH FORM SINGLE SIDED**

**PROJECT NAME: GREENBRIDGE APT. BILDINGS A, B & C WALKWAY REPAIRS**

NAME OF COMPANY: \_\_\_\_\_

PHYSICAL STREET ADDRESS: \_\_\_\_\_

CITY – STATE – ZIP: \_\_\_\_\_

MAILING ADDRESS: \_\_\_\_\_

CITY – STATE – ZIP: \_\_\_\_\_

PHONE NUMBER: \_\_\_\_\_

FEDERAL TAX ID NO.: \_\_\_\_\_ WA STATE UBI NO.: \_\_\_\_\_

TYPE OF BUSINESS: \_\_\_\_\_ CORPORATION \_\_\_\_\_ LLC - PARTNERSHIP \_\_\_\_\_ SOLE PROPRIETOR

**OWNERS OF THIS COMPANY** (List All Owners from the inception of the Company. Use an additional sheet of paper if necessary.)

NAME OF OWNER(S)	DATE(S) OF OWNERSHIP (from – to)
_____	_____
_____	_____
_____	_____

**UNDER PENALTIES OF PERJURY,** \_\_\_\_\_ **I /** \_\_\_\_\_ **We** hereby certify that: (Check the appropriate responses)

- There are no contractual obligation or other disabilities that would prevent the achievement of the various requirements contained in the Bid Documents to the greatest extent feasible and with good faith efforts to attempt to meet the attached goals.
- \_\_\_\_\_ **I /** \_\_\_\_\_ **We** do not and will not maintain, nor permit \_\_\_\_\_ **My /** \_\_\_\_\_ **Our** employees to work in a location where segregated facilities are maintained, except for separate or single-user toilets and changing facilities, if necessary, to assure privacy between the sexes.
- Any facility used in the performance of this project \_\_\_\_\_ **Is /** \_\_\_\_\_ **Is Not** listed on the Environmental Protection Agency list of violating facilities; and,
- \_\_\_\_\_ **I /** \_\_\_\_\_ **We** will notify KCHA, PRIOR TO award, of the receipt of any communication from the Environmental Protection Agency indicating that any facility proposed to be used in the performance of this project is under consideration to be listed on the EPA List of Violating Facilities; and,
- \_\_\_\_\_ **I /** \_\_\_\_\_ **We** will include a certification substantially the same as this certification in every non-exempt contract.
- \_\_\_\_\_ **I /** \_\_\_\_\_ **We** that \_\_\_\_\_ **Have /** \_\_\_\_\_ **Have Not** participated in an Equal Employment Opportunity Plan in the past that required filing reports with the Government; and that if \_\_\_\_\_ **I /** \_\_\_\_\_ **We** have, \_\_\_\_\_ **I /** \_\_\_\_\_ **We** \_\_\_\_\_ **Have /** \_\_\_\_\_ **Have Not** filed all reports due. If not, the reports will be filed within the next (\_\_\_\_\_) days.

7. The number shown on this form is the correct Taxpayer Identification Number OR if no Taxpayer Identification Number is listed, a notarized explanation as to why is attached to these Bid Documents and

8. \_\_\_\_\_ I / \_\_\_\_\_ We further certify that \_\_\_\_\_ I / \_\_\_\_\_ We are **not** subject to Backup Withholding because;

\_\_\_\_\_ Exempt from Backup Withholding, or  
\_\_\_\_\_ No notification from the Internal Revenue Service (IRS) for failing to report all interest or  
\_\_\_\_\_ dividends, or

\_\_\_\_\_ No long subject to Backup Withholding per notification from the IRS  
*(If you ARE subject to Backup Withholding, leave \$5 blank and go to #6)*

9. \_\_\_\_\_ I / \_\_\_\_\_ We have been notified by the IRS that \_\_\_\_\_ I Am / \_\_\_\_\_ We Are currently subject to Backup Withholding because of under reporting interest or dividends.  
**(If you filled out #5 – you are NOT subject to Backup Withholding, leave #6 blank)**

\_\_\_\_\_, who is by title the \_\_\_\_\_  
of our firm/company and has been designated, as the responsible official to ensure required reports are submitted, and record keeping complies with all the applicable regulations.

**AUTHORIZED OFFICIAL:**

\_\_\_\_\_  
SIGNATURE

\_\_\_\_\_  
NAME (PLEASE PRINT)

\_\_\_\_\_  
TITLE (PLEASE PRINT)

\_\_\_\_\_  
DATE





**EQUAL OPPORTUNITY CLAUSE – RETURN EACH FORM SINGLE SIDED**

DURING THE PERFORMANCE OF THIS CONTRACT, THE CONTRACTOR AGREES AS FOLLOWS:

1. The Contractor will not discriminate against any employee or applicant for employment because of race, color, religion, sex, or national origin, citizenship status, creed, age, marital status, physical or mental disability, sexual orientation, political ideology, or status as a Vietnam era or specially disabled veteran. The Contractor will take affirmative action to ensure that applicants are employed and the employees are treated during employment without regard to the aforementioned conditions. Such action shall include, but not be limited to, the following: Employment, upgrading, demotion, or transfer; recruitment or recruitment advertising; layoff or termination; rates of pay or other forms of compensation; and selection for training, including apprenticeship. The Contractor agrees to post in conspicuous places, available to employees and applicants for employment, notices to be provided by the Contracting Officer setting forth the provisions of this nondiscrimination clause.
2. The Contractor will, in all solicitations or advertisements for employees placed by or on behalf of the Contractor, state that all qualified applicants will receive consideration for employment without regard to the aforementioned conditions of paragraph 1 above.
3. The Contractor will send to each labor union or representative of workers with which he/she has a collective bargaining agreement or other contract or understanding, a notice advising the labor union or workers' representative of the Contractor's commitments under Section 202 of Executive Order 11246 of September 24, 1965, and shall post copies of the notice in conspicuous places available to employees and applicants for employment.
4. The Contractor will comply with all provisions of Executive Order 11246 of September 24, 1965, and of the rules, regulations and relevant orders of the Secretary of Labor.
5. The Contractor will furnish all information and reports required by Executive Order 11246 of September 24, 1965, and by the rules, regulations and relevant orders of the Secretary of Labor, or pursuant thereto, and will permit access to his/her books, records and accounts by the Owner and the Secretary of Labor for purposes of investigation to ascertain compliance with such rules, regulations and orders.
6. In the event of the Contractor's non-compliance with the non-discrimination clauses of the Contract or with any of such rules, regulations or orders, this Contract may be canceled, terminated or suspended in whole or in part and the Contractor may be declared ineligible for further Government Contracts, in accordance with procedures authorized in Executive Order 11246 of September 24, 1965, and such other sanctions may be imposed and remedies invoked as provided in Executive Order 11246 of September 24, 1965, or by rules, regulation, or order of the Secretary of Labor, or as otherwise provided by law.
7. The Contractor will include the provisions of paragraphs (1) through (7) in every subcontract or purchase order unless exempted by rules, regulation, or order of the Secretary of Labor issued pursuant to Section 204 of Executive Order 11246 of September 24, 1965, so that such provisions will be binding upon each subcontractor or vendor. The Contractor will take such action with respect to any subcontract or purchase order as the Owner may direct as a means of enforcing such provisions including sanctions for noncompliance: Provided, however, that in the event the Contractor becomes involved in, or is threatened with, litigation with a subcontractor or vendor as a result of such direction by the Owner, the Contractor may request the United States to enter into such litigation to protect the interests of the United States.

**AUTHORIZED OFFICIAL:**

\_\_\_\_\_  
SIGNATURE

\_\_\_\_\_  
NAME (PLEASE PRINT)

\_\_\_\_\_  
TITLE (PLEASE PRINT)

\_\_\_\_\_  
DATE

Bidding Contractor's Company Name: \_\_\_\_\_ Initials: \_\_\_\_\_



**BID SECURITY – RETURN EACH FORM SINGLE SIDED**

**BID DEPOSIT:**

The undersigned Principal hereby deposits a Bid Deposit with the King County Housing Authority in the form of a cash deposit, certified or cashier's check, or postal money order in the amount of:

\_\_\_\_\_ Dollars (\$ \_\_\_\_\_)

-- OR --

**BID BOND:**

The undersigned, \_\_\_\_\_ (Principal), and

\_\_\_\_\_ (Surety), are held and firmly bound unto the King County Housing Authority (Owner) in the penal sum of:

\_\_\_\_\_ Dollars (\$ \_\_\_\_\_),

which for the payment of which Principal and Surety bind themselves, their heirs, executors, administrators, successors and assigns, jointly and severally. The liability of surety under this Bid Bond shall be limited to the penal sum of this Bid Bond.

**CONDITIONS:**

The Bid Deposit or Bid Bond shall be an amount not less than **five percent (5%)** of the total bid, including any Alternates, Additives, and Owner-Directed Work, if any, including sales tax, if any, and is submitted by Principal to Owner in connection with a Proposal in according to the terms of the Proposal and Bid Documents for:

**GREENBRIDGE APT. BUILDINGS A, B & C WALKWAY REPAIRS**

**NOW THEREFORE:**

- a. If Principal requests, in writing, to withdraw its Bid, prior to Bid Opening, or
- b. If the Proposal is rejected by Owner, or
- c. Owner in accordance with the terms of the Proposal and furnishes a bond for the faithful performance of said Project and for the payment of all persons performing labor or furnishing materials in connection therewith, with Surety or Sureties approved by Owner,

then this Bid Security shall be released; otherwise it shall remain in full force and effect and Principal shall forfeit the Bid Deposit or Surety shall immediately pay and forfeit to Owner the amount of the Bid Bond, as penalty and liquidated damages.

The obligations of Surety and its Bid Bond shall be in no way impaired or affected by any extension of time within which Owner may accept bids; and Surety does hereby waive notice of any such extension.

Bidding Contractor's Company Name: \_\_\_\_\_ Initials: \_\_\_\_\_



SIGNED AND DATED THIS \_\_\_\_\_ Day of \_\_\_\_\_, 20 \_\_\_\_\_.

**ATTEST to Principal’s Signature:**

\_\_\_\_\_  
PRINCIPAL (Print Company Name)

\_\_\_\_\_  
Signature of Authorized Official

\_\_\_\_\_  
Printed Name

\_\_\_\_\_  
Title (Please Print)

Corporate Seal (if Applicable)

\_\_\_\_\_  
Signature

\_\_\_\_\_  
Printed Name

\_\_\_\_\_  
Title (Please Print)

**ATTEST to Surety’s Signature:**

\_\_\_\_\_  
SURETY (Print Company Name)

\_\_\_\_\_  
Signature of Authorized Official

\_\_\_\_\_  
Printed Name

\_\_\_\_\_  
Title (Please Print)

Corporate Seal (if Applicable)

\_\_\_\_\_  
Signature

\_\_\_\_\_  
Printed Name

\_\_\_\_\_  
Title (Please Print)

The above is Attorney in Fact:

Yes                      No  
**(If Yes, attach Power of Attorney)**

**Local Office of Agent and / or Surety Company (please print):**

Name: \_\_\_\_\_

Street Address: \_\_\_\_\_

City, State, Zip: \_\_\_\_\_

Power of Attorney of person signing for Surety Company must be attached to this Bond Form.

Surety Companies executing Bonds must appear on the current Authorized Insurance List in the State of Washington.

Bidding Contractor’s Company Name: \_\_\_\_\_ Initials: \_\_\_\_\_

**DEBARMENT / SUSPENSION COMPLIANCE CERTIFICATION**  
**RETURN EACH FORM SINGLE SIDED**

The Bidder certifies to the best of its knowledge and belief, that it and its principals:

1. Are not presently debarred, suspended, proposed for debarment, declared ineligible, or voluntarily excluded from covered transactions by any federal department or agency;
2. Have not within a three (3) -year period preceding this proposal been convicted of or had a civil judgment rendered against them for commission of fraud or a criminal offense in connection with obtaining, attempting to obtain, or performing a public (federal, state or local) transaction or contract under a public transaction; violation of federal or state antitrust statutes or commission of embezzlement, theft, forgery, bribery, falsification or destruction of records, making false statements, or receiving stolen property;
3. Are not presently indicted for or otherwise criminally or civilly charged by a governmental entity (federal, state, or local) with commission of any of the offenses enumerated in paragraph (2) of this certification; and
4. Have not within a three-year period preceding this application/proposal had one or more public transactions (federal, state or local) terminated for cause or default.

**BIDDING COMPANY**

---

Company Name

---

Physical Street Address

---

City / State / Zip

---

Print Name of Authorized Official

---

Title

---

Signature of Authorized Official

---

Date**SUBSCRIBED AND SWORN to before me:**

this \_\_\_\_\_ day of \_\_\_\_\_, 20 \_\_\_\_

---

(Signature)

---

(Print Name)

My Commission Expires: \_\_\_\_\_, 20 \_\_\_\_

Bidding Contractor's Company Name: \_\_\_\_\_ Initials: \_\_\_\_\_



**SUBCONTRACTOR – FIRST TIER – LISTING – RETURN EACH FORM SINGLE SIDED**

NAME OF BIDDING COMPANY: \_\_\_\_\_

PHYSICAL STREET ADDRESS: \_\_\_\_\_

CITY / STATE / ZIP: \_\_\_\_\_

1. List Approximate Percent (%) of Work Your Company will actually Perform: \_\_\_\_\_

2. Do You Intend on using Subcontractor(s) for this Project?  Yes  No

3. **(If Yes, you must show on this form the name and information of All First Tier Subcontractors performing work that will be associated with this Bid.)** Attach additional sheets if necessary. This form needs to be completed to the best of the Bidder’s ability at time of bid. If Bidder is Awarded Contract a final subcontractor list will be submitted prior to Notice to Proceed. **PRINT ALL INFORMATION**

**SUBCONTRACTOR – FIRST TIER - LIST**

Business Name: \_\_\_\_\_ Trade: \_\_\_\_\_  
 Address: \_\_\_\_\_ Contact: \_\_\_\_\_  
 Phone: \_\_\_\_\_ Years of Experience: \_\_\_\_\_  
 UBI No.: \_\_\_\_\_

Business Name: \_\_\_\_\_ Trade: \_\_\_\_\_  
 Address: \_\_\_\_\_ Contact: \_\_\_\_\_  
 Phone: \_\_\_\_\_ Years of Experience: \_\_\_\_\_  
 UBI No.: \_\_\_\_\_

Business Name: \_\_\_\_\_ Trade: \_\_\_\_\_  
 Address: \_\_\_\_\_ Contact: \_\_\_\_\_  
 Phone: \_\_\_\_\_ Years of Experience: \_\_\_\_\_  
 UBI No.: \_\_\_\_\_

Business Name: \_\_\_\_\_ Trade: \_\_\_\_\_  
 Address: \_\_\_\_\_ Contact: \_\_\_\_\_  
 Phone: \_\_\_\_\_ Years of Experience: \_\_\_\_\_  
 UBI No.: \_\_\_\_\_

The Bidder hereby certifies that the information contained in this Proposed Subcontractor List, including any attached sheets, is accurate, complete, and current:

\_\_\_\_\_  
 Print Name of Authorized Official Title

\_\_\_\_\_  
 Signature Date

Bidding Contractor’s Company Name: \_\_\_\_\_ Initials: \_\_\_\_\_



**SECTION 3 – BUSINESS CERTIFICATION  
RETURN FORM SINGLE SIDED**

**THIS FORM MUST BE SIGNED AND RETURNED**

Project Name: \_\_\_\_\_

Company Name: \_\_\_\_\_

Address: \_\_\_\_\_

Contact Name: \_\_\_\_\_ Contact Title: \_\_\_\_\_

Contact Phone: \_\_\_\_\_ Contact Email: \_\_\_\_\_

Type of Trade or Business: \_\_\_\_\_

Current Number of Regular, Full Time Employees (Puget Sound Region): \_\_\_\_\_

1. Have over **75 percent** of the labor hours performed for your business over the prior three-month period been performed by Section 3 workers?

Yes  No **If “yes” is checked, submit the section 3 Individual Certification form(s) for all the regular, full-time employees (Puget Sound Region).**

2. Is **51% or more** of your business owned and controlled by low- or very low-income persons (persons who earn 80% or less of the median income level for the past 12 months - see attached income guidelines)?

Yes  No **If “yes” is checked, submit either the section 3 Individual Certification form(s) or the Section 3 Subcontractor Business Work Plan form.**

3. Does your business provide economic opportunities for KCHA residents at the site(s) where the work will take place?

Yes  No **If “yes” is checked, please provide supporting documentation.**

4. Does your business provide economic opportunities for residents of other KCHA developments or Section-8 assisted housing managed by KCHA?

Yes  No **If “yes” is checked, please provide supporting documentation.**

5. Does your business provide economic opportunities to Section 3 workers residing within the metropolitan area (Puget Sound Region)?

Yes  No **If “yes” is checked, please provide supporting documentation.**



**I certify, under penalty of perjury, that my company  Is  Is Not a Section 3 Business.**

I further certify that, **if my company is awarded the bid, and needs to hire additional employees for the project**, we will carry out Section 3 hiring, training and subcontracting requirements to the best of our ability.

_____ Signature	_____ Name
_____ Title	_____ Date
_____ Phone Number	_____ Email Address

If you have more specific questions about Section 3 requirements, contact KCHA at [section3@kcha.org](mailto:section3@kcha.org).

## SECTION 3 – 2025 INCOME GUIDELINES

Location	Income Limit 1 person		
	Extremely Low Income	Very Low Income	Low Income
Kitsap County (Bremerton, Silverdale)	\$26,150	\$43,550	\$69,650
King/ Snohomish Counties (Seattle, Bellevue, Everett)	\$33,050	\$55,000	\$84,850
Pierce County (Tacoma)	\$25,400	\$42,300	\$67,700
Skagit County (Sedro-Woolley)	\$23,000	\$38,250	\$61,250
Thurston County (Olympia, Tumwater)	\$24,500	\$40,850	\$65,350

## SECTION 3 – SUBCONTRACTOR WORK PLAN RETURN FORM SINGLE SIDED

RETURN THIS FORM WITH THE BID ***IF:***  
CLAIMING **YES** TO QUESTION **3** or **4** on the SECTION 3 BUSINESS CERTIFICATION FORM

Project Name: \_\_\_\_\_

Company Name: \_\_\_\_\_

Address: \_\_\_\_\_

Contact Name: \_\_\_\_\_ Contact Title: \_\_\_\_\_

Contact Phone: \_\_\_\_\_ Contact Email: \_\_\_\_\_

SECTION 3 BUSINESS CONCERN			SUBCONTRACTED TASK(S)	SUBCONTRACT AMOUNT	% OF OVERALL CONTRACT
1.	Subcontractor's Name:				
	Subcontractor's Address:				
	Subcontractor's Phone No.:				
2.	Subcontractor's Name:				
	Subcontractor's Address:				
	Subcontractor's Phone No.:				
3.	Subcontractor's Name:				
	Subcontractor's Address:				
	Subcontractor's Phone No.:				
4.	Subcontractor's Name:				
	Subcontractor's Address:				
	Subcontractor's Phone No.:				

**TOTAL CONTRACT VALUE:** \_\_\_\_\_ **TOTAL SUBCONTRACT VALUE:** \_\_\_\_\_

**PERCENTAGE OF TOTAL BID:** \_\_\_\_\_

**SUMMARY OF HARASSMENT AND DISCRIMINATION**  
**RETURN EACH FORM SINGLE SIDED**

KCHA prohibits harassment and discrimination based on race, color, national origin, citizenship status, creed, religion, sex, age, marital or veteran's status, physical or mental disability, sexual orientation, political ideology, or any other basis protected by law ("protected status"). This policy applies to KCHA's employees, vendors, contractors, visitors and others who conduct business with KCHA. The following are examples of prohibited conduct. This list is not exclusive; employees should see KCHA's Personnel Policies and Procedures for more details and vendors/contractors should contact the Human Resources Department for more details:

- Unwelcome conduct based on protected status when sufficiently severe or pervasive to create a hostile work environment; or a supervisor's improper conduct results in a tangible change in an employee's status or benefits (demotion, termination, etc.).
- Unwelcome sexual advances, requests for sexual favors and other verbal or physical conduct of a sexual nature when (1) submission to such conduct is made an implicit or explicit condition of employment; (2) submission to or rejection of such conduct affects employment opportunities or decisions; or (3) such conduct interferes with an employee's work or creates an intimidating, hostile or offensive work environment.
- Sexually suggestive or racially derogatory words, pictures, videos, cartoons, emails, etc.
- Leering, staring in a sexually suggestive manner or making offensive remarks about looks, clothing, or body.
- Touching in a way that may make an individual feel uncomfortable, such as patting, pinching or intentional brushing against another's body.
- Gestures, pictures or drawings which would offend a particular racial or ethnic group or other protected class.
- Comments about an individual's skin color, accent, or other racial/ethnic characteristics.
- Disparaging remarks or stereotypes about an individual's gender, race, birthplace, ethnicity or ancestry.
- Negative comments about an individual's religious beliefs (or lack of religious beliefs).
- Negative comments regarding an individual's age if age 40 and over.
- Derogatory or intimidating references to an employee's mental or physical impairment.

Anyone who has been harassed and/or discriminated against is expected to promptly report the alleged incident(s) to the Supervisor, Department Director, Director of Human Resources, Deputy Executive Director/Chief Administrative Officer or the Executive Director. KCHA will protect the confidentiality of such complaints to the extent possible. Complaints will be promptly, thoroughly and impartially investigated and KCHA will take immediate and appropriate corrective action when it determines that harassment has occurred. Individuals who make complaints or provide information related to complaints will be protected from retaliation.

**The Bidder hereby certifies that the information contained above is understood and agreed upon.**

Bidder's Company Name: \_\_\_\_\_

\_\_\_\_\_  
Print Name of Authorized Official

\_\_\_\_\_  
Title

\_\_\_\_\_  
Signature

\_\_\_\_\_  
Date

Bidding Contractor's Company Name: \_\_\_\_\_ Initials: \_\_\_\_\_



**WMBE SURVEY – RETURN EACH FORM SINGLE SIDED**

PLEASE COMPLETE THIS SURVEY AND RETURN WITH YOUR BID / PROPOSAL DOCUMENTS.  
**NOT SUBMITTING THIS SURVEY WILL NOT DISQUALIFY YOUR BID/PROPOSAL.**  
**THIS IS FOR INFORMATIONAL PURPOSES ONLY.**

Bidding Company Name: \_\_\_\_\_  
Address: \_\_\_\_\_  
City / State / Zip: \_\_\_\_\_

Type of Business: \_\_\_\_\_ Incorporated – Federal ID#: \_\_\_\_\_  
\_\_\_\_\_ Sole Proprietorship – SS#: \_\_\_\_\_  
\_\_\_\_\_ Other – Describe: \_\_\_\_\_

WMBE: \_\_\_\_\_ Yes \_\_\_\_\_ No

Describe: \_\_\_\_\_ Disadvantage Owned (Disabled – DBE)  
\_\_\_\_\_ Women Owned (WBE)  
\_\_\_\_\_ Minority Owned (MBE or MWBE) (Check Applicable)  
\_\_\_\_\_ 1. White American \_\_\_\_\_ 4. Hispanic American  
\_\_\_\_\_ 2. Black American \_\_\_\_\_ 5. Asian – Pacific American  
\_\_\_\_\_ 3. Native American \_\_\_\_\_ 6. Hasidic Jew

Registered WMBE: \_\_\_\_\_ Yes \_\_\_\_\_ No \_\_\_\_\_ Registration in Progress

\_\_\_\_\_  
Authorized Signer \_\_\_\_\_ Print Name and Title \_\_\_\_\_ Date \_\_\_\_\_

**FOR KCHA USE ONLY: IF THIS COMPANY HAS BEEN AWARDED THE CONTRACT, FORWARD THIS FORM**  
**TO: Michelle Jackson, Management Analyst**  
**Email: michellej@kcha.org**

Bidding Contractor's Company Name: \_\_\_\_\_ Initials: \_\_\_\_\_

**CONTRACTOR'S SUPPLIED SCHEDULE – RETURN EACH FORM SINGLE SIDED****Contractor's Preliminary/Estimated Schedule Requirements:**

- A. Gantt-Chart Schedule: Contractor to submit with their bid a fully developed, horizontal Gantt-chart-type based on the number of calendar days for the project to be completed as explained in Return Form B.1 Completion Time of Construction
- B. Preparation: Indicate each significant construction activity separately. Identify first workday of each week with a continuous vertical line.
  - 1. For construction activities that require three (3) months or longer to complete, indicate an estimated completion percentage in ten (10%) percent increments within time bar.
- C. The schedule MUST be in **Microsoft Project, Primavera or similar** software.
- D. The schedule MUST be readable (i.e. font size no less than 11pt).

NOTE: The selected Contractor will be required to submit to the Owner a Final Master Project Schedule within fourteen (14) days of date after Letter of Award. This schedule will be based on the Preliminary/Estimated Schedule and any feedback received from KCHA.

**CONTRACTOR TO INSERT  
PRELIMINARY/ESTIMATED  
PROJECT SCHEDULE HERE**

Bidding Contractor's Company Name: \_\_\_\_\_ Initials: \_\_\_\_\_

## **BB - SECTION**

### **NO PARTICIPATION for Bid Package**

#### **BB.1 No Participation Form**

# NO PARTICIPATION RESPONSE FORM

## IF YOU CHOOSE NOT TO BID ON THIS PROJECT

**RETURN ONLY THIS FORM PRIOR TO THE BID DUE DATE.**

**(NOT RETURNING THIS DOCUMENT COULD RESULT IN YOUR NAME BEING REMOVED FROM FURTHER KCHA SOLICITATIONS.)**

BID DUE DATE: May 27, 2026

PROJECT NAME: Greenbridge Apt. Buildings A, B & C Walkway Repairs

RETURN FORM TO: antoniw@kcha.org

**\*\*NOTE: Contractors have the option to mail in the No Participation Response Form, but this form must be received by the deadline of 11:00AM. KCHA does not recommend mailing in this form due to possible complications or difficulties that may arise with the mail delivery.**

If using the mail, please return the form to: KING COUNTY HOUSING AUTHORITY  
ATTN: Antoni Walker, Project Manager  
600 Andover Park West,  
Tukwila, WA 98188

1. My Company is NOT BIDDING on this Contract because: (check all response(s) that apply:

- Does not perform the requested type of work
- Has other work which would interfere with the proposed work schedule
- Job is too big
- Job is too small
- Can't meet the bonding and/or insurance requirements
- The documents were not received in time to prepare a bid
- The specifications were not clear. Please describe:

---

---

Other:

---

---

2. I would have Bid on this Contract if:

---

---

**COMPANY NAME:** \_\_\_\_\_

**ADDRESS:** \_\_\_\_\_

**CITY-STATE-ZIP** \_\_\_\_\_

**SIGNATURE:** \_\_\_\_\_

PRINCIPAL OR OFFICER

DATE

## C - SECTION

### CONTRACT DOCUMENTS for Bid Package

- C.1 Construction Contract and General Conditions – Sample Template
- C.2 Performance and Payment Bond with Directions (for projects \$35,000 & over)
- C.3 Certificate as to Corporate Principal (If Performance & Payment Bonds are required)
- C.4 Instructions to Bidders for Insurance Requirements
- C.5 Site Specific Safety Plan – List of Plan Requirements
- C.6 Subcontractor Verification
- C.7 Certification of Payments to Influence Federal Transactions (for all subcontracts \$100,000 & over)
- C.8 Disclosure of Lobbying Activities (for all subcontracts \$100,000 & over)
- C.9 Certification of Compliance with Washington State Wage Payment Statutes
- C.10 Vendor Set Up Form
- C.11 Section 3 Individual Certification Form and FAQ's
- C.12 Section 3 Labor Hours Benchmark Status Report – Sample Template

**If selected, the documents that are numbered 2 through 9 will need to be submitted prior to the “Notice of Award” along with a copy of the completed Statement of Intent to Pay Prevailing Wages that you have filed with the Washington State Department of Labor and Industries.**

**CONSTRUCTION CONTRACT / GENERAL CONDITION SAMPLES**

**PLEASE SEE ATTACHED  
AIA DOCUMENTS**

# AIA® Document A101® – 2017

## Standard Form of Agreement Between Owner and Contractor where the basis of payment is a Stipulated Sum

*As modified by the King County Housing Authority*

AGREEMENT made as of the  day of  in the year **2026**

*(In words, indicate day, month and year.)*

CONTRACT NUMBER: **AW2501531**

BETWEEN the Owner:

*(Name, legal status, address and other information)*

**KING COUNTY HOUSING AUTHORITY**

600 Andover Park West  
Tukwila, Washington 98188

and the Contractor:

*(Name, legal status, address and other information)*

**NAME OF CONTRACTOR**

Street Address  
City, State Zip

for the following Project:

*(Name, location and detailed description)*

**NAME OF SITE: Greenbridge/Salmon Creek**

Street Address: 9915 7<sup>th</sup> Ave.  
City, State Zip: Seattle, WA 98107

**PROJECT NAME: Greenbridge Buildings A, B & C Walkway Repairs**

The Design Professional:

*(Name, legal status, address and other information)*

**NAME OF DESIGN PROFESSIONAL: Pacific Engineering Technologies**

Street Address: 4444 Woodland Park Ave N #100  
City, State Zip: Seattle, WA 98103-7499

The Owner and Contractor agree as follows.

In consideration of the mutual covenants and agreements herein contained, the Contractor agrees to furnish all labor, materials, tools, equipment, and other items necessary to perform and complete all work described in the contract documents. This agreement includes Owner Directed Work as described in the AIA A201-2017 General Conditions as modified by the King County Housing Authority. The Owner Directed Work may or may not be completed under this agreement. If the Owner elects to exclude any or all Owner directed Work Items, an adjustment shall be made to this Agreement as provided in the AIA A201-2017 General Conditions as modified by the King County Housing Authority.

### ADDITIONS AND DELETIONS:

The author of this document may have revised the text of the original AIA standard form. An *Additions and Deletions Report* that notes revisions to the standard form text is available from the author and should be reviewed. A vertical line in the left margin of this document indicates where the author has added to or deleted from the original AIA text.

This document has important legal consequences. Consultation with an attorney is encouraged with respect to its completion or modification.

The parties should complete A101®-2017, Exhibit A, Insurance and Bonds, contemporaneously with this Agreement. AIA Document A201®-2017, General Conditions of the Contract for Construction, is adopted in this document by reference. Do not use with other general conditions unless this document is modified.

**ELECTRONIC COPYING** of any portion of this AIA® Document to another electronic file is prohibited and constitutes a violation of copyright laws as set forth in the footer of this document.

**TABLE OF ARTICLES**

- 1 THE CONTRACT DOCUMENTS
- 2 THE WORK OF THIS CONTRACT
- 3 DATE OF COMMENCEMENT AND SUBSTANTIAL COMPLETION
- 4 CONTRACT SUM
- 5 PAYMENTS
- 6 DISPUTE RESOLUTION
- 7 TERMINATION OR SUSPENSION
- 8 MISCELLANEOUS PROVISIONS
- 9 ENUMERATION OF CONTRACT DOCUMENTS

**ARTICLE 1 THE CONTRACT DOCUMENTS**

The Contract Documents consist of this Agreement, Conditions of the Contract (General, Supplementary, and other Conditions), Drawings, Specifications, Exhibits, Addenda issued prior to execution of this Agreement, other documents listed in this Agreement, and Modifications issued after execution of this Agreement, all of which form the Contract, and are as fully a part of the Contract as if attached to this Agreement or repeated herein. The Contract represents the entire and integrated agreement between the parties hereto and supersedes prior negotiations, representations, or agreements, either written or oral. An enumeration of the Contract Documents, other than a Modification, appears in Article 9.

**ARTICLE 2 THE WORK OF THIS CONTRACT**

The Contractor shall fully execute the Work described in the Contract Documents, except as specifically indicated in the Contract Documents to be the responsibility of others. The Contractor shall comply with the Detailed Summary of the Scope of Work attached as Exhibit A.

**ARTICLE 3 DATE OF COMMENCEMENT AND SUBSTANTIAL COMPLETION**

§ 3.1 The date of commencement of the Work shall be:

*(Check one of the following boxes.)*

- The date of this Agreement.
- A date set forth in a notice to proceed issued by the Owner.
- Established as follows:

*(Insert a date or a means to determine the date of commencement of the Work.)*

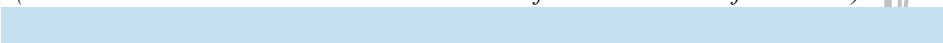

§ 3.2 The Contract Time shall be measured from the date of commencement of the Work, as indicated in the Notice to Proceed.

**§ 3.3 Substantial Completion**

§ 3.3.1 Subject to adjustments of the Contract Time as provided in the Contract Documents, the Contractor shall (i) achieve Substantial Completion of the entire Work no later than the date set forth in the Notice to Proceed, which shall be not less than 14 calendar days after the date of commencement of the work set forth in the Notice to Proceed and (ii) if portions of the Work are to be completed prior to Substantial Completion of the entire Work, then Contractor shall achieve Substantial Completion of such portions of the Work in accordance with the table set forth below.

Portion(s) of Work	Dates
Contract Start Date	Month, Day, Year
Construction Period	Month, Day, Year to Month, Day, Year
Substantial Completion of Work Date	Month, Day, Year
Physical Completion Date	Month, Day, Year (Liquidated Damages Start)
Contract (Final) Completion Date	Month, Day, Year

§ 3.3.2 If the Contractor fails to achieve Substantial Completion as provided in this Section 3.3, or by Change Orders as provided in KCHA General Conditions Sections 7.2, 7.3 and 7.4, liquidated damages, if any, shall be assessed as set forth in Section 4.5.

**ARTICLE 4 CONTRACT SUM**

§ 4.1 The Owner shall pay the Contractor the Contract Sum in current funds for the Contractor’s performance of the Contract. The Contract Sum shall be **Amt in Words (\$Amt)**, subject to additions and deductions as provided in the Contract Documents.

**§ 4.2 Alternates**

§ 4.2.1 Alternates, if any, included in the Contract Sum:

Alternate Number and Description	Price
NA	\$

§ 4.2.2 Subject to the conditions noted below, the following alternates may be accepted by the Owner following execution of this Agreement. Upon acceptance, the Owner shall issue a Modification to this Agreement. *(Insert below each alternate and the conditions that must be met for the Owner to accept the alternate.)*

Item	Condition for Acceptance	Price
		\$

§ 4.3 Allowances, if any, included in the Contract Sum: *(Identify each allowance.)*

Allowance Description	Price
Owner’s Contingency	\$86,000.00

§ 4.4 Unit prices, if any:

*(Identify the item and state the unit price and quantity limitations, if any, to which the unit price will be applicable.)*

Unit prices may be used, as applicable, for unforeseen conditions as identified in the bid documents B1 Unit Pricing (**Exhibit H Contractor’s Bid Documents**). An unforeseen condition requiring large quantities resulting in a substantial change in the Scope of Work will not be considered applicable for unit pricing. Large deviations in the Scope of Work will be evaluated and addressed through a change order process as stipulated in the Contract Documents. The Owner’s Contingency may be applied to Work items charged on a per-unit basis.

Unit Item Description	Price
NA	\$
NA	\$
NA	\$

§ 4.5 Liquidated damages, if any:

*(Insert terms and conditions for liquidated damages, if any.)*

Timely performance and completion of the Work is essential to the Owner. Time is of the essence. Owner will incur serious and substantial damages if Substantial Completion of the Work, or any specified portion thereof, does not occur in the time limits defined in this Agreement. Liquidated Damages will not be assessed as a penalty, but as Liquidated Damages for breach of contract. The amount(s) below are fixed and agreed upon by the Contractor and Owner as a reasonable estimate of Owner’s probable damages due to the extreme difficulty and impracticability of fixing and ascertaining the actual damages the Owner would sustain. These amounts shall be deemed an actual amount of damages to the Owner and may be retained by the Owner and deducted from any payment to the Contractor for obligations in the Agreement. If different and separate completion dates are stated in the Agreement for separate parts or stages of the Work, the amount of Liquidated Damages shall apply and may be assessed on those parts or those stages of the Work which are delayed. The Liquidated Damages specified below are cumulative, not exclusive, and Contractor’s payment of Liquidated Damages shall not excuse Contractor’s failure to perform under this Agreement or be deemed to limit Owner’s Claim for actual damages. The Owner therefore may impose and assess Liquidated Damages in the amount(s) **per calendar day:**

<b>One Thousand Five Hundred Dollars and Zero Cents</b>	<b>\$1500.00</b>

§ 4.6 Other:

*(Insert provisions for bonus or other incentives, if any, that might result in a change to the Contract Sum.)*

NA

**ARTICLE 5 PAYMENTS**

**§ 5.1 Progress Payments**

§ 5.1.1 Based upon Applications for Payment submitted to the Owner by the Contractor, the Owner shall make progress payments on account of the Contract Sum to the Contractor as provided below and elsewhere in the Contract Documents.

§ 5.1.2 The period covered by each Application for Payment shall be one calendar month ending on the last day of the month, or as follows:

NA

§ 5.1.3 Provided that an Application for Payment is received and accepted by the Owner not later than the **25th** day of a month, the Owner shall make payment of the amount certified to the Contractor not later than the **25th** day of the **following** month.

*(Federal, state or local laws may require payment within a certain period of time.)*

§ 5.1.4 Each Application for Payment shall be based on the most recent schedule of values submitted by the Contractor in accordance with the Contract Documents. The schedule of values shall allocate the entire Contract Sum among the various portions of the Work. The schedule of values shall be prepared in such form, and supported by such data to substantiate its accuracy, as Owner may require. This schedule, unless objected to by the Owner, shall be used as a basis for reviewing the Contractor's Applications for Payment.

§ 5.1.5 Applications for Payment shall show the percentage of completion of each portion of the Work as of the end of the period covered by the Application for Payment.

§ 5.1.6 In accordance with the KCHA General Conditions, and subject to other provisions of the Contract Documents, the amount of each progress payment shall be computed as follows:

- .1 The amount of each progress payment shall first include:
  - .a That portion of the Contract Sum properly allocable to completed Work;
  - .b That portion of the Contract Sum properly allocable to materials and equipment delivered and suitably stored at the site for subsequent incorporation in the completed construction, or, if approved in advance by the Owner, suitably stored off the site at a location agreed upon in writing.
- .2 The amount of each progress payment shall then be reduced by:
  - .a The aggregate of any amounts previously paid by the Owner;
  - .b The amount, if any, for Work that remains uncorrected and for which the Owner has previously withheld payment in accordance with the Contract Documents;
  - .c Any amount for which the Contractor does not intend to pay a Subcontractor or material supplier, unless the Work has been performed by others the Contractor intends to pay;
  - .d For Work performed or defects discovered since the last payment application, any amount for which the Owner may withhold payment as provided in the KCHA General Conditions; and
  - .e Retainage withheld pursuant to Section 5.1.7.

§ 5.1.6.3 The General Contractor Certification upon Application for Payment form, per **Exhibit B will accompany each Application for Payment**. By submitting an Application for Payment, the Contractor certifies, agrees and warrants to the Owner as follows:

- .1 The Contractor has made full payment to all laborers, subcontractors and suppliers of material and equipment whose charges were included in any prior Application for Payment, subject only to (a) retainage at the contract rate, and (b) the matters set forth below or on an attachment hereto.
- .2 The Contractor knows of no one making a claim for payment other than those included in the current Application for Payment, who will be paid when the current Application for Payment is paid by the Owner, except as noted in the Application for Payment.
- .3 In consideration of payments made by the Owner, the Contractor waives and releases any and all claims and demands against Owner and the Project for all periods up to and including the period covered by each

Application for Payment, subject only to (a) receipt of payment of the current Application, (b) applicable retainage, and (c) the matters set forth on the Application for Payment.

**§ 5.1.7 Retainage**

**§ 5.1.7.1** For each progress payment made prior to Substantial Completion of the Work, the Owner may withhold the following amount, as retainage, from the payment otherwise due:

*(Insert a percentage or amount to be withheld as retainage from each Application for Payment. The amount of retainage may be limited by governing law.)*

**Five Percent (5%)**

**§ 5.1.7.1.1** The following items are not subject to retainage:

*(Insert any items not subject to the withholding of retainage, such as general conditions, insurance, etc.)*

**NA**

**§ 5.1.7.2** Reduction or limitation of retainage, if any, shall be as follows:

*(If the retainage established in Section 5.1.7.1 is to be modified prior to Substantial Completion of the entire Work, including modifications for Substantial Completion of portions of the Work as provided in Section 3.3.2, insert provisions for such modifications.)*

**NA**

**§ 5.1.7.3** Retainage shall be held at the rate stated in § 5.1.7.1 for the duration of the project. There shall be no reduction or limitation of retainage. There shall also be no early release of retainage by the Owner to the Contractor. The Owner is required by RCW 60.28.051 to obtain all releases in relation to Contractor compliance from the Washington State Department of Revenue, the Washington State Department of Labor and Industries, and the Washington State Department of Employment Security prior to any release of retention by the Owner to the Contractor.

**§ 5.1.8** If final completion of the Work is materially delayed through no fault of the Contractor, the Owner shall pay the Contractor any additional amounts in accordance with Article 9 of the KCHA General Conditions.

**§ 5.1.9** Except with the Owner's prior approval, the Contractor shall not make advance payments to suppliers for materials or equipment which have not been delivered and stored at the site.

**§ 5.2 Final Payment**

**§ 5.2.1** Subject to applicable law and Section 5.1.7 above, final payment, constituting the entire unpaid balance of the Contract Sum, shall be made by the Owner to the Contractor when

- .1 the Contractor has fully performed the Contract except for the Contractor's responsibility to correct Work as provided in Article 12 of the KCHA General Conditions, and to satisfy other requirements, if any, which extend beyond final payment; and
- .2 a final Application for Payment has been approved by the Owner;
- .3 verification of final Affidavits of Wages Paid (L&I) is provided by the Contractor to the Owner;
- .4 final Review and Approval of all Certified Payroll Documents by Owner for all Prevailing Wages.

**§ 5.2.2** Subject to applicable law and Sections 5.1.7 and Section 5.2.1 above, the Owner's final payment to the Contractor shall be made no later than 30 days after the Owner's approval of the Final Application for Payment.

**ARTICLE 6 DISPUTE RESOLUTION**

§ 6.1 Any claim between the Owner and Contractor shall be resolved in accordance with the provisions set forth in Article 15 of the KCHA General Conditions.

**ARTICLE 7 TERMINATION OR SUSPENSION**

§ 7.1 The Contract may be terminated by the Owner or the Contractor as provided in Article 14 of the KCHA General Conditions.

§ 7.2 The Work may be suspended by the Owner as provided in Article 14 of the KCHA General Conditions.

**ARTICLE 8 MISCELLANEOUS PROVISIONS**

§ 8.1 Where reference is made in this Agreement to a provision of the KCHA General Conditions or another Contract Document, the reference refers to that provision as amended or supplemented by other provisions of the Contract Documents.

**§ 8.2 The Owner’s representative:**

(Name, address, email address, and other information)

**Victor Vo, Construction Program Manager**

Choose a PM  
Choose a CC

Antoni Walker  
Chrissie Seilie

Email Address: antoniw@kcha.org  
Email Address: Chrissies@kcha.org

**§ 8.3 The Contractor’s representative:**

(Name, address, email address, and other information)

**Name**

John Doe

**Title**

President

§ 8.4 Neither the Owner’s nor the Contractor’s representative shall be changed without ten days’ prior notice to the other party.

**§ 8.5 Insurance and Bonds**

§ 8.5.1 The Contractor shall purchase and maintain insurance as set forth the General Conditions, Exhibit C, and elsewhere in the Contract Documents.

**Type of Insurance or Bond**

Liability Insurance Requirements  
Builders Risk Insurance  
Performance and Payment Bond

Limits and Coverages  
Completed Value of Project  
Gross Contract Amount

**Limit of Liability or Bond Amount (\$0.00)**

See [Exhibit - C](#)  
See [Exhibit - C](#)  
100%

**§ 8.6 Other Provisions**

**§ 8.6.1 Section 3: Instruction, Requirements and Income Guidelines**

§ 8.6.1.1 The Contractor shall comply with all requirements of the Section 3 Program for Economic Opportunities providing to the greatest extent possible, job training, employment and contract opportunities for low and very low-income residents including persons who are recipients of HUD assistance for housing, with preference for both targeted workers living in the service area or neighborhood of the Development and Youthbuild participants, as defined at 24 CFR Part 75 per [Exhibit D.1-D.4](#) and as designated in the KCHA General Conditions.

§ 8.6.1.1 Section 3 is not required for this project.

**§ 8.6.2 Davis-Bacon / HUD Non-Routine Maintenance Wage Rates and Certified Payrolls**

**§ 8.6.2.1** The Contractor shall comply with all requirements and regulations of the Davis-Bacon Act or HUD’s Labor Standards Non-Routine Maintenance per **Exhibits E.1 and E.2** and the following:

- .1 Payment of Wages to Workers shall be weekly.
- .2 Certified Payroll Reports recording wages paid to each worker will be submitted to the Owner weekly.
- .3 Failure to submit weekly Certified Payroll Reports or errors in Certified Payroll Reports for the Contractor and any and all Subcontractors, and Lower-Tier Subcontractors will be cause for the Owner to suspend or delay Contract Progress Payments.
- .4 The Owner shall withhold progress payments until all issues regarding full compliance with the submission of Certified Payroll Reports are resolved to the complete and full satisfaction of the Owner.
- .5 The Contractor is required and shall perform a complete review of all Certified Payroll Reports including those of the Contractor, and all Subcontractors and any and all Lower-Tier Subcontractors prior to the Submission of the reports by the Contractor to the Owner.
- .6 Lock-In Date: For contracts entered into pursuant to competitive bidding procedures, the bid opening date ‘locks-in’ the wage decision provided that the contract is awarded within sixty (60) days. If the contracts is awarded more than sixty (60) days after the bid opening, the contract award date ‘locks-in’ the wage decision.
- .7 The HUD Non-Routine Wage decision for this project is dated: 02/01/23

**§ 8.6.2.2 Prevailing Wage Exemption**

- .1 When a Contractor claims an exemption from State Prevailing Wage Requirements on HUD projects (i.e., paying either Davis-Bacon or HUD Non-Routine Maintenance Wage Rates), the Contractor and all Subcontractors and all tiers must file an Intent to Pay Prevailing Wage and Affidavit of Wages Paid with the Washington State Department of Labor and Industries for that project.
- .2 The Statement of Intent must also include an Exemption Claim stating that the project is exempt from the payment of State Prevailing Wage Rates based on the Housing Act of 1937 and 24CFR 965.101 and further stating that all workers will be paid in accordance with the requirements of either the Davis-Bacon Act or HUD’s Labor Standard Non-Routine Maintenance, per **Exhibit E.2**.
- .3 Pursuant to RCW 39.12.040, the Owner will not make any payments to a Contractor who has not submitted an Intent Form that has been approved by the Washington State Department of Labor and Industries Industrial Statistician, or release funds retained until the Contractor and all tiers have submitted Affidavit forms that have been certified by the Industrial Statistician.

**§ 8.6.3 Safety Plan**

**§ 8.6.3.1** The Contractor and each Sub-Contractor at each tier shall designate a responsible member of their organization at the site whose duty shall be the health and safety of its employees and all Owner staff or residents that their staff may come into contact with during performance of the Work per Article 10 of the KCHA General Conditions.

**§ 8.6.3.2** The Contractor will supply the Owner with a site-specific safety plan (**Exhibit G**) that includes all items as listed in the KCHA Site-Specific Safety Plan Requirements **Exhibit F**.

**ARTICLE 9 ENUMERATION OF CONTRACT DOCUMENTS**

**§ 9.1** This Agreement is comprised of the following documents:

- .1 King County Housing Authority Construction Contract Based on the AIA Document A101™–2017, Standard Form of Agreement Between Owner and Contractor
- .2 King County Housing Authority Construction General Conditions Based on the King County Housing Authority Construction General Conditions Based on the AIA Document A201™–2017, General Conditions of the Contract for Construction
- .3 Drawings

Drawing No.	Drawing Title	Date of Issuance	Drawing Count
Refer to <b>Exhibit H</b>	Table of Contents – Bid Book (Items listed under TOC 4.D)	Click or tap to enter a date.	

- .4 Specifications

Section	Section Name	Date of Issuance	Page Count
---------	--------------	------------------	------------

Refer to <a href="#">Exhibit I</a>	Table of Contents – Bid Book (Items listed under TOC 4.C)	Click or tap to enter a date.	
------------------------------------	--	-------------------------------	--

**.5 Addenda, if any:**

Addendum No.	Description	Date of Issuance	Page Count
		Click or tap to enter a date.	
		Click or tap to enter a date.	
		Click or tap to enter a date.	

Portions of Addenda relating to bidding or proposal requirements are not part of the Contract Documents unless the bidding or proposal requirements are also enumerated in this Article 9.

**.6 Exhibits**

Where there is conflict between documentation, the Scope of Work shall govern followed by the specifications and lastly the drawings.

EXHIBIT	DESCRIPTION
Exhibit – A	Detailed Scope of Work
Exhibit – B	Application for Payment – GC Certification
Exhibit – C	Insurance Requirements: Limits, Coverage, Builders Risk
Exhibit – D.1	Section 3: Contractor’s Business Certification (NA)
Exhibit – D.2	Section 3: Clause (NA)
Exhibit – D.3	Section 3: Individual Certification and FAQ’s (NA)
Exhibit – D.4	Section 3: Labor Hours Benchmark Status Report (NA)
Exhibit – E.1	Certified Payroll: Requirements for Certified Payroll
Exhibit – E.2	Prevailing Wage Exemption Statement of Intent
Exhibit – E.3	Certified Payroll: Preliminary CPR Overview
Exhibit – F	KCHA Site-Specific Safety Plan Requirements
Exhibit – G	Contractor’s Site-Specific Safety Plan
Exhibit – H	Table of Contents – Drawings
Exhibit – I	Table of Contents – Specifications
Exhibit – J	Contractor’s Bid Documents
Exhibit – K	Construction Change Directive (CCD)
Exhibit – L.1	Change Order Request (COR)
Exhibit – L.2	Change Order Request – General Contractor Breakdown Summary (GC-COR)
Exhibit – L.3	Change Order Request – Sub-contractor Breakdown Summary (SC-COR)
Exhibit – L.4	Change Order Request – Lower-Tier Sub-contractor Breakdown Summary (SC-Lower-COR)
Exhibit – M	Change Order Approval (CO)

**.7 Other documents, if any, listed below:**

(List here any additional documents that are intended to form part of the Contract Documents. KCHA General Conditions provides that the advertisement or invitation to bid, Instructions to Bidders, sample forms, the Contractor’s bid or proposal, portions of Addenda relating to bidding or proposal requirements, and other information furnished by the Owner in anticipation of receiving bids or proposals, are not part of the Contract Documents unless enumerated in this Agreement. Any such documents should be listed here only if intended to be part of the Contract Documents.)

# AIA® Document A201® – 2017

## General Conditions of the Contract for Construction

*As modified by the King County Housing Authority*

**CONTRACT NUMBER:** AW2501531

**THE OWNER:**

*(Name, legal status, and address)*

**KING COUNTY HOUSING AUTHORITY**

600 Andover Park West  
Tukwila, Washington 98188

**THE CONTRACTOR:**

*(Name, legal status, and address)*

**NAME OF CONTRACTOR**

Street Address  
City, State Zip

**for the following PROJECT:**

*(Name and location or address)*

**NAME OF SITE:** Greenbridge/Salmon Creek

Site Address: 9915 7<sup>th</sup> Ave  
City, State Zip: Seattle, WA 98107

**PROJECT NAME:** Greenbridge Buildings A, B & C Walkway Repairs

**The Design Professional:**

*(Name, legal status, and address)*

**NAME OF DESIGN PROFESSIONAL:** Pacific Engineering Technologies

Street Address: 4444 Woodland Park Ave N #100  
City, State Zip: Seattle, WA 98103-7499

**ADDITIONS AND DELETIONS:**  
The author of this document may have revised the text of the original AIA standard form. An *Additions and Deletions Report* that notes revisions to the standard form text is available from the author and should be reviewed. A vertical line in the left margin of this document indicates where the author has added to or deleted from the original AIA text.

This document has important legal consequences. Consultation with an attorney is encouraged with respect to its completion or modification.

For guidance in modifying this document to include supplementary conditions, see AIA Document A503™–2017, Guide for Supplementary Conditions.

**ELECTRONIC COPYING** of any portion of this AIA® Document to another electronic file is prohibited and constitutes a violation of copyright laws as set forth in the footer of this document.

## TABLE OF ARTICLES

### 1. GENERAL PROVISIONS

- 1.1 Basic Definitions
- 1.2 Correlation and Intent of the Contract Documents
- 1.3 Capitalization
- 1.4 Interpretation
- 1.5 Ownership and Use of Drawings, Specifications, and Other Instruments of Service
- 1.6 Notice
- 1.7 Digital Data Use and Transmission

### 2. OWNER

- 2.1 General
- 2.2 Information and Services Required of the Owner
- 2.3 Owner's Right to Stop the Work
- 2.4 Owner's Right to Carry Out the Work

### 3. CONTRACTOR

- 3.1 General
- 3.2 Review of Contract Documents and Field Condition by Contractor
- 3.3 Supervision and Construction Procedures
- 3.4 Labor and Materials
- 3.5 Warranty
- 3.6 Taxes
- 3.7 Permits, Fees, Notices and Compliance with Laws
- 3.8 Allowances
- 3.9 Superintendent
- 3.10 Contractor's Master Project Schedule
- 3.11 Documents and Samples at the Site
- 3.12 Shop Drawings
- 3.13 Use of Site
- 3.14 Cutting and Patching
- 3.15 Cleaning Up
- 3.16 Access to Work
- 3.17 Royalties, Patents and Copyrights
- 3.18 Indemnification

### 4. DESIGNER; OWNER ADMINISTRATION OF CONTRACT

- 4.1 General
- 4.2 Administration of the Contract by Owner

### 5. SUBCONTRACTORS

- 5.1 Definitions
- 5.2 Award of Subcontracts and Other Contracts for Portions of the Work
- 5.3 Sub-contractual Relations
- 5.4 Contingent Assignment of Subcontracts

### 6. CONSTRUCTION BY OWNER OR BY SEPARATE CONTRACTORS

- 6.1 Owner's Right to Perform Construction and to Award Separate Contracts
- 6.2 Mutual Responsibility
- 6.3 Owner's Right to Clean Up

### 7. CHANGES IN WORK

- 7.1 General
- 7.2 Construction Change Directives
- 7.3 Change Order Requests

- 7.4 Change Orders
- 7.5 Minor Changes in the Work
  
- 8. TIME**
  - 8.1 Definitions
  - 8.2 Progress and Completion
  - 8.3 Delays and Extensions of Time
  
- 9. PAYMENTS AND COMPLETION**
  - 9.1 Contract Sum
  - 9.2 Schedule of Values
  - 9.3 Applications for Payment
  - 9.4 Decisions to Withhold Payment
  - 9.5 Progress Payments
  - 9.6 Failure of Payment
  - 9.7 Substantial Completion
  - 9.8 Partial Occupancy or Use
  - 9.9 Final Completion and Final Payment
  
- 10. PROTECTION OF PERSONS AND PROPERTY**
  - 10.1 Safety Precautions and Programs
  - 10.2 Safety of Persons and Property
  - 10.3 Injury or Damage to Person or Property
  - 10.4 Hazardous Materials and Substances
  - 10.5 Emergencies
  
- 11. INSURANCE AND BONDS**
  - 11.1 Contractor's Insurance and Bonds
  - 11.2 Owner's Insurance
  - 11.3 Waivers of Subrogation
  - 11.4 Loss of use, Business Interruption, and Delay in Completion Insurance
  - 11.5 Adjustment and Settlement of Insured Loss
  - 11.6 Performance Bond and Payment Bond
  
- 12. UNCOVERING AND CORRECTION OF WORK**
  - 12.1 Uncovering of Work
  - 12.2 Correction of Work
  - 12.3 Acceptance of Nonconforming Work
  
- 13. MISCELLANEOUS PROVISIONS**
  - 13.1 Governing Law
  - 13.2 Successors and Assigns
  - 13.3 Rights and Remedies
  - 13.4 Tests and Inspections
  
- 14. TERMINATION OR SUSPENSION OF THE CONTRACT**
  - 14.1 Termination by the Contractor
  - 14.2 Termination by the Owner for Cause
  - 14.3 Suspension by the Owner for Convenience
  - 14.4 Termination by the Owner for Convenience
  
- 15. CLAIMS AND DISPUTES**
  - 15.1 Claims
  - 15.2 Mediation
  - 15.3 Arbitration
  - 15.4 Consolidation or Joinder

**16. AUDITS AND INSPECTIONS**

16.1 Audits and Inspections

**17. FEDERAL PROVISIONS**

- 17.1 Section 3 Instructions, Requirements and Income Guidelines
- 17.2 Prohibition Against the Use of Lead Based Paint
- 17.3 Federal Health, Safety, and Accident Prevention
- 17.4 Clean Air and Water
- 17.5 Energy Efficiency
- 17.6 Wage Decision HUD Non-Routine Maintenance
- 17.7 Interest of Members of Congress
- 17.8 Interest of Members, Officers, Commissioners and Employees, or Former Members, Officers and Employees
- 17.9 Organization Conflicts of Interest
- 17.10 Lobbying



## **ARTICLE 1 GENERAL PROVISIONS**

### **§ 1.1 Basic Definitions**

#### **§ 1.1.1 The Contract Documents**

The Contract Documents are enumerated in the AIA Document A101-2017 Standard Form of Agreement Between the Owner and Contractor as modified by the King County Housing Authority (hereinafter the Agreement) and consist of the Agreement, Conditions of the Contract (General, Supplementary and other Conditions), Scope of Work, Drawings, Bid Documents, Specifications, Addenda issued prior to execution of the Contract, other documents listed in the Agreement, and Modifications issued after execution of the Contract. A Modification is (1) a written amendment to the Contract signed by both parties, (2) a Change Order, (3) a Construction Change Directive, or (4) a written order for a minor change in the Work issued by the Owner. Unless specifically enumerated in the Agreement, the Contract Documents do not include the advertisement or invitation to bid, Instructions to Bidders, sample forms, other information furnished by the Owner in anticipation of receiving bids or proposals, the Contractor's bid or proposal, or portions of Addenda relating to bidding or proposal requirements.

#### **§ 1.1.2 The Contract**

The Contract Documents form the Contract for Construction. The Contract represents the entire and integrated agreement between the parties hereto and supersedes prior negotiations, representations, or agreements, either written or oral. The Contract may be amended or modified only by a Modification. The Contract Documents shall not be construed to create a contractual relationship of any kind (1) between the Contractor and the Designer or the Designer's consultants, (2) between the Owner and a Subcontractor or a Lower-Tier Subcontractor, (3) between the Owner and the Designer or the Designer's consultants, or (4) between any persons or entities other than the Owner and the Contractor. The Designer shall, however, be entitled to performance and enforcement of obligations under the Contract intended to facilitate performance of the Designer's duties.

#### **§ 1.1.3 The Work**

The term "Work" means the construction and services required by the Contract Documents, whether completed or partially completed, and includes all other labor, materials, equipment, and services provided or to be provided by the Contractor to fulfill the Contractor's obligations. The Work may constitute the whole or a part of the Project.

#### **§ 1.1.4 The Project**

The Project is the total construction of which the Work performed under the Contract Documents may be the whole or a part and which may include construction by the Owner and by Separate Contractors.

#### **§ 1.1.5 The Drawings**

The Drawings are the graphic and pictorial portions of the Contract Documents showing the design, location and dimensions of the Work, generally including plans, elevations, sections, details, schedules, and diagrams.

#### **§ 1.1.6 The Specifications**

The Specifications are that portion of the Contract Documents consisting of the written requirements for materials, equipment, systems, standards and workmanship for the Work, and performance of related services.

#### **§ 1.1.7 Instruments of Service**

Instruments of Service are representations, in any medium of expression now known or later developed, of the tangible and intangible creative work performed by the Designer and the Designer's consultants under their respective professional services agreements. Instruments of Service may include, without limitation, studies, surveys, models, sketches, drawings, specifications, and other similar materials.

### **§ 1.2 Correlation and Intent of the Contract Documents**

**§ 1.2.1** The intent of the Contract Documents is to include all items necessary for the proper execution and completion of the Work by the Contractor. The Contract Documents are complementary, and what is required by one shall be as binding as if required by all; performance by the Contractor shall be required only to the extent consistent with the Contract Documents and reasonably inferable from them as being necessary to produce the indicated results.

**§ 1.2.1.1** The invalidity of any provision of the Contract Documents shall not invalidate the Contract or its remaining provisions. If it is determined that any provision of the Contract Documents violates any law, or is otherwise invalid or unenforceable, then that provision shall be revised to the extent necessary to make that provision legal and enforceable. In such

case the Contract Documents shall be construed, to the fullest extent permitted by law, to give effect to the parties' intentions and purposes in executing the Contract.

**§ 1.2.2** Organization of the Specifications into divisions, sections and articles, and arrangement of Drawings shall not control the Contractor in dividing the Work among Subcontractors or in establishing the extent of Work to be performed by any trade.

**§ 1.2.3** Unless otherwise stated in the Contract Documents, words that have well-known technical or construction industry meanings are used in the Contract Documents in accordance with such recognized meanings.

### **§ 1.3 Capitalization**

Terms capitalized in these General Conditions include those that are (1) specifically defined, (2) the titles of numbered articles, or (3) the titles of other documents published by the American Institute of Architects.

### **§ 1.4 Interpretation**

In the interest of brevity the Contract Documents frequently omit modifying words such as "all" and "any" and articles such as "the" and "an," but the fact that a modifier or an article is absent from one statement and appears in another is not intended to affect the interpretation of either statement.

### **§ 1.5 Ownership and Use of Drawings, Specifications, and Other Instruments of Service**

**§ 1.5.1** The Designer and the Designer's consultants shall be deemed the authors and owners of their respective Instruments of Service, including the Drawings and Specifications, and retain all common law, statutory, and other reserved rights in their Instruments of Service, including copyrights. The Contractor, Subcontractors, Lower-Tier Subcontractors, and suppliers shall not own or claim a copyright in the Instruments of Service. Submittal or distribution to meet official regulatory requirements or for other purposes in connection with the Project is not to be construed as publication in derogation of the Designer's or Designer's consultants' reserved rights.

**§ 1.5.2** The Contractor, Subcontractors, Lower-Tier Subcontractors, and suppliers are authorized to use and reproduce the Instruments of Service provided to them solely and exclusively for execution of the Work. All copies made under this authorization shall bear the copyright notice, if any, shown on the Instruments of Service. The Contractor, Subcontractors, Lower-Tier Subcontractors, and suppliers may not use the Instruments of Service on other projects or for additions to the Project outside the scope of the Work without the specific written consent of the Owner, Designer, and the Designer's consultants.

### **§ 1.6 Notice**

**§ 1.6.1** Except as otherwise provided in Section 1.6.2, where the Contract Documents require one party to notify or give notice to the other party, such notice shall be provided in writing to the designated representative of the party to whom the notice is addressed and shall be deemed to have been duly served if delivered in person, by mail, by courier, or by email to [antoniv@kcha.org](mailto:antoniv@kcha.org).

**§ 1.6.2** Notice of Claims as provided in Section 15.1.3 shall be provided in writing and shall be deemed to have been duly served only if delivered to the designated representative of the party to whom the notice is addressed by certified or registered mail, or by courier providing proof of delivery.

### **§ 1.7 Digital Data Use and Transmission**

If the parties intend to transmit Instruments of Service or any other information or documentation in digital form, they shall endeavor to establish necessary protocols governing such transmissions, unless otherwise already provided in the Agreement or the Contract Documents.

## **ARTICLE 2 OWNER**

### **§ 2.1 General**

**§ 2.1.1** The Owner is the person or entity identified as such in the Agreement and is referred to throughout the Contract Documents as if singular in number.

### **§ 2.2 Information and Services Required of the Owner**

**§ 2.2.1** Except for permits and fees that are the responsibility of the Contractor under the Contract Documents, including those

AIA Document A201 – 2017. Copyright © 1911, 1915, 1918, 1925, 1937, 1951, 1958, 1961, 1963, 1966, 1970, 1976, 1987, 1997, 2007 and 2017. All rights reserved. "The American Institute of Architects," "American Institute of Architects," "AIA," the AIA Logo, and "AIA Contract Documents" are trademarks of The American Institute of Architects. This draft was produced at 11:21:27 PST on 02/18/2025 under Subscription No.20240033487 which expires on , is not for resale, is licensed for one-time use only, and may only be used in accordance with the AIA Contract Documents® Terms of Service. To report copyright violations, e-mail [docinfo@aiacontracts.com](mailto:docinfo@aiacontracts.com).

**User Notes:**

(640e2aedf442e4498d0967fa)

required under Section 3.7.1, the Owner shall secure and pay for necessary approvals, easements, assessments and charges required for construction, use or occupancy of permanent structures or for permanent changes in existing facilities.

**§ 2.2.2** The Owner may retain an architect lawfully licensed to practice architecture, or an entity lawfully practicing architecture, in the jurisdiction where the Project is located. The Owner may also retain an engineer lawfully licensed to practice engineering, or an entity lawfully practicing engineering, in the jurisdiction where the Project is located. In either event, the person or entity is identified as the Designer in the Agreement and is referred to throughout the Contract Documents as if singular in number.

**§ 2.2.3** If necessary or convenient for completion of the Work, then upon written request by the Contractor, the Owner shall furnish survey(s) describing physical characteristics, legal limitations and utility locations for the site of the Project, and a legal description of the site. The Contractor shall be entitled to rely on the accuracy of information furnished by the Owner but shall exercise proper precautions relating to the safe performance of the Work.

**§ 2.2.4** The Owner shall furnish information or services required of the Owner by the Contract Documents with reasonable promptness. The Owner shall also furnish any other information or services under the Owner's control and relevant to the Contractor's performance of the Work with reasonable promptness after receiving the Contractor's written request for such information or services.

**§ 2.2.5** Unless otherwise provided in the Contract Documents, the Owner shall furnish to the Contractor one copy of the Contract Documents for purposes of making reproductions pursuant to Section 1.5.2.

### **§ 2.3 Owner's Right to Stop the Work**

If the Contractor fails to correct Work that is not in accordance with the requirements of the Contract Documents as required by Section 12.2 or repeatedly fails to carry out Work in accordance with the Contract Documents, the Owner may issue a written order to the Contractor to stop the Work, or any portion thereof, until the cause for such order has been eliminated; however, the right of the Owner to stop the Work shall not give rise to a duty on the part of the Owner to exercise this right for the benefit of the Contractor or any other person or entity, except to the extent required by Section 6.1.3.

### **§ 2.4 Owner's Right to Carry Out the Work**

If the Contractor defaults or neglects to carry out the Work in accordance with the Contract Documents and fails within a fourteen-calendar day period after receipt of notice from the Owner to commence and continue correction of such default or neglect with diligence and promptness, the Owner may, without prejudice to other remedies the Owner may have, correct such default or neglect. In such case an appropriate Change Order shall be issued deducting from payments then or thereafter due the Contractor for the reasonable cost of correcting such deficiencies, including Owner's expenses made necessary by such default, neglect, or failure. If current and future payments are not sufficient to cover such amounts, the Contractor shall pay the difference to the Owner. If the Contractor disagrees with the actions of the Owner, or the amounts claimed as costs to the Owner, the Contractor may file a Claim pursuant to Article 15.

## **ARTICLE 3 CONTRACTOR**

### **§ 3.1 General**

**§ 3.1.1** The Contractor is the person or entity identified as such in the Agreement and is referred to throughout the Contract Documents as if singular in number. The Contractor shall be lawfully licensed, if required in the jurisdiction where the Project is located. The Contractor shall designate in writing a representative who shall have express authority to bind the Contractor with respect to all matters under this Contract. The term "Contractor" means the Contractor or the Contractor's authorized representative.

**§ 3.1.2** The Contractor shall perform the Work in accordance with the Contract Documents.

**§ 3.1.3** The Contractor shall not be relieved of its obligations to perform the Work in accordance with the Contract Documents by activities or duties of the Designer, by the activities or duties of the Owner in the Owner's administration of the Contract, or by tests, inspections or approvals required or performed by persons or entities other than the Contractor.

**§ 3.1.4 Pre-Construction Meetings.** The Owner will conduct a mandatory pre-construction meeting with the Contractor. The meeting will include but is not limited to a review of the scope of work, project schedules, general requirements for construction

work, jobsite security, staging and storage areas, material recycling and salvage, jobsite cleanup, and tests, samples and construction observation. The meeting will also include a review of the submittal process for applications for payment, the change order process, the process for progress payments, the final application for payment, and release of retention. A review of the Certified Payroll process will also be conducted. A separate Certified Payroll training session will be conducted by the Owner with the Contractor and with each subcontractor.

- .1 A separate meeting will be also be conducted by Owner and Contractor to review the Section 3 plan, Master Project Schedule and Bid Documents submitted by the Contractor and to review the Section 3 reporting procedures.
- .2 The Contractor shall contact the local jurisdiction to conduct a pre-construction conference with building officials and other local agencies as applicable for the project.

**§ 3.1.5 Progress Meetings.** The Contractor shall schedule and conduct meetings with the Owner and as determined by the Owner with the Designer also present, to discuss such matters as procedures, progress, coordination, and schedules. Such meetings shall be weekly unless otherwise directed by Owner. The Contractor shall prepare and promptly distribute minutes of each progress meeting to each attendee, including Owner. The Contractor shall also provide a short-term look ahead schedule for presentation and review at each progress meeting. The short-term schedule shall be in sufficient detail to allow the Contractor and Owner to make any necessary schedule modifications to maintain the progress of the Work and for adherence to the time frames stipulated in the Agreement. The following shall also be included in the progress meeting agenda:

- .1 Coordination of architectural, structural, mechanical, electrical, civil work or any other item associated with the Work.
- .2 Measures to mitigate adverse effects of construction on the residents of the development during construction.
- .3 Resolving issues with governing agencies.
- .4 Status of submittals, RFIs, CORs and CCDs.
- .5 Site safety and associated issues.
- .6 Segregated and comingled material recycling reports.
- .7 Section 3 compliance and status.
- .8 Such other items as Owner or Contractor may reasonably request.

**§ 3.1.6** The Contractor shall provide the required tenant notices as directed by the Owner.

### **§ 3.2 Review of Contract Documents and Field Conditions by Contractor**

**§ 3.2.1** Execution of the Contract by the Contractor is a representation that the Contractor has visited the site, become generally familiar with local conditions under which the Work is to be performed, and correlated personal observations with requirements of the Contract Documents.

**§ 3.2.2** Because the Contract Documents are complementary, the Contractor shall, before starting each portion of the Work, carefully study and compare the various Contract Documents relative to that portion of the Work, as well as the information furnished by the Owner pursuant to Section 2.2.4, shall take field measurements of any existing conditions related to that portion of the Work, and shall observe any conditions at the site affecting it. These obligations are for the purpose of facilitating coordination and construction by the Contractor and are not for the purpose of discovering errors, omissions, or inconsistencies in the Contract Documents; however, the Contractor shall promptly report to the Owner any errors, inconsistencies or omissions discovered by or made known to the Contractor as a request for information in such form as the Owner may require. It is recognized that the Contractor's review is made in the Contractor's capacity as a contractor and not as a licensed design professional, unless otherwise specifically provided in the Contract Documents.

- .1 If there is a discrepancy between Scope of Work, Specifications and/or Drawings, the Scope of Work shall take precedence followed by the Specifications and lastly the Drawings.

**§ 3.2.3** The Contractor is not required to ascertain that the Contract Documents are in accordance with applicable laws, statutes, ordinances, codes, rules and regulations, or lawful orders of public authorities, but the Contractor shall promptly report to the Owner any nonconformity discovered by or made known to the Contractor as a request for information in such form as the Owner may require.

**§ 3.2.4** If the Contractor believes that additional cost or time is involved because of clarifications or instructions the Owner issues in response to the Contractor's notices or requests for information pursuant to Sections 2.2.3 or 2.2.4, the Contractor shall submit Claims as provided in Article 15. If the Contractor fails to perform the obligations of Sections 2.2.3 or 2.2.4, the Contractor shall pay such costs and damages to the Owner, subject to Section 15.1.7, as would have been avoided if the Contractor had performed such obligations. If the Contractor performs those obligations, the Contractor shall not be liable to the Owner for damages resulting from errors, inconsistencies or omissions in the Contract Documents, for differences between

field measurements or conditions and the Contract Documents, or for nonconformities of the Contract Documents to applicable laws, statutes, ordinances, codes, rules and regulations, and lawful orders of public authorities.

### **§ 3.3 Supervision and Construction Procedures**

**§ 3.3.1** The Contractor shall supervise and direct the Work, using the Contractor's best skill and attention. The Contractor shall be solely responsible for, and have control over, construction means, methods, techniques, sequences, and procedures, and for coordinating all portions of the Work under the Contract. If the Contract Documents give specific instructions concerning construction means, methods, techniques, sequences, or procedures, the Contractor shall evaluate the jobsite safety thereof and shall be solely responsible for the jobsite safety of such means, methods, techniques, sequences, or procedures. If the Contractor determines that such means, methods, techniques, sequences or procedures may not be safe, the Contractor shall give timely notice to the Owner, and shall propose alternative means, methods, techniques, sequences, or procedures. The Owner shall evaluate the proposed alternative solely for conformance with the design intent for the completed construction. The Contractor shall not proceed with that portion of the Work without further written instructions from the Owner. If the Contractor is then instructed to proceed with the required means, methods, techniques, sequences or procedures without acceptance of changes proposed by the Contractor, the Owner shall be solely responsible for any loss or damage arising solely from those Owner-required means, methods, techniques, sequences or procedures.

**§ 3.3.2** The Contractor shall be responsible to the Owner for acts and omissions of the Contractor's employees, Subcontractors and their agents and employees, and other persons or entities performing portions of the Work for, or on behalf of, the Contractor or any of its Subcontractors.

**§ 3.3.3** The Contractor shall be responsible for inspection of portions of Work already performed to determine that such portions are in proper condition to receive subsequent Work.

### **§ 3.4 Labor and Materials**

**§ 3.4.1** Unless otherwise provided in the Contract Documents, the Contractor shall provide and pay for labor, materials, equipment, tools, construction equipment and machinery, water, heat, utilities, transportation, and other facilities and services necessary for proper execution and completion of the Work, whether temporary or permanent and whether or not incorporated or to be incorporated in the Work.

**§ 3.4.2** The Contractor may make substitutions only with the consent of the Owner evidenced by a Change Order or Construction Change Directive.

**§ 3.4.3** The Contractor shall enforce strict discipline and good order among the Contractor's employees and other persons carrying out the Work. The Contractor shall not permit employment of unfit persons or persons not properly skilled in tasks assigned to them.

### **§ 3.5 Warranty**

**§ 3.5.1** The Contractor warrants to the Owner that materials and equipment furnished under the Contract will be of good quality, new and in conformance with the Contract Documents unless the Contract Documents require or permit otherwise. The Contractor further warrants that the Work will conform to the requirements of the Contract Documents and will be free from defects, except for those inherent in the quality of the Work the Contract Documents require or permit. Work, materials, or equipment not conforming to these requirements may be considered defective. The Contractor's warranty excludes remedy for damage or defect caused by abuse, alterations to the Work not executed by the Contractor, improper or insufficient maintenance, improper operation, or normal wear and tear and normal usage. If required by the Owner, the Contractor shall furnish satisfactory evidence as to the kind and quality of materials and equipment.

**§ 3.5.2** All material, equipment, or other special warranties required by the Contract Documents shall be issued in the name of the Owner, or shall be transferable to the Owner, and shall commence in accordance with Section 9.7.4.

### **§ 3.6 Taxes**

The Contractor shall pay sales, consumer, use and similar taxes for the Work provided by the Contractor that are legally enacted when bids are received or negotiations concluded, whether or not yet effective or merely scheduled to go into effect.

### **§ 3.7 Permits, Fees, Notices and Compliance with Laws**

**§ 3.7.1** Unless otherwise provided in the Contract Documents, the Owner shall secure and pay for the building permit. All other related permits such as demolition, grading, plumbing, electrical, etc. (as applicable to the Work) all fees, licenses, and scheduling inspections by government agencies necessary for the proper execution and completion of the Work that are customarily secured after execution of the Contract and legally required at the time bids are received or negotiations concluded are the responsibility of the Contractor.

**§ 3.7.2** The Contractor shall comply with and give notices required by applicable laws, statutes, ordinances, codes, rules and regulations, and lawful orders of public authorities applicable to performance of the Work.

**§ 3.7.3** If the Contractor performs Work knowing it to be contrary to applicable laws, statutes, ordinances, codes, rules and regulations, or lawful orders of public authorities, the Contractor shall assume appropriate responsibility for such Work and shall bear the costs attributable to correction.

### **§ 3.7.4 Concealed or Unknown Conditions**

If the Contractor encounters conditions at the site that are (1) subsurface or otherwise concealed physical conditions that differ materially from those indicated in the Contract Documents or (2) unknown physical conditions of an unusual nature that differ materially from those ordinarily found to exist and generally recognized as inherent in construction activities of the character provided for in the Contract Documents, the Contractor shall promptly provide notice to the Owner before conditions are disturbed and in no event later than fourteen calendar days after first observance of the conditions. The Owner will promptly investigate such conditions and, if the Owner determines that they differ materially and cause an increase or decrease in the Contractor's cost of, or time required for, performance of any part of the Work, will recommend that an equitable adjustment be made in the Contract Sum or Contract Time, or both. If the Owner determines that the conditions at the site are not materially different from those indicated in the Contract Documents and that no change in the terms of the Contract is justified, the Owner shall promptly notify the Contractor in writing, stating the reasons. If the Contractor disputes the Owner's determination, the Contractor may submit a Claim as provided in Article 15.

**§ 3.7.5** If, in the course of the Work, the Contractor encounters human remains or recognizes the existence of burial markers, archaeological sites or wetlands not indicated in the Contract Documents, the Contractor shall immediately suspend any operations that would affect them and shall notify the Owner. Upon receipt of such notice, the Owner shall promptly take any action necessary to obtain governmental authorization required to resume the operations. The Contractor shall continue to suspend such operations until otherwise instructed by the Owner but shall continue with all other operations that do not affect those remains or features. Requests for adjustments in the Contract Sum and Contract Time arising from the existence of such remains or features may be made as provided in Article 15.

### **§ 3.8 Allowances**

**§ 3.8.1** The Contractor shall include in the Contract Sum all allowances stated in the Contract Documents. Items covered by allowances shall be supplied for such amounts and by such persons or entities as the Owner may direct.

**§ 3.8.2** Unless otherwise provided in the Contract Documents,

- .1 allowances shall cover the cost to the Contractor of materials and equipment delivered at the site and all required taxes, less applicable trade discounts;
- .2 Contractor's costs for unloading and handling at the site, labor, installation costs, overhead, profit, and other expenses contemplated for stated allowance amounts shall be included in the Contract Sum but not in the allowances; and
- .3 whenever costs are more than or less than allowances, the Contract Sum shall be adjusted accordingly by Change Order. The amount of the Change Order shall reflect (1) the difference between actual costs and the allowances under Section 3.8.2.1 and (2) changes in Contractor's costs under Section 3.8.2.2.

### **§ 3.9 Superintendent**

**§ 3.9.1** The Contractor shall employ a competent superintendent and necessary assistants who shall be in attendance at the Project site during performance of the Work. The superintendent shall represent the Contractor, and communications given to the superintendent shall be as binding as if given to the Contractor.

**§ 3.9.2** The Contractor, as soon as practicable after award of the Contract, shall confirm for the Owner the name and qualifications of the superintendent as identified in the Bid Documents. Within 14 days of receipt of the information, the

Owner may notify the Contractor, stating whether the Owner (1) has reasonable objection to the proposed superintendent or (2) requires additional time for review. Failure of the Owner to provide notice within the 14-day period shall constitute notice of no reasonable objection.

**§ 3.9.3** The Contractor shall not employ a proposed superintendent to whom the Owner has made reasonable and timely objection. The Contractor shall not change the superintendent without the Owner's consent, which shall not unreasonably be withheld or delayed.

**§ 3.9.4** The Contractor's Superintendent(s) shall be physically present at the jobsite from daily commencement of work to daily completion of work. The site shall be managed daily without interruption. Daily commencement and daily completion are defined as the actual hours of operation for the project.

### **§ 3.10 Contractor's Master Project Schedule**

**§ 3.10.1** In consultation with the Owner Contractor shall revise the Master Project Schedule at appropriate intervals as required by the conditions of the Work and Project, shall be related to the entire Project to the extent required by the Contract Documents and shall provide for expeditious and practicable execution of the Work.

**§ 3.10.2** The Contractor, promptly after being awarded the Contract shall submit a submittal schedule for the Owner's approval. The Owner's approval shall not be unreasonably delayed or withheld. The submittal schedule shall (1) be coordinated with the Contractor's Master Project Schedule, and (2) the Contractor shall allow Owner at least 14 calendar days to review and approve submittals. If the Contractor fails to submit a submittal schedule, or fails to provide submittals in accordance with the approved submittal schedule, the Contractor shall not be entitled to any increase in Contract Sum or extension of Contract Time based on the time required for review of submittals.

**§ 3.10.3** The Contractor shall perform the Work in general accordance with the most recent schedules submitted to the Owner.

### **§ 3.11 Documents and Samples at the Site**

The Contractor shall make available, at the Project site, the Contract Documents, including Change Orders, Construction Change Directives, and other Modifications, in good order and marked currently to indicate field changes and selections made during construction, and the approved Shop Drawings, Product Data, Samples, and similar required submittals. These shall be in electronic form and paper copy, available to the Owner, and delivered to the Owner upon completion of the Work as a record of the Work as constructed.

### **§ 3.12 Shop Drawings, Product Data and Samples**

**§ 3.12.1** Shop Drawings are drawings, diagrams, schedules, and other data specially prepared for the Work by the Contractor or a Subcontractor, Lower-Tier Subcontractor, manufacturer, supplier, or distributor to illustrate some portion of the Work.

**§ 3.12.2** Product Data are illustrations, standard schedules, performance charts, instructions, brochures, diagrams, and other information furnished by the Contractor to illustrate materials or equipment for some portion of the Work.

**§ 3.12.3** Samples are physical examples that illustrate materials, equipment, or workmanship, and establish standards by which the Work will be judged.

**§ 3.12.4** Shop Drawings, Product Data, Samples, and similar submittals are not Contract Documents. Their purpose is to demonstrate how the Contractor proposes to conform to the information given and the design concept expressed in the Contract Documents for those portions of the Work for which the Contract Documents require submittals. Review by the Designer and/or Owner is subject to the limitations of Section 4.2.7.

**§ 3.12.5** The Contractor shall review for compliance with the Contract Documents, approve, and submit to the Owner, Shop Drawings, Product Data, Samples, and similar submittals required by the Contract Documents, in accordance with the submittal schedule approved by the Owner or, in the absence of an approved submittal schedule, with reasonable promptness and in such sequence as to cause no delay in the Work or in the activities of the Owner or of Separate Contractors.

**§ 3.12.6** By submitting Shop Drawings, Product Data, Samples, and similar submittals, the Contractor represents to the Owner that the Contractor has (1) reviewed and approved them, (2) determined and verified materials, field measurements and field

construction criteria related thereto, or will do so, and (3) checked and coordinated the information contained within such submittals with the requirements of the Work and of the Contract Documents.

**§ 3.12.7** The Contractor shall perform no portion of the Work for which the Contract Documents require submittal and review of Shop Drawings, Product Data, Samples, or similar submittals, until the respective submittal has been approved by the Owner.

**§ 3.12.8** The Work shall be in accordance with approved submittals except that the Contractor shall not be relieved of responsibility for deviations from the requirements of the Contract Documents by the Owner's approval of Shop Drawings, Product Data, Samples, or similar submittals, unless the Contractor has specifically notified the Owner of such deviation at the time of submittal and (1) the Owner has given written approval to the specific deviation as a minor change in the Work, or (2) a Change Order or Construction Change Directive has been issued authorizing the deviation. The Contractor shall not be relieved of responsibility for errors or omissions in Shop Drawings, Product Data, Samples, or similar submittals, by the Owner's approval thereof.

**§ 3.12.9** The Contractor shall direct specific attention, in writing or on resubmitted Shop Drawings, Product Data, Samples, or similar submittals, to revisions other than those requested by the Owner on previous submittals. In the absence of such notice, the Owner's approval of a resubmission shall not apply to such revisions.

**§ 3.12.10** The Contractor shall not be required to provide professional services that constitute the practice of architecture or engineering unless such services are specifically required by the Contract Documents for a portion of the Work or unless the Contractor needs to provide such services in order to carry out the Contractor's responsibilities for construction means, methods, techniques, sequences, and procedures. The Contractor shall not be required to provide professional services in violation of applicable law.

**§ 3.12.10.1** If professional design services or certifications by a design professional related to systems, materials, or equipment are specifically required of the Contractor by the Contract Documents, the Owner will specify all performance and design criteria that such services must satisfy. The Contractor shall be entitled to rely upon the adequacy and accuracy of the performance and design criteria provided in the Contract Documents. The Contractor shall cause such services or certifications to be provided by an appropriately licensed design professional, whose signature and seal shall appear on all drawings, calculations, specifications, certifications, Shop Drawings, and other submittals prepared by such professional. Shop Drawings, and other submittals related to the Work, designed or certified by such professional, if prepared by others, shall bear such professional's written approval when submitted to the Owner. The Owner shall be entitled to rely upon the adequacy and accuracy of the services, certifications, and approvals performed or provided by such design professionals, provided the Owner has specified to the Contractor the performance and design criteria that such services must satisfy. Pursuant to this Section 3.12.10, the Owner will review and approve or take other appropriate action on submittals only for the limited purpose of checking for conformance with information given and the design concept expressed in the Contract Documents. Unless otherwise specified in the Contract Documents, Contractor shall not be responsible for the adequacy of the performance and design criteria specified in the Contract Documents.

**§ 3.12.10.2** If the Contract Documents require the Contractor's design professional to certify that the Work has been performed in accordance with the design criteria, the Contractor shall furnish such certifications to the Owner at the time and in the form specified by the Owner.

### **§ 3.13 Use of Site**

The Contractor shall confine operations at the site to areas permitted by applicable laws, statutes, ordinances, codes, rules and regulations, lawful orders of public authorities, and the Contract Documents and shall not unreasonably encumber the site with materials or equipment.

### **§ 3.14 Cutting and Patching**

**§ 3.14.1** The Contractor shall be responsible for cutting, fitting, or patching required to complete the Work or to make its parts fit together properly. All areas requiring cutting, fitting, or patching shall be restored to the condition existing prior to the cutting, fitting, or patching, unless otherwise required by the Contract Documents.

**§ 3.14.2** The Contractor shall not damage or endanger a portion of the Work or fully or partially completed construction of the Owner or Separate Contractors by cutting, patching, or otherwise altering such construction, or by excavation. The Contractor shall not cut or otherwise alter construction by the Owner or a Separate Contractor except with written consent of the Owner

and of the Separate Contractor. Consent shall not be unreasonably withheld. The Contractor shall not unreasonably withhold, from the Owner or a Separate Contractor, its consent to cutting or otherwise altering the Work.

### **§ 3.15 Cleaning Up**

**§ 3.15.1** The Contractor shall keep the premises and surrounding area free from accumulation of waste materials and rubbish caused by operations under the Contract. At completion of the Work, the Contractor shall remove waste materials, rubbish, the Contractor's tools, construction equipment, machinery, and surplus materials from and about the Project. Contractor to be in compliance with Section 6002 of the Solid Waste Disposal Act as amended by Resource Conservation & Recovery Act, and related regulations.

**§ 3.15.2** If the Contractor fails to clean up as provided in the Contract Documents, the Owner may do so and the Owner shall be entitled to reimbursement from the Contractor.

### **§ 3.16 Access to Work**

The Contractor shall provide the Owner and Designer with access to the Work in preparation and progress wherever located.

### **§ 3.17 Royalties, Patents and Copyrights**

The Contractor shall pay all royalties and license fees. The Contractor shall defend suits or claims for infringement of copyrights and patent rights and shall hold the Owner harmless from loss on account thereof, but shall not be responsible for defense or loss when a particular design, process, or product of a particular manufacturer or manufacturers is required by the Contract Documents, or where the copyright violations are contained in Drawings, Specifications, or other documents prepared by the Owner. However, if an infringement of a copyright or patent is discovered by, or made known to, the Contractor, the Contractor shall be responsible for the loss unless the information is promptly furnished to the Owner. Contractor shall comply with the Right of Inventions Act (35 U.S.C. 202 through 204 and 37 CFR Part 401).

### **§ 3.18 Indemnification**

**§ 3.18.1** To the fullest extent permitted by law the Contractor hereby agrees to indemnify and hold harmless the KCHA, its successors and assigns, directors, officials, officers and employees, volunteers, partners and agents (all foregoing singly and collectively "Indemnitees"), from and against any and all claims losses, harm, costs, liabilities, damages and expenses including, but not limited to, reasonable attorneys' fees arising or resulting from the performance of the Work, or the acts or omissions of the Contractor its successors and assigns, employees, subcontractors or anyone acting on the Contractor's behalf in connection with this Contract or its performance; PROVIDED, however, that the Contractor shall not be required to so indemnify any such Indemnitees against liability for damages caused by or resulting from the sole negligence of Indemnitees; PROVIDED FURTHER that if such damages are caused by or result from the concurrent negligence of the Indemnitees and the Contractor or anyone acting on the Contractor's behalf, then the Contractor's indemnity hereunder shall be limited to the extent of the negligence of the Contractor, its successors and assigns, et al.

**§ 3.18.2** FURTHERMORE, the Contractor acknowledges that the foregoing indemnity is specifically and expressly intended to constitute waiver of the Contractor immunity under Washington's Industrial Act, RCW Title 51, and that this waiver has been specifically negotiated and agreed upon by the parties.

**§ 3.18.3** In claims against any person or entity indemnified under this Section 3.18 by an employee of the Contractor, a Subcontractor, anyone directly or indirectly employed by them, or anyone for whose acts they may be liable, the indemnification obligation under Section 3.18.1 shall not be limited by a limitation on amount or type of damages, compensation, or benefits payable by or for the Contractor or a Subcontractor under workers' compensation acts, disability benefit acts, or other employee benefit acts.

**§ 3.18.4** The Contractor hereby agrees to require all its subcontractors or anyone acting under its direction or control or on its behalf in connection with or incidental to the performance of this Contract to execute an indemnity clause identical to the preceding clause, specifically naming KCHA as Indemnitee, and failure to do so shall constitute a material breach of this Contract by the Contractor.

## **ARTICLE 4 DESIGNER; OWNER ADMINISTRATION OF CONTRACT**

### **§ 4.1 General**

**§ 4.1.1** The Designer is the person or entity retained by the Owner pursuant to Section 2.2.2 and identified as such in the Agreement.

**§ 4.1.2** Duties, responsibilities, and limitations of authority of the Designer as set forth in the Contract Documents shall not be restricted, modified, or extended without written consent of the Owner, Contractor, and Designer. Consent shall not be unreasonably withheld.

#### **§ 4.2 Administration of the Contract by Owner**

**§ 4.2.1** The Owner will provide administration of the Contract as described in the Contract Documents.

**§ 4.2.2** The Owner may visit the site to inspect the progress and quality of the portion of the Work completed, and to determine in general if the Work observed is being performed in a manner indicating that the Work, when fully completed, will be in accordance with the Contract Documents. The Owner will not be required to make exhaustive or continuous on-site inspections to check the quality or quantity of the Work. The Owner will not have control over, charge of, or responsibility for the construction means, methods, techniques, sequences or procedures, or for the safety precautions and programs in connection with the Work, since these are solely the Contractor's rights and responsibilities under the Contract Documents except as provided in section 3.3.1.

**§ 4.2.3** On the basis of the site visits, the Owner will identify (1) known deviations from the Contract Documents, (2) known deviations from the most recent Master Project Schedule submitted by the Contractor, and (3) defects and deficiencies observed in the Work. The Owner will not be responsible for the Contractor's failure to perform the Work in accordance with the requirements of the Contract Documents. The Owner will not have control over or charge of, and will not be responsible for acts or omissions of, the Contractor, Subcontractors, or their agents or employees, or any other persons or entities performing portions of the Work.

#### **§ 4.2.4 Communications**

Except as otherwise provided in the Contract Documents, the Owner and Contractor shall endeavor to communicate with each other directly about matters arising out of or relating to the Contract. Communications by and with the Designer and other consultants shall be through the Owner unless Owner directs otherwise. Communications by and with Subcontractors, Lower-Tier Subcontractors, and suppliers shall be through the Contractor. Communications by and with Separate Contractors shall be through the Owner. The Contract Documents may specify other communication protocols.

**§ 4.2.5** The Owner will evaluate Contractor's Applications for Payment and will pay such amounts as properly requested by Contractor, subject to any deductions, offsets, or withholdings, as specified in the Contract Documents.

**§ 4.2.6** The Owner has authority to reject Work that does not conform to the Contract Documents. Whenever the Owner considers it necessary or advisable, the Owner will have authority to require inspection or testing of the Work in accordance with Sections 13.4.2 and 13.4.3, whether or not the Work is fabricated, installed or completed. However, neither this authority of the Owner nor a decision made in good faith either to exercise or not to exercise such authority shall give rise to a duty or responsibility of the Owner to the Contractor, Subcontractors, Lower-Tier Subcontractors, suppliers, their agents or employees, or other persons or entities performing portions of the Work.

**§ 4.2.7** The Owner and/or Designer will review and approve, or take other appropriate action upon, the Contractor's submittals such as Shop Drawings, Product Data, and Samples, but only for the limited purpose of checking for conformance with information given and the design concept expressed in the Contract Documents. The Owner and/or Designer's action will be taken in accordance with the submittal schedule approved by the Owner or, in the absence of an approved submittal schedule, with reasonable promptness while allowing sufficient time in the Owner's reasonable judgment to permit adequate review. Review of such submittals is not conducted for the purpose of determining the accuracy and completeness of other details such as dimensions and quantities, or for substantiating instructions for installation or performance of equipment or systems, all of which remain the responsibility of the Contractor as required by the Contract Documents. The Owner's review of the Contractor's submittals shall not relieve the Contractor of the obligations under Sections 3.3, 3.5, and 3.12. The Owner and/or Designer's review shall not constitute approval of safety precautions or of any construction means, methods, techniques, sequences, or procedures. The Owner's and/or Designer's approval of a specific item shall not indicate approval of an assembly of which the item is a component.

**§ 4.2.8** The Owner will prepare Change Orders and Construction Change Directives, and may order minor changes in the Work as provided in Section 7.4. The Owner will investigate and make determinations and recommendations regarding concealed and unknown conditions as provided in Section 3.7.4.

§ 4.2.9 The Owner will conduct inspections to determine the date or dates of Substantial Completion and the date of final completion; issue Certificates of Substantial Completion pursuant to Section 9.8; and issue a final payment pursuant to Section 9.10.

§ 4.2.10 The Designer may assist the Owner with inspections and substantial completion certification.

§ 4.2.11 The Owner will interpret and decide matters concerning performance under, and requirements of, the Contract Documents. If the Contractor disputes the Owner's determination, the Contractor may submit a Claim as provided in Article 15.

§ 4.2.12 Interpretations and decisions of the Owner will be consistent with the intent of, and reasonably inferable from, the Contract Documents and will be in writing or in the form of drawings.

§ 4.2.13 The Owner's decisions on matters relating to aesthetic effect will be final if consistent with the intent expressed in the Contract Documents.

§ 4.2.14 The Owner will review and respond to requests for information about the Contract Documents. The Owner's response to such requests will be made in writing within any time limits agreed upon or otherwise with reasonable promptness. If appropriate, the Designer will assist the Owner and respond to Requests For Information (RFIs) within no more than 14 calendar days.

## **ARTICLE 5 SUBCONTRACTORS**

### **§ 5.1 Definitions**

§ 5.1.1 A Subcontractor is a person or entity who has a direct contract with the Contractor to perform a portion of the Work at the site. The term "Subcontractor" is referred to throughout the Contract Documents as if singular in number and means a Subcontractor or an authorized representative of the Subcontractor. The term "Subcontractor" does not include a Separate Contractor or the subcontractors of a Separate Contractor.

§ 5.1.2 A Lower-Tier Subcontractor is a person or entity who has a direct or indirect contract with a Subcontractor to perform a portion of the Work at the site. The term "Lower-Tier Subcontractor" is referred to throughout the Contract Documents as if singular in number and means a Lower-Tier Subcontractor or an authorized representative of the Lower-Tier Subcontractor.

### **§ 5.2 Award of Subcontracts and Other Contracts for Portions of the Work**

§ 5.2.1 Unless otherwise stated in the Contract Documents or the bidding requirements, the Contractor, as soon as practicable after award of the Contract, shall notify the Owner of the persons or entities for each principal portion of the Work, including those who are to furnish materials or equipment fabricated to a special design as identified in the Bid Documents. Within 14 calendar days of receipt of the information, the Owner may notify the Contractor whether the Owner (1) has reasonable objection to any such proposed person or entity or (2) requires additional time for review. Failure of the Owner to provide notice within the 14 calendar-day period shall constitute notice of no reasonable objection, but no failure to provide such notice shall be deemed a waiver of any requirements of the Contract Documents.

§ 5.2.2 The Contractor shall not contract with a proposed person or entity to whom the Owner has made reasonable and timely objection. Except as otherwise provided in the Contract Documents, the Contractor shall not be required to contract with anyone to whom the Contractor has made reasonable objection. The Contractor shall ensure that all and any Subcontractors and Lower-Tier Subcontractors are not on any Debarment Lists and are not excluded from performing work on federally funded projects.

§ 5.2.3 If the Owner has reasonable objection to a person or entity proposed by the Contractor, the Contractor shall propose another to whom the Owner has no reasonable objection. If the proposed but rejected Subcontractor was reasonably capable of performing the Work, the Contract Sum and Contract Time shall be increased or decreased by the difference, if any, occasioned by such change, and an appropriate Change Order shall be issued before commencement of the substitute Subcontractor's Work. However, no increase in the Contract Sum or Contract Time shall be allowed for such change unless the Contractor has acted promptly and responsively in submitting names as required.

§ 5.2.4 The Contractor shall not substitute a Subcontractor, person, or entity for one previously selected if the Owner makes reasonable objection to such substitution.

**§ 5.2.5** The Contractor shall ensure that whenever possible subcontracts are awarded to small business firms, minority business firms, women business firms, and labor surplus area firms per 24 CFR Part 75.

**§ 5.2.6** The Contractor shall comply with Executive Order 11246 as amended, and the rules, regulations, and orders of the Secretary of Labor in relation to Equal Opportunity Employment.

**§ 5.2.7** The Contractor shall also comply with the provisions of Section 3 of the Housing and Urban Development Act of 1968, as amended, 12 USC 1701(u) (Section 3) as implemented by HUD under 24 CFR Part 75, for employment, training, and contracting opportunities for low-income persons.

### **§ 5.3 Sub-contractual Relations**

By appropriate written agreement, the Contractor shall require each Subcontractor, to the extent of the Work to be performed by the Subcontractor, to be bound to the Contractor by terms of the Contract Documents, and to assume toward the Contractor all the obligations and responsibilities, including the responsibility for safety of the Subcontractor's Work that the Contractor, by these Contract Documents, assumes toward the Owner. Each subcontract agreement shall preserve and protect the rights of the Owner under the Contract Documents with respect to the Work to be performed by the Subcontractor so that subcontracting thereof will not prejudice such rights, and shall allow to the Subcontractor, unless specifically provided otherwise in the subcontract agreement, the benefit of all rights, remedies, and redress against the Contractor that the Contractor, by the Contract Documents, has against the Owner. Where appropriate, the Contractor shall require each Subcontractor to enter into similar agreements with Lower-Tier Subcontractors. The Contractor shall make available to each proposed Subcontractor, prior to the execution of the subcontract agreement, copies of the Contract Documents to which the Subcontractor will be bound, and, upon written request of the Subcontractor, identify to the Subcontractor terms and conditions of the proposed subcontract agreement that may be at variance with the Contract Documents. Subcontractors will similarly make copies of applicable portions of such documents available to their respective proposed Lower-Tier Subcontractors.

### **§ 5.4 Contingent Assignment of Subcontracts**

**§ 5.4.1** Each subcontract agreement for a portion of the Work is assigned by the Contractor to the Owner, provided that

- .1 assignment is effective only after termination of the Contract by the Owner for cause pursuant to Section 14.2 and only for those subcontract agreements that the Owner accepts by notifying the Subcontractor and Contractor; and
- .2 assignment is subject to the prior rights of the surety, if any, obligated under bond relating to the Contract.

When the Owner accepts the assignment of a subcontract agreement, the Owner assumes the Contractor's rights and obligations under the subcontract.

**§ 5.4.2** Upon such assignment, if the Work has been suspended for more than 30 days, the Subcontractor's compensation shall be equitably adjusted for increases in cost resulting from the suspension.

**§ 5.4.3** Upon assignment to the Owner under this Section 5.4, the Owner may further assign the subcontract to a successor contractor or other entity. If the Owner assigns the subcontract to a successor contractor or other entity, the Owner shall nevertheless remain legally responsible for all of the successor contractor's obligations under the subcontract.

## **ARTICLE 6 CONSTRUCTION BY OWNER OR BY SEPARATE CONTRACTORS**

### **§ 6.1 Owner's Right to Perform Construction and to Award Separate Contracts**

**§ 6.1.1** The term "Separate Contractor(s)" shall mean other contractors retained by the Owner under separate agreements. The Owner reserves the right to perform construction or operations related to the Project with the Owner's own forces, and with Separate Contractors retained under Conditions of the Contract substantially similar to those of this Contract, including those provisions of the Conditions of the Contract related to insurance and waiver of subrogation. If the Contractor claims that delay or additional cost is involved because of such action by the Owner, the Contractor shall make such Claim as provided in Article 15.

**§ 6.1.2** When separate contracts are awarded for different portions of the Project or other construction or operations on the site, the term "Contractor" in the Contract Documents in each case shall mean the Contractor who executes each separate Owner-Contractor Agreement.

**§ 6.1.3** The Owner shall provide for coordination of the activities of the Owner's own forces and of each Separate Contractor with the Work of the Contractor, who shall cooperate with them. The Contractor shall participate with any Separate Contractors

and the Owner in reviewing their Master Project Schedule. The Contractor shall make any revisions to its Master Project Schedule deemed necessary after a joint review and mutual agreement. The Master Project Schedule shall then constitute the schedule to be used by the Contractor, Separate Contractors, and the Owner until subsequently revised.

**§ 6.1.4** Unless otherwise provided in the Contract Documents, when the Owner performs construction or operations related to the Project with the Owner's own forces or with Separate Contractors, the Owner or its Separate Contractors shall have the same obligations and rights that the Contractor has under the Conditions of the Contract, including, without excluding others, those stated in Article 3, this Article 6, and Articles 10, 11, and 12.

## **§ 6.2 Mutual Responsibility**

**§ 6.2.1** The Contractor shall afford the Owner and Separate Contractors reasonable opportunity for introduction and storage of their materials and equipment and performance of their activities, and shall connect and coordinate the Contractor's construction and operations with theirs as required by the Contract Documents.

**§ 6.2.2** If part of the Contractor's Work depends for proper execution or results upon construction or operations by the Owner or a Separate Contractor, the Contractor shall, prior to proceeding with that portion of the Work, promptly notify the Owner of apparent discrepancies or defects in the construction or operations by the Owner or Separate Contractor that would render it unsuitable for proper execution and results of the Contractor's Work. Failure of the Contractor to notify the Owner of apparent discrepancies or defects prior to proceeding with the Work shall constitute an acknowledgment that the Owner's or Separate Contractor's completed or partially completed construction is fit and proper to receive the Contractor's Work. The Contractor shall not be responsible for discrepancies or defects in the construction or operations by the Owner or Separate Contractor that are not apparent.

**§ 6.2.3** The Contractor shall reimburse the Owner for costs the Owner incurs that are payable to a Separate Contractor because of the Contractor's delays, improperly timed activities or defective construction. The Owner shall be responsible to the Contractor for costs the Contractor incurs because of a Separate Contractor's delays, improperly timed activities, damage to the Work or defective construction.

**§ 6.2.4** The Contractor shall promptly remedy damage that the Contractor wrongfully causes to completed or partially completed construction or to property of the Owner or Separate Contractor as provided in Section 10.2.5.

**§ 6.2.5** The Owner and each Separate Contractor shall have the same responsibilities for cutting and patching as are described for the Contractor in Section 3.14.

**§ 6.2.6** The Contractor is obligated to comply with all Davis-Bacon and/or State prevailing-wage and other public works regulations if applicable, and shall inform all Subcontractors and Lower-Tier Subcontractors of this mandatory requirement. Strict compliance with all applicable requirements concerning certified payrolls and monitoring of that compliance is a direct responsibility of the Contractor for each Subcontractor and Lower-Tier Subcontractor. Without limiting the extent of Contractor's responsibility, failure of the Contractor to monitor compliance with applicable requirements, including certified payroll compliance by Subcontractors and Lower-Tier Subcontractors, as evidenced by the Owner's review and written correction notices provided to the Contractor of non-compliance, will result in delay of progress payments to the Contractor by the Owner.

## **§ 6.3 Owner's Right to Clean Up**

If a dispute arises among the Contractor, Separate Contractors, and the Owner as to the responsibility under their respective contracts for maintaining the premises and surrounding area free from waste materials and rubbish, the Owner may clean up and the Owner will allocate the cost among those responsible.

## **ARTICLE 7 CHANGES IN THE WORK**

### **§ 7.1 General**

**§ 7.1.1** Changes in the Work may be accomplished after execution of the Contract, and without invalidating the Contract, by Construction Change Directive (CCD), Change Order (CO), or Change Order Request (COR), subject to the limitations stated in this Article 7 and elsewhere in the Contract Documents.

All changes in the Work shall be completed for a fixed fee.

#### **.1 Overhead, Profit, and General Conditions**

- (a.) The allowed markup shall cover all indirect project costs, including but not limited to: project Overhead, Profit, and General Conditions
  - (b.) The Contractor shall be allowed a maximum of 14% Overhead, Profit, and General Conditions, on the cost of craft labor, equipment, small tools and materials for self-performed Change Order work. All General Conditions need to be approved by Owner before they are applied.
  - (c.) The Contractor shall be allowed a maximum of 8% Overhead, Profit, and General Conditions on the cost of craft labor, equipment, small tools and materials for Subcontractor Change Order work. The Contractor is not allowed to take a profit on the profit of the Subcontractor.
  - (d.) A Subcontractor shall be allowed a maximum of 14% of the cost of craft labor, equipment, materials, and small tools for Overhead and Profit, for performing self- performed Change Order work.
  - (e.) A Lower Tier Subcontractor shall be allowed a maximum of 14% of the cost of craft labor, equipment, materials, and small tools for Overhead and Profit, for performing Change Order work.
- .2 The Owner anticipates that it will desire the Contractor to accomplish Work that was not able to be reasonably defined in sufficient detail during the solicitation for Bids for this Project (such additional Work defined as the “Owner Directed Work”). The Contractor agrees to perform such Owner Directed Work in accordance as authorized in either CCD, COR or CO.
  - .3 A fixed sum has been determined by the Owner for each individual and separate Owner Directed Work item. The total Contract Amount includes the lump sum total of all combined Owner Directed Work items. It is at the sole discretion and decision of the Owner to authorize the Contractor to proceed with each individual Owner Directed Work item. If any or all Owner Directed Work items are determined to be excluded from the Work, the Owner will provide a Change Order to the Contractor to deduct those amounts from the Contract.
  - .4 If any or all Owner Directed Work Items are authorized by the Owner to be completed, the Owner will issue an “Owner Directed Work Order” to the Contractor for that Work item.
  - .5 For each Owner Directed Work Order issued by the Owner, the Contractor shall provide a complete and detailed cost estimate for that item to the Owner. The Contractor’s estimate shall be approved by the Owner, prior to the commencement of any Owner Directed Work. Adjustments to the Contract may be made as an additive or deductive Change Order as determined by the difference between the Owner Directed Work Item Allowance, the final approved estimated cost as submitted by the Contractor, and the final analysis of the cost as conducted by the Owner.
  - .6 The Contractor shall provide a complete and accurate time and material account report to the Owner for each issued work authorization for each Owner Directed Work item as well as any other documentation Owner may require.
  - .7 Owner Directed Work items are defined in the Contract Documents.

**§ 7.1.2 The Contractor, Subcontractor(s), and all Lower Tier Subcontractors shall not be entitled to any compensation, however characterized, for preparation of estimates or other documents related to CCDs, CORs, or COs.**

§ 7.1.3 All CCDs, CORs, and COs shall be made on such forms, and subject to such requirements, as provided in the Contract Documents.

**§ 7.2 Construction Change Directives**

**§ 7.2.1**

The Owner may by Construction Change Directive, without invalidating the Contract, order changes in the Work within the general scope of the Contract consisting of additions, deletions or other revisions, the Contract Sum and Contract Time being adjusted accordingly.

A Construction Change Directive (CCD), also called a “Force Account Work”, is an alternative mechanism for directing the Contractor to perform additional work to the Contract when specifics of time and/or cost of the work are not finalized between the Owner and the Contractor performing the work. Typically, Owner will issue a CCD written as a “not to exceed” amount. The transaction would be structured on a Time and Material (T&M) basis for the work requested. Owner will request labor rates, equipment rates, and any other information relevant to the work, prior to the start of any work in question. The Contractor will then give Owner a Rough Order of Magnitude (ROM) estimate and follow up with the appropriate back up documentation once the work has been completed. Owner will review the documentation and compare them against Owner’s observations/dailies to verify that the time and materials are just and equitable.

**§ 7.2.2** A Construction Change Directive shall be used in the absence of total agreement on the terms of a Change Order and shall be in the form attached as an Exhibit to the Agreement.

**§ 7.2.3** If the Construction Change Directive provides for an adjustment to the Contract Sum, the adjustment shall be based on one of the following methods:

- .1 Mutual acceptance of a lump sum properly itemized and supported by sufficient substantiating data to permit evaluation;
- .2 Unit prices stated in the Contract Documents or subsequently agreed upon;
- .3 Cost to be determined in a manner agreed upon by the parties and a mutually acceptable fixed or percentage fee; or
- .4 As provided in Section 7.3.4.

**§ 7.2.4** Upon receipt of a Construction Change Directive, the Contractor shall promptly proceed with the change in the Work involved and advise the Owner of the Contractor's agreement or disagreement with the method, if any, provided in the Construction Change Directive for determining the proposed adjustment in the Contract Sum or Contract Time and shall include such detail and supporting documents as may be required by Owner to evaluate the basis for Contractor's disagreement, if any.

**§ 7.2.5** A Construction Change Directive signed by the Contractor indicates the Contractor's agreement therewith, including adjustment in Contract Sum and Contract Time or the method for determining them. Such agreement shall be effective immediately and shall be recorded either as a COR or a Change Order.

### **§ 7.3 Change Order Requests**

**§ 7.3.1** A Change Order Request (COR) is issued when work is added to or deleted from the original Scope of Work in the Contract. A COR, once approved, will be charged against the Owner's Contingency and will not change the Contract Sum. Once the Owner's Contingency is exhausted the COR will become a Change Order (CO), and a CO will then be used to change the Contract Sum. A COR is executed in the same manner as a CO, except this work is funded specifically from the Owner's Contingency set forth in the Bid Documents.

The COR is prepared by the Owner based upon Owner-accepted COR Breakdown Summaries supplied by the Contractor, Subcontractor(s) and Lower-Tier Subcontractor(s).

**§ 7.3.2** The Contractor may include in its Applications for Payment requests for payment for Work completed under CORs.

**§ 7.3.3** The Contractor, Subcontractor(s), and all Lower Tier Subcontractors shall not charge a Fee, Salaries, or other compensation for preparation of Change Order Requests.

**§ 7.3.4** If the Contractor does not respond promptly or disagrees with the method for adjustment in the Change Order Request, the Owner shall determine the adjustment on the basis of reasonable expenditures and savings of those performing the Work attributable to the change, including, an amount for overhead and profit as set forth in the Agreement, or if no such amount is set forth in the Agreement, a reasonable amount. In such case, the Contractor shall keep and present, in such form as the Owner may prescribe, an itemized accounting together with appropriate supporting data. Unless otherwise provided in the Contract Documents, costs for the purposes of this Section 7.3.4 shall be limited to the following:

- .1 Costs of labor, including applicable payroll taxes, fringe benefits required by agreement or custom, workers' compensation insurance, and other employee costs approved by the Owner;
- .2 Costs of materials, supplies, and equipment, including cost of transportation, whether incorporated or consumed;
- .3 Rental costs of machinery and equipment, exclusive of hand tools, whether rented from the Contractor or others;
- .4 Costs of premiums for all bonds and insurance, permit fees, and sales, use, or similar taxes, directly related to the change; and
- .5 Costs of supervision and field office personnel directly attributable to the change.

If the Contractor disagrees with the Owner's determination under this Section, then Contractor may make a Claim in accordance with applicable provisions of Article 15.

### **§ 7.4 Change Orders**

**§ 7.4.1** A Change Order is a formal written instrument prepared by the Owner and signed by the Owner and Contractor stating their agreement upon all of the following:

- .1 The change in the Work;
- .2 The amount of the adjustment, if any, in the Contract Sum; and
- .3 The extent of the adjustment, if any, in the Contract Time.

**§ 7.4.2** A Change Order shall be based upon agreement between the Owner and Contractor.

**§ 7.4.3** Changes in the Work shall be performed under applicable provisions of the Contract Documents. The Contractor shall proceed promptly with changes in the Work, unless otherwise provided in the Change Order.

**§ 7.4.4** The amount of credit to be allowed by the Contractor to the Owner for a deletion or change that results in a net decrease in the Contract Sum shall be actual net cost as confirmed by the Owner. When both additions and credits covering related Work or substitutions are involved in a change, the allowance for overhead and profit shall be figured on the basis of the net increase, if any, with respect to that change.

**§ 7.4.5** When the Owner and Contractor agree with a determination made concerning the adjustments in the Contract Sum and Contract Time, or otherwise reach agreement upon the adjustments, such agreement shall be effective immediately and the Owner will prepare a Change Order for signature by Owner and Contractor.

**§ 7.4.6** If the Contractor disagrees with the adjustment in the Contract Time or Contract Amount, the Contractor may make a Claim in accordance with applicable provisions of Article 15.

### **§ 7.5 Minor Changes in the Work**

The Owner may order minor changes in the Work that are consistent with the intent of the Contract Documents and do not involve an adjustment in the Contract Sum or an extension of the Contract Time. The Owner's order for minor changes shall be in writing. If the Contractor believes that the proposed minor change in the Work will affect the Contract Sum or Contract Time, the Contractor shall notify the Owner and shall not proceed to implement the change in the Work unless directed otherwise by CCD. If the Contractor performs the Work set forth in the Owner's order for a minor change without prior notice to the Owner that such change will affect the Contract Sum or Contract Time, the Contractor waives any adjustment to the Contract Sum or extension of the Contract Time.

## **ARTICLE 8 TIME**

### **§ 8.1 Definitions**

**§ 8.1.1** Unless otherwise provided, Contract Time is the period of time, including authorized adjustments, allotted in the Contract Documents for Substantial Completion of the Work.

**§ 8.1.2** The date of commencement of the Work is the date established in the Agreement.

**§ 8.1.3** The date of Substantial Completion is the date determined by the Owner in accordance with Section 9.7.

**§ 8.1.4** The term "day" as used in the Contract Documents shall mean calendar day unless otherwise specifically defined.

### **§ 8.2 Progress and Completion**

**§ 8.2.1** Time limits stated in the Contract Documents are of the essence of the Contract. By executing the Agreement, the Contractor confirms that the Contract Time is a reasonable period for performing the Work.

**§ 8.2.2** The Contractor shall not knowingly, except by agreement or instruction of the Owner in writing, commence the Work at the Project site prior to the effective date of insurance required by Article 11 to be furnished by the Contractor and Owner. The date of commencement of the Work shall not be changed by the effective date of such insurance.

**§ 8.2.3** The Contractor shall proceed expeditiously with adequate forces and shall achieve Substantial Completion within the Contract Time.

### **§ 8.3 Delays and Extensions of Time**

**§ 8.3.1** If the Contractor is delayed at any time in the commencement or progress of the Work by (1) an act or neglect of the Owner or Designer, of an employee of either, or of a Separate Contractor; (2) by changes ordered in the Work; (3) by labor disputes, fire, unusual delay in deliveries, unavoidable casualties, adverse weather conditions documented in accordance with Section 15.1.6.2, or other causes beyond the Contractor's control; (4) by delay authorized by the Owner pending mediation and binding dispute resolution; or (5) by other causes that the Contractor asserts, and the Owner determines, justify delay, then the Contract Time shall be extended for such reasonable time as the Owner may determine.

**§ 8.3.2** Claims relating to time shall be made in accordance with applicable provisions of Article 15.

**§ 8.3.3** This Section 8.3 does not preclude recovery of damages for delay by either party under other provisions of the Contract Documents.

## **ARTICLE 9 PAYMENTS AND COMPLETION**

### **§ 9.1 Contract Sum**

**§ 9.1.1** The Contract Sum is stated in the Agreement and, including authorized adjustments, is the total amount payable by the Owner to the Contractor for performance of the Work under the Contract Documents.

**§ 9.1.2** If unit prices are stated in the Contract Documents or subsequently agreed upon, and if quantities originally contemplated are materially changed so that application of such unit prices to the actual quantities causes substantial inequity to the Owner or Contractor, the applicable unit prices shall be equitably adjusted.

### **§ 9.2 Schedule of Values**

Where the Contract is based on a stipulated sum or Guaranteed Maximum Price, the Contractor shall submit a schedule of values to the Owner before the first Application for Payment, allocating the entire Contract Sum to the various portions of the Work. The schedule of values shall be prepared in the form, and supported by the data to substantiate its accuracy, required by the Owner. This schedule, which such revisions as may be reasonably required by Owner, shall be used as a basis for reviewing the Contractor's Applications for Payment. Any changes to the schedule of values shall be submitted to the Owner and supported by such data to substantiate its accuracy as the Owner may require, and unless objected to by the Owner, shall be used as a basis for reviewing the Contractor's subsequent Applications for Payment. The schedule of values must correlate to the Master Project Schedule and contain a line item showing the value for the closeout documents. If Contractor disputes the Owner's decision to require a change to the schedule of values or to reject a change proposed by the Contractor, then Contractor may submit a Claim in accordance with Article 15.

### **§ 9.3 Applications for Payment**

**§ 9.3.1** At least fourteen calendar days before the date established for each progress payment, the Contractor shall submit to the Owner an itemized Application for Payment using AIA Form G701 and AIA Form G702 prepared in accordance with Article 5 of the Agreement and the schedule of values under Section 9.2, for completed portions of the Work. The application shall be notarized, if required, and supported by all data substantiating the Contractor's right to payment that the Owner require, such as copies of requisitions, and releases and waivers of liens from Subcontractors, Lower-Tier Subcontractors, and suppliers, and shall reflect retainage if provided for in the Contract Documents.

**§ 9.3.1.1** As provided in Section 9.2, such applications may include requests for payment on account of changes in the Work that have been properly authorized by Construction Change Directives.

**§ 9.3.1.2** Applications for Payment shall not include requests for payment for portions of the Work for which the Contractor does not intend to pay a Subcontractor or supplier, unless such Work has been performed by others whom the Contractor intends to pay.

**§ 9.3.2** Unless otherwise provided in the Contract Documents, payments shall be made on account of materials and equipment delivered and suitably stored at the site for subsequent incorporation in the Work. If approved in advance by the Owner, payment may similarly be made for materials and equipment suitably stored off the site at a location agreed upon in writing. Payment for materials and equipment stored on or off the site shall be conditioned upon compliance by the Contractor with procedures satisfactory to the Owner to establish the Owner's title to such materials and equipment or otherwise protect the Owner's interest, and shall include the costs of applicable insurance, storage, and transportation to the site, for such materials and equipment stored off the site.

**§ 9.3.3** The Contractor warrants that title to all Work covered by an Application for Payment will pass to the Owner no later than the time of payment. Each Application for Payment shall be accompanied by a signed and notarized General Contractor Certificate Upon Application for Payment, by which Contractor shall warrant that upon submittal of the Application for Payment all Work for which Applications for Payment have been previously issued and payments received from the Owner shall be free and clear of liens, claims, security interests, or encumbrances, in favor of the Contractor, Subcontractors, Lower-Tier Subcontractors, suppliers, or other persons or entities that provided labor, materials, and equipment relating to the Work.

## § 9.4 Decisions to Withhold Payment

§ 9.4.1 The Owner may withhold Payment in whole or in part, to the extent reasonably necessary to protect the Owner, if in the Owner's opinion the representations to the Owner required by Section 9.4.2 cannot be made. If the Owner will not make payment in the amount of the Application, the Owner will promptly notify the Contractor. If the Contractor and Owner cannot agree on a revised amount, the Owner will promptly release Payment for the amount for any agreed-upon portion of the amount requested by Contractor. The Owner may also deny an Application for Payment in whole or in part or, because of subsequently discovered evidence, may rescind approval of an Application for Payment previously issued, in whole or in part, to such extent as may be necessary in the Owner's opinion to protect the Owner from loss for which the Contractor is responsible, including loss resulting from acts and omissions described in Section 3.3.2, because of:

- .1 Suspension/expiration of WA State Contractor's License;
- .2 Any Federal and/or State Liens against the Contractor, Contractor's bond(s) including any payment and performance bond, or the retention;
- .3 Defective Work not accepted;
- .4 Defective Work not remedied;
- .5 Work not approved;
- .6 Third party claims filed or reasonable evidence indicating probable filing of such claims unless security acceptable to the Owner is provided by the Contractor;
- .7 Failure of the Contractor to make payments properly to Subcontractors, Lower-Tier Subcontractors, or suppliers for labor, materials or equipment;
- .8 Damage to the Owner or a separate contractor;
- .9 Non-submittal of Certified Payrolls (by Contractor and all Subcontractors and Lower-Tier Subcontractors);
- .10 **Non-compliance with weekly Certified Payroll Reports:**
  - .a Restitution of workers;
  - .b Incomplete or inaccurate payrolls;
- .11 Failure to file required Statement of Intent or Affidavit of Wages Paid with the Washington State Department of Labor and Industries or failure to comply with such documents;
- .12 Expiration, cancellation, or reduction of required insurance;
- .13 Incorrect or incomplete Application for Payment, including failure to provide required lien release(s) and Contractor Certification Upon Application for Payment;
- .14 Repeated safety violations;
- .15 Failure to update the As-Built Documents in accordance with the Scope of Work;
- .16 Reasonable evidence that the work will not be completed within the Contract Time, and that the unpaid balance would not be adequate to cover actual or liquidated damages for the anticipated delay;
- .17 Repeated failure to carry out the Work in accordance with the Contract Documents; or
- .18 **Non-compliance with Section 3 reporting.**

§ 9.4.2 When Contractor disputes the Owner's decision regarding an Application for Payment under Section 9.4.1, in whole or in part, Contractor may submit a Claim in accordance with Article 15.

§ 9.4.3 When the reasons for withholding payments are removed, payment will be made for amounts previously withheld.

§ 9.4.4 If the Owner withholds payment under Section 9.4.1.7, the Owner may, at its sole option, issue joint checks to the Contractor and to any Subcontractor or supplier to whom the Contractor failed to make payment for Work properly performed or material or equipment suitably delivered. If the Owner makes payments by joint check, the Owner shall notify and the Contractor shall reflect such payment on its next Application for Payment.

## § 9.5 Progress Payments

§ 9.5.1 After the Owner has approved an Application for Payment, the Owner shall make payment in the manner and within the time provided in the Contract Documents.

§ 9.5.2 The Contractor shall pay each Subcontractor, no later than seven days after receipt of payment from the Owner, the amount to which the Subcontractor is entitled, reflecting percentages actually retained from payments to the Contractor on account of the Subcontractor's portion of the Work. The Contractor shall, by appropriate agreement with each Subcontractor, require each Subcontractor to make payments to Lower Tier Subcontractors in a similar manner.

**§ 9.5.3** The Owner will, on request, furnish to a Subcontractor, if practicable, information regarding percentages of completion or amounts applied for by the Contractor and action taken thereon by the Owner on account of portions of the Work done by such Subcontractor.

**§ 9.5.4** The Owner has the right to request written evidence from the Contractor that the Contractor has properly paid Subcontractors and suppliers amounts paid by the Owner to the Contractor for subcontracted Work. If the Contractor fails to furnish such evidence within seven days, the Owner shall have the right to contact Subcontractors and suppliers to ascertain whether they have been properly paid. The Owner shall have no obligation to pay, or to see to the payment of money to, a Subcontractor or supplier, except as may otherwise be required by law.

**§ 9.5.5** The Contractor's payments to suppliers shall be treated in a manner similar to that provided in Sections 9.5.2, 9.5.3 and 9.5.4.

**§ 9.5.6** An approval of an Application for Payment, a progress payment, or partial or entire use or occupancy of the Project by the Owner shall not constitute acceptance of Work not in accordance with the Contract Documents.

**§ 9.5.7** Unless the Contractor provides the Owner with a payment bond in the full penal sum of the Contract Sum, payments received by the Contractor for Work properly performed by Subcontractors or provided by suppliers shall be held by the Contractor for those Subcontractors or suppliers who performed Work or furnished materials, or both, under contract with the Contractor for which payment was made by the Owner. Nothing contained herein shall require money to be placed in a separate account and not commingled with money of the Contractor, create any fiduciary liability or tort liability on the part of the Contractor for breach of trust, or entitle any person or entity to an award of punitive damages against the Contractor for breach of the requirements of this provision.

**§ 9.5.8** Provided the Owner has fulfilled its payment obligations under the Contract Documents, the Contractor shall defend and indemnify the Owner from all loss, liability, damage or expense, including reasonable attorney's fees and litigation expenses, arising out of any lien claim or other claim for payment by any Subcontractor or supplier of any tier. Upon receipt of notice of a lien claim or other claim for payment, the Owner shall notify the Contractor. If approved by the applicable court, when required, the Contractor may substitute a surety bond for the property against which the lien or other claim for payment has been asserted.

## **§ 9.6 Failure of Payment**

If the Owner, through no fault of the Contractor, does not pay the Contractor within the date established in the Contract Documents, any undisputed amount owed to the Contractor and properly requested by the Contractor through an appropriate Application for Payment, then the Contractor may, upon seven additional days' notice to the Owner, stop the Work until payment of the amount owing has been received. The Contract Time shall be extended appropriately and the Contract Sum shall be increased by the amount of the Contractor's reasonable costs of shutdown, delay and start-up, plus interest as provided for in the Contract Documents. Contractor shall have no right to stop the Work under this Section to the event that there is a bona fide dispute over Contractor's right to payment.

## **§ 9.7 Substantial Completion**

**§ 9.7.1** Substantial Completion is the stage in the progress of the Work when the Work or designated portion thereof is sufficiently complete in accordance with the Contract Documents so that the Owner can occupy or utilize the Work for its intended use as reasonably determined by the Owner.

**§ 9.7.2** When the Contractor considers that the Work, or a portion thereof which the Owner agrees to accept separately, is substantially complete, the Contractor shall prepare and submit to the Owner a comprehensive list of items to be completed or corrected prior to final payment. Failure to include an item on such list does not alter the responsibility of the Contractor to complete all Work in accordance with the Contract Documents.

**§ 9.7.3** Upon receipt of the Contractor's list, the Owner will make an inspection to determine whether the Work or designated portion thereof is substantially complete. If the Owner's inspection discloses any item, whether or not included on the Contractor's list, which is not sufficiently complete in accordance with the Contract Documents so that the Owner can occupy or utilize the Work or designated portion thereof for its intended use, the Contractor shall, before issuance of the Certificate of Substantial Completion, complete or correct such item upon notification by the Owner. In such case, the Contractor shall then submit a request for another inspection by the Owner to determine Substantial Completion.

**§ 9.7.4** When the Owner reasonably believes that the Work or designated portion thereof is substantially complete, the Owner will prepare a Certificate of Substantial Completion that shall establish the date of Substantial Completion; establish responsibilities of the Owner and Contractor for security, maintenance, heat, utilities, damage to the Work and insurance; and fix the time within which the Contractor shall finish all items on the list accompanying the Certificate. Warranties required by the Contract Documents shall commence on the date of Substantial Completion of the Work or designated portion thereof unless otherwise provided in the Certificate of Substantial Completion. Issuance of a certificate of Substantial Completion shall not constitute a representation or warranty of any kind by Owner and shall not alter the responsibility of the Contractor to complete all Work in accordance with the Contract Documents.

**§ 9.7.5** The Certificate of Substantial Completion shall be submitted to the Contractor for written acceptance of responsibilities assigned in the Certificate.

**§ 9.7.6** Physical Completion occurs when the Contractor has completed or corrected all items identified on the comprehensive list developed under Section 9.7.2, the Owner has inspected and verified that all items have been completed or corrected in accordance with the Contract Documents and the Contractor and all Subcontractors and Lower-Tier Subcontractors have removed all construction equipment, excess materials, debris/rubbish, tools and will no longer return to the construction site.

### **§ 9.8 Partial Occupancy or Use**

**§ 9.8.1** The Owner may occupy or use any completed or partially completed portion of the Work at any stage when such portion is designated by separate agreement with the Contractor, provided such occupancy or use is consented to by the insurer and authorized by public authorities having jurisdiction over the Project. Such partial occupancy or use may commence whether or not the portion is substantially complete, provided the Owner and Contractor have accepted in writing the responsibilities assigned to each of them for payments, retainage, if any, security, maintenance, heat, utilities, damage to the Work and insurance, and have agreed in writing concerning the period for correction of the Work and commencement of warranties required by the Contract Documents. When the Contractor considers a portion substantially complete, the Contractor shall prepare and submit a list to the Owner as provided under Section 9.7.2. Consent of the Contractor to partial occupancy or use shall not be unreasonably withheld. The stage of the progress of the Work shall be determined by written agreement between the Owner and Contractor.

**§ 9.8.2** Immediately prior to such partial occupancy or use, the Owner and Contractor shall jointly inspect the area to be occupied or portion of the Work to be used in order to determine and record the condition of the Work.

**§ 9.8.3** Unless otherwise agreed upon, partial occupancy or use of a portion or portions of the Work shall not constitute acceptance of Work not complying with the requirements of the Contract Documents.

### **§ 9.9 Final Completion and Final Payment**

**§ 9.9.1** Upon receipt of the Contractor's notice that the Work is ready for final inspection and acceptance and upon receipt of a final Application for Payment, the Owner will promptly make such inspection. When the Owner, to the best of its knowledge and based on its inspection finds the Work acceptable under the Contract Documents and the Contract fully performed, the Owner will promptly make final payment to the Contractor in accordance with and subject to the Contract Documents.

**§ 9.9.2** Neither final payment nor any remaining retained percentage shall become due until the Contractor submits to the Owner (1) an affidavit that payrolls, bills for materials and equipment, and other indebtedness connected with the Work for which the Owner or the Owner's property might be responsible or encumbered (less amounts withheld by Owner) have been paid or otherwise satisfied, (2) a certificate evidencing that insurance required by the Contract Documents to remain in force after final payment is currently in effect and will not be canceled or allowed to expire until at least 30 days' prior written notice has been given to the Owner, (3) a written statement that the Contractor knows of no reason that the insurance will not be renewable to cover the period required by the Contract Documents, (4) consent of surety, if any, to final payment, (5) documentation of any special warranties, such as manufacturers' warranties or specific Subcontractor warranties, and (6) if required by the Owner, other data establishing payment or satisfaction of obligations, such as receipts and releases and waivers of liens, claims, security interests, or encumbrances arising out of the Contract, to the extent and in such form as may be designated by the Owner. If a Subcontractor refuses to furnish a release or waiver required by the Owner, the Contractor may furnish a bond satisfactory to the Owner to indemnify the Owner against such lien, claim, security interest, or encumbrance. If a lien, claim, security interest, or encumbrance remains unsatisfied after payments are made, the Contractor shall refund to the Owner all money that the Owner may be compelled to pay in discharging the lien, claim, security interest, or encumbrance, including all costs and reasonable attorneys' fees.

**§ 9.9.3** If, after Substantial Completion of the Work, final completion thereof is materially delayed through no fault of the Contractor or by issuance of Change Orders affecting final completion, the Owner shall, upon application by the Contractor and approval of such application by the Owner, and without terminating the Contract, make payment of the balance due for that portion of the Work fully completed, corrected, and accepted. If the remaining balance for Work not fully completed or corrected is less than retainage stipulated in the Contract Documents, and if bonds have been furnished, the written consent of the surety to payment of the balance due for that portion of the Work fully completed and accepted shall be submitted by the Contractor to the Owner prior to such payment. Such payment shall be made under terms and conditions governing final payment, except that it shall not constitute a waiver of Claims.

**§ 9.9.4** The making of final payment shall constitute a waiver of Claims by the Owner except those arising from

- .1 liens, Claims, security interests, or encumbrances arising out of the Contract and unsettled;
- .2 failure of the Work to comply with the requirements of the Contract Documents;
- .3 terms of special warranties required by the Contract Documents; or
- .4 audits performed by the Owner, if permitted by the Contract Documents, after final payment.

**§ 9.9.5** Acceptance of final payment by the Contractor, a Subcontractor, or a supplier, shall constitute a waiver of claims by that payee except those previously made in writing and identified by that payee as unsettled at the time of final Application for Payment.

## **ARTICLE 10 PROTECTION OF PERSONS AND PROPERTY**

### **§ 10.1 Safety Precautions and Programs**

The Contractor shall be responsible for initiating, maintaining, and supervising all safety precautions and programs in connection with the performance of the Contract.

### **§ 10.2 Safety of Persons and Property**

**§ 10.2.1** The Contractor shall take reasonable precautions for safety of, and shall provide reasonable protection to prevent damage, injury, or loss to

- .1 employees on the Work and other persons who may be affected thereby;
- .2 the Work and materials and equipment to be incorporated therein, whether in storage on or off the site, under care, custody, or control of the Contractor, a Subcontractor, or a Sub-subcontractor; and
- .3 other property at the site or adjacent thereto, such as trees, shrubs, lawns, walks, pavements, roadways, structures, and utilities not designated for removal, relocation, or replacement in the course of construction.

**§ 10.2.2** The Contractor shall comply with, and give notices required by applicable laws, statutes, ordinances, codes, rules and regulations, and lawful orders of public authorities, bearing on safety of persons or property or their protection from damage, injury, or loss.

**§ 10.2.3** The Contractor shall implement, erect, and maintain, as required by existing conditions and performance of the Contract, reasonable safeguards for safety and protection, including posting danger signs and other warnings against hazards; promulgating safety regulations; and notifying the owners and users of adjacent sites and utilities of the safeguards.

**§ 10.2.4** When use or storage of explosives or other hazardous materials or equipment, or unusual methods are necessary for execution of the Work, the Contractor shall exercise utmost care and carry on such activities under supervision of properly qualified personnel.

**§ 10.2.5** The Contractor shall promptly remedy damage and loss (other than damage or loss insured under property insurance required by the Contract Documents) to property referred to in Sections 10.2.1.2 and 10.2.1.3 caused in whole or in part by the Contractor, a Subcontractor, a Sub-subcontractor, or anyone directly or indirectly employed by any of them, or by anyone for whose acts they may be liable and for which the Contractor is responsible under Sections 10.2.1.2 and 10.2.1.3. The Contractor may make a Claim for the cost to remedy the damage or loss to the extent such damage or loss is attributable to acts or omissions of the Owner or Architect or anyone directly or indirectly employed by either of them, or by anyone for whose acts either of them may be liable, and not attributable to the fault or negligence of the Contractor. The foregoing obligations of the Contractor are in addition to the Contractor's obligations under Section 3.18.

**§ 10.2.6** The Contractor shall designate a responsible member of the Contractor's organization at the site whose duty shall be

the prevention of accidents. This person shall be the Contractor's superintendent unless otherwise designated by the Contractor in writing to the Owner and Architect.

**§ 10.2.7** The Contractor shall not permit any part of the construction or site to be loaded so as to cause damage or create an unsafe condition.

**§ 10.2.8 Injury or Damage to Person or Property**

If either party suffers injury or damage to person or property because of an act or omission of the other party, or of others for whose acts such party is legally responsible, notice of the injury or damage, whether or not insured, shall be given to the other party within a reasonable time not exceeding 21 days after discovery. The notice shall provide sufficient detail to enable the other party to investigate the matter.

**§ 10.3 Hazardous Materials and Substances**

**§ 10.3.1** The Contractor is responsible for compliance with any requirements included in the Contract Documents regarding hazardous materials or substances. If the Contractor encounters a hazardous material or substance not addressed in the Contract Documents and if reasonable precautions will be inadequate to prevent foreseeable bodily injury or death to persons resulting from a material or substance, including but not limited to asbestos or polychlorinated biphenyl (PCB), encountered on the site by the Contractor, the Contractor shall, upon recognizing the condition, immediately stop Work in the affected area and notify the Owner and Architect of the condition.

**§ 10.3.2** Upon receipt of the Contractor's notice, the Owner shall obtain the services of a licensed laboratory to verify the presence or absence of the material or substance reported by the Contractor and, in the event such material or substance is found to be present, to cause it to be rendered harmless. Unless otherwise required by the Contract Documents, the Owner shall furnish in writing to the Contractor and Architect the names and qualifications of persons or entities who are to perform tests verifying the presence or absence of the material or substance or who are to perform the task of removal or safe containment of the material or substance. The Contractor and the Architect will promptly reply to the Owner in writing stating whether or not either has reasonable objection to the persons or entities proposed by the Owner. If either the Contractor or Architect has an objection to a person or entity proposed by the Owner, the Owner shall propose another to whom the Contractor and the Architect have no reasonable objection. When the material or substance has been rendered harmless, Work in the affected area shall resume upon written agreement of the Owner and Contractor. By Change Order, the Contract Time shall be extended appropriately and the Contract Sum shall be increased by the amount of the Contractor's reasonable additional costs of shutdown, delay, and start-up.

**§ 10.3.3** To the fullest extent permitted by law, the Owner shall indemnify and hold harmless the Contractor, Subcontractors, Architect, Architect's consultants, and agents and employees of any of them from and against claims, damages, losses, and expenses, including but not limited to attorneys' fees, arising out of or resulting from performance of the Work in the affected area if in fact the material or substance presents the risk of bodily injury or death as described in Section 10.3.1 and has not been rendered harmless, provided that such claim, damage, loss, or expense is attributable to bodily injury, sickness, disease or death, or to injury to or destruction of tangible property (other than the Work itself), except to the extent that such damage, loss, or expense is due to the fault or negligence of the party seeking indemnity.

**§ 10.3.4** The Owner shall not be responsible under this Section 10.3 for hazardous materials or substances the Contractor brings to the site unless such materials or substances are required by the Contract Documents. The Owner shall be responsible for hazardous materials or substances required by the Contract Documents, except to the extent of the Contractor's fault or negligence in the use and handling of such materials or substances.

**§ 10.3.5** The Contractor shall reimburse the Owner for the cost and expense the Owner incurs (1) for remediation of hazardous materials or substances the Contractor brings to the site and negligently handles, or (2) where the Contractor fails to perform its obligations under Section 10.3.1, except to the extent that the cost and expense are due to the Owner's fault or negligence.

**§ 10.3.6** If, without negligence on the part of the Contractor, the Contractor is held liable by a government agency for the cost of remediation of a hazardous material or substance solely by reason of performing Work as required by the Contract Documents, the Owner shall reimburse the Contractor for all cost and expense thereby incurred.

## § 10.4 Emergencies

In an emergency affecting safety of persons or property, the Contractor shall act, at the Contractor's discretion, to prevent threatened damage, injury, or loss. Additional compensation or extension of time claimed by the Contractor on account of an emergency shall be determined as provided in Article 15 and Article 7.

## ARTICLE 11 INSURANCE AND BONDS

### § 11.1 Contractor's Insurance and Bonds

§ 11.1.1 The Contractor shall purchase and maintain insurance of the types and limits of liability, containing the endorsements, and subject to the terms and conditions, as described in the Agreement or elsewhere in the Contract Documents. The Contractor shall purchase and maintain the required insurance from an insurance company or insurance companies lawfully authorized to issue insurance in the jurisdiction where the Project is located. The Owner, Architect, and Architect's consultants shall be named as additional insureds under the Contractor's commercial general liability policy or as otherwise described in the Contract Documents.

§ 11.1.2 The Contractor shall provide surety bonds of the types, for such penal sums, and subject to such terms and conditions as required by the Contract Documents. The Contractor shall purchase and maintain the required bonds from a company or companies lawfully authorized to issue surety bonds in the jurisdiction where the Project is located.

§ 11.1.3 Upon the request of any person or entity appearing to be a potential beneficiary of bonds covering payment of obligations arising under the Contract, the Contractor shall promptly furnish a copy of the bonds or shall authorize a copy to be furnished.

§ 11.1.4 **Notice of Cancellation or Expiration of Contractor's Required Insurance.** Within three (3) business days of the date the Contractor becomes aware of an impending or actual cancellation or expiration of any insurance required by the Contract Documents, the Contractor shall provide notice to the Owner of such impending or actual cancellation or expiration. Upon receipt of notice from the Contractor, the Owner shall, unless the lapse in coverage arises from an act or omission of the Owner, have the right to stop the Work until the lapse in coverage has been cured by the procurement of replacement coverage by the Contractor. The furnishing of notice by the Contractor shall not relieve the Contractor of any contractual obligation to provide any required coverage.

### § 11.2 Owner's Insurance

§ 11.2.1 The Owner shall purchase and maintain insurance of the types and limits of liability, containing the endorsements, and subject to the terms and conditions, as described in the Agreement or elsewhere in the Contract Documents. The Owner shall purchase and maintain the required insurance from an insurance company or insurance companies lawfully authorized to issue insurance in the jurisdiction where the Project is located.

§ 11.2.2 **Failure to Purchase Required Property Insurance.** If the Owner fails to purchase and maintain the required property insurance, with all of the coverages and in the amounts described in the Agreement or elsewhere in the Contract Documents, the Owner shall inform the Contractor in writing prior to commencement of the Work. Upon receipt of notice from the Owner, the Contractor may delay commencement of the Work and may obtain insurance that will protect the interests of the Contractor, Subcontractors, and Sub-Subcontractors in the Work. When the failure to provide coverage has been cured or resolved, the Contract Sum and Contract Time shall be equitably adjusted. In the event the Owner fails to procure coverage, the Owner waives all rights against the Contractor, Subcontractors, and Sub-subcontractors to the extent the loss to the Owner would have been covered by the insurance to have been procured by the Owner. The cost of the insurance shall be charged to the Owner by a Change Order. If the Owner does not provide written notice, and the Contractor is damaged by the failure or neglect of the Owner to purchase or maintain the required insurance, the Owner shall reimburse the Contractor for all reasonable costs and damages attributable thereto.

§ 11.2.3 **Notice of Cancellation or Expiration of Owner's Required Property Insurance.** Within three (3) business days of the date the Owner becomes aware of an impending or actual cancellation or expiration of any property insurance required by the Contract Documents, the Owner shall provide notice to the Contractor of such impending or actual cancellation or expiration. Unless the lapse in coverage arises from an act or omission of the Contractor: (1) the Contractor, upon receipt of notice from the Owner, shall have the right to stop the Work until the lapse in coverage has been cured by the procurement of replacement coverage by either the Owner or the Contractor; (2) the Contract Time and Contract Sum shall be equitably adjusted; and (3) the Owner waives all rights against the Contractor, Subcontractors, and Sub-subcontractors to the extent any loss to the Owner would have been covered by the insurance had it not expired or been cancelled. If the Contractor purchases replacement

coverage, the cost of the insurance shall be charged to the Owner by an appropriate Change Order. The furnishing of notice by the Owner shall not relieve the Owner of any contractual obligation to provide required insurance.

### **§ 11.3 Waivers of Subrogation**

**§ 11.3.1** The Owner and Contractor waive all rights against (1) each other and any of their subcontractors, sub-subcontractors, agents, and employees, each of the other; (2) the Architect and Architect's consultants; and (3) Separate Contractors, if any, and any of their subcontractors, sub-subcontractors, agents, and employees, for damages caused by fire, or other causes of loss, to the extent those losses are covered by property insurance required by the Agreement or other property insurance applicable to the Project, except such rights as they have to proceeds of such insurance. The Owner or Contractor, as appropriate, shall require similar written waivers in favor of the individuals and entities identified above from the Architect, Architect's consultants, Separate Contractors, subcontractors, and sub-subcontractors. The policies of insurance purchased and maintained by each person or entity agreeing to waive claims pursuant to this section 11.3.1 shall not prohibit this waiver of subrogation. This waiver of subrogation shall be effective as to a person or entity (1) even though that person or entity would otherwise have a duty of indemnification, contractual or otherwise, (2) even though that person or entity did not pay the insurance premium directly or indirectly, or (3) whether or not the person or entity had an insurable interest in the damaged property.

**§ 11.3.2** If during the Project construction period the Owner insures properties, real or personal or both, at or adjacent to the site by property insurance under policies separate from those insuring the Project, or if after final payment property insurance is to be provided on the completed Project through a policy or policies other than those insuring the Project during the construction period, to the extent permissible by such policies, the Owner waives all rights in accordance with the terms of Section 11.3.1 for damages caused by fire or other causes of loss covered by this separate property insurance.

### **§ 11.4 Loss of Use, Business Interruption, and Delay in Completion Insurance**

The Owner, at the Owner's option, may purchase and maintain insurance that will protect the Owner against loss of use of the Owner's property, or the inability to conduct normal operations, due to fire or other causes of loss. The Owner waives all rights of action against the Contractor and Architect for loss of use of the Owner's property, due to fire or other hazards however caused.

### **§ 11.5 Adjustment and Settlement of Insured Loss**

**§ 11.5.1** A loss insured under the property insurance required by the Agreement shall be adjusted by the Owner as fiduciary and made payable to the Owner as fiduciary for the insureds, as their interests may appear, subject to requirements of any applicable mortgagee clause and of Section 11.5.2. The Owner shall pay the Architect and Contractor their just shares of insurance proceeds received by the Owner, and by appropriate agreements the Architect and Contractor shall make payments to their consultants and Subcontractors in similar manner.

**§ 11.5.2** Prior to settlement of an insured loss, the Owner shall notify the Contractor of the terms of the proposed settlement as well as the proposed allocation of the insurance proceeds. The Contractor shall have 14 days from receipt of notice to object to the proposed settlement or allocation of the proceeds. If the Contractor does not object, the Owner shall settle the loss and the Contractor shall be bound by the settlement and allocation. Upon receipt, the Owner shall deposit the insurance proceeds in a separate account and make the appropriate distributions. Thereafter, if no other agreement is made or the Owner does not terminate the Contract for convenience, the Owner and Contractor shall execute a Change Order for reconstruction of the damaged or destroyed Work in the amount allocated for that purpose. If the Contractor timely objects to either the terms of the proposed settlement or the allocation of the proceeds, the Owner may proceed to settle the insured loss, and any dispute between the Owner and Contractor arising out of the settlement or allocation of the proceeds shall be resolved pursuant to Article 15. Pending resolution of any dispute, the Owner may issue a Construction Change Directive for the reconstruction of the damaged or destroyed Work.

## **ARTICLE 12 UNCOVERING AND CORRECTION OF WORK**

### **§ 12.1 Uncovering of Work**

**§ 12.1.1** If a portion of the Work is covered contrary to the Architect's request or to requirements specifically expressed in the Contract Documents, it must, if requested in writing by the Architect, be uncovered for the Architect's examination and be replaced at the Contractor's expense without change in the Contract Time.

**§ 12.1.2** If a portion of the Work has been covered that the Architect has not specifically requested to examine prior to its being covered, the Architect may request to see such Work and it shall be uncovered by the Contractor. If such Work is in

accordance with the Contract Documents, the Contractor shall be entitled to an equitable adjustment to the Contract Sum and Contract Time as may be appropriate. If such Work is not in accordance with the Contract Documents, the costs of uncovering the Work, and the cost of correction, shall be at the Contractor's expense.

## **§ 12.2 Correction of Work**

### **§ 12.2.1 Before Substantial Completion**

The Contractor shall promptly correct Work rejected by the Architect or failing to conform to the requirements of the Contract Documents, discovered before Substantial Completion and whether or not fabricated, installed or completed. Costs of correcting such rejected Work, including additional testing and inspections, the cost of uncovering and replacement, and compensation for the Architect's services and expenses made necessary thereby, shall be at the Contractor's expense.

### **§ 12.2.2 After Substantial Completion**

**§ 12.2.2.1** In addition to the Contractor's obligations under Section 3.5, if, within one year after the date of Substantial Completion of the Work or designated portion thereof or after the date for commencement of warranties established under Section 9.9.1, or by terms of any applicable special warranty required by the Contract Documents, any of the Work is found to be not in accordance with the requirements of the Contract Documents, the Contractor shall correct it promptly after receipt of notice from the Owner to do so, unless the Owner has previously given the Contractor a written acceptance of such condition. The Owner shall give such notice promptly after discovery of the condition. During the one-year period for correction of Work, if the Owner fails to notify the Contractor and give the Contractor an opportunity to make the correction, the Owner waives the rights to require correction by the Contractor and to make a claim for breach of warranty. If the Contractor fails to correct nonconforming Work within a reasonable time during that period after receipt of notice from the Owner or Architect, the Owner may correct it in accordance with Section 2.5.

**§ 12.2.2.2** The one-year period for correction of Work shall be extended with respect to portions of Work first performed after Substantial Completion by the period of time between Substantial Completion and the actual completion of that portion of the Work.

**§ 12.2.2.3** The one-year period for correction of Work shall not be extended by corrective Work performed by the Contractor pursuant to this Section 12.2.

**§ 12.2.3** The Contractor shall remove from the site portions of the Work that are not in accordance with the requirements of the Contract Documents and are neither corrected by the Contractor nor accepted by the Owner.

**§ 12.2.4** The Contractor shall bear the cost of correcting destroyed or damaged construction of the Owner or Separate Contractors, whether completed or partially completed, caused by the Contractor's correction or removal of Work that is not in accordance with the requirements of the Contract Documents.

**§ 12.2.5** Nothing contained in this Section 12.2 shall be construed to establish a period of limitation with respect to other obligations the Contractor has under the Contract Documents. Establishment of the one-year period for correction of Work as described in Section 12.2.2 relates only to the specific obligation of the Contractor to correct the Work, and has no relationship to the time within which the obligation to comply with the Contract Documents may be sought to be enforced, nor to the time within which proceedings may be commenced to establish the Contractor's liability with respect to the Contractor's obligations other than specifically to correct the Work.

## **§ 12.3 Acceptance of Nonconforming Work**

If the Owner prefers to accept Work that is not in accordance with the requirements of the Contract Documents, the Owner may do so instead of requiring its removal and correction, in which case the Contract Sum will be reduced as appropriate and equitable. Such adjustment shall be effected whether or not final payment has been made.

## **ARTICLE 13 MISCELLANEOUS PROVISIONS**

### **§ 13.1 Governing Law**

The Contract shall be governed by the law of the place where the Project is located, excluding that jurisdiction's choice of law rules. If the parties have selected arbitration as the method of binding dispute resolution, the Federal Arbitration Act shall govern Section 15.4.

## **§ 13.2 Successors and Assigns**

**§ 13.2.1** The Owner and Contractor respectively bind themselves, their partners, successors, assigns, and legal representatives to covenants, agreements, and obligations contained in the Contract Documents. Except as provided in Section 13.2.2, neither party to the Contract shall assign the Contract as a whole without written consent of the other. If either party attempts to make an assignment without such consent, that party shall nevertheless remain legally responsible for all obligations under the Contract.

**§ 13.2.2** The Owner may, without consent of the Contractor, assign the Contract to a lender providing construction financing for the Project, if the lender assumes the Owner's rights and obligations under the Contract Documents. The Contractor shall execute all consents reasonably required to facilitate the assignment.

## **§ 13.3 Rights and Remedies**

**§ 13.3.1** Duties and obligations imposed by the Contract Documents and rights and remedies available thereunder shall be in addition to and not a limitation of duties, obligations, rights, and remedies otherwise imposed or available by law.

**§ 13.3.2** No action or failure to act by the Owner, Architect, or Contractor shall constitute a waiver of a right or duty afforded them under the Contract, nor shall such action or failure to act constitute approval of or acquiescence in a breach thereunder, except as may be specifically agreed upon in writing.

## **§ 13.4 Tests and Inspections**

**§ 13.4.1** Tests, inspections, and approvals of portions of the Work shall be made as required by the Contract Documents and by applicable laws, statutes, ordinances, codes, rules, and regulations or lawful orders of public authorities. Unless otherwise provided, the Contractor shall make arrangements for such tests, inspections, and approvals with an independent testing laboratory or entity acceptable to the Owner, or with the appropriate public authority, and shall bear all related costs of tests, inspections, and approvals. The Contractor shall give the Architect timely notice of when and where tests and inspections are to be made so that the Architect may be present for such procedures. The Owner shall bear costs of tests, inspections, or approvals that do not become requirements until after bids are received or negotiations concluded. The Owner shall directly arrange and pay for tests, inspections, or approvals where building codes or applicable laws or regulations so require.

**§ 13.4.2** If the Architect, Owner, or public authorities having jurisdiction determine that portions of the Work require additional testing, inspection, or approval not included under Section 13.4.1, the Architect will, upon written authorization from the Owner, instruct the Contractor to make arrangements for such additional testing, inspection, or approval, by an entity acceptable to the Owner, and the Contractor shall give timely notice to the Architect of when and where tests and inspections are to be made so that the Architect may be present for such procedures. Such costs, except as provided in Section 13.4.3, shall be at the Owner's expense.

**§ 13.4.3** If procedures for testing, inspection, or approval under Sections 13.4.1 and 13.4.2 reveal failure of the portions of the Work to comply with requirements established by the Contract Documents, all costs made necessary by such failure, including those of repeated procedures and compensation for the Architect's services and expenses, shall be at the Contractor's expense.

**§ 13.4.4** Required certificates of testing, inspection, or approval shall, unless otherwise required by the Contract Documents, be secured by the Contractor and promptly delivered to the Architect.

**§ 13.4.5** If the Architect is to observe tests, inspections, or approvals required by the Contract Documents, the Architect will do so promptly and, where practicable, at the normal place of testing.

**§ 13.4.6** Tests or inspections conducted pursuant to the Contract Documents shall be made promptly to avoid unreasonable delay in the Work.

## **§ 13.5 Interest**

Payments due and unpaid under the Contract Documents shall bear interest from the date payment is due at the rate the parties agree upon in writing or, in the absence thereof, at the legal rate prevailing from time to time at the place where the Project is located.

## **ARTICLE 14 TERMINATION OR SUSPENSION OF THE CONTRACT**

### **§ 14.1 Termination by the Contractor**

**§ 14.1.1** The Contractor may terminate the Contract if the Work is stopped for a period of 30 consecutive days through no act or fault of the Contractor, a Subcontractor, a Sub-subcontractor, their agents or employees, or any other persons or entities performing portions of the Work, for any of the following reasons:

- .1 Issuance of an order of a court or other public authority having jurisdiction that requires all Work to be stopped;
- .2 An act of government, such as a declaration of national emergency, that requires all Work to be stopped;
- .3 Because the Architect has not issued a Certificate for Payment and has not notified the Contractor of the reason for withholding certification as provided in Section 9.4.1, or because the Owner has not made payment on a Certificate for Payment within the time stated in the Contract Documents; or
- .4 The Owner has failed to furnish to the Contractor reasonable evidence as required by Section 2.2.

**§ 14.1.2** The Contractor may terminate the Contract if, through no act or fault of the Contractor, a Subcontractor, a Sub-subcontractor, their agents or employees, or any other persons or entities performing portions of the Work, repeated suspensions, delays, or interruptions of the entire Work by the Owner as described in Section 14.3, constitute in the aggregate more than 100 percent of the total number of days scheduled for completion, or 120 days in any 365-day period, whichever is less.

**§ 14.1.3** If one of the reasons described in Section 14.1.1 or 14.1.2 exists, the Contractor may, upon seven days' notice to the Owner and Architect, terminate the Contract and recover from the Owner payment for Work executed, as well as reasonable overhead and profit on Work not executed, and costs incurred by reason of such termination.

**§ 14.1.4** If the Work is stopped for a period of 60 consecutive days through no act or fault of the Contractor, a Subcontractor, a Sub-subcontractor, or their agents or employees or any other persons or entities performing portions of the Work because the Owner has repeatedly failed to fulfill the Owner's obligations under the Contract Documents with respect to matters important to the progress of the Work, the Contractor may, upon seven additional days' notice to the Owner and the Architect, terminate the Contract and recover from the Owner as provided in Section 14.1.3.

### **§ 14.2 Termination by the Owner for Cause**

**§ 14.2.1** The Owner may terminate the Contract if the Contractor

- .1 repeatedly refuses or fails to supply enough properly skilled workers or proper materials;
- .2 fails to make payment to Subcontractors or suppliers in accordance with the respective agreements between the Contractor and the Subcontractors or suppliers;
- .3 repeatedly disregards applicable laws, statutes, ordinances, codes, rules and regulations, or lawful orders of a public authority; or
- .4 otherwise is guilty of substantial breach of a provision of the Contract Documents.

**§ 14.2.2** When any of the reasons described in Section 14.2.1 exist, and upon certification by the Architect that sufficient cause exists to justify such action, the Owner may, without prejudice to any other rights or remedies of the Owner and after giving the Contractor and the Contractor's surety, if any, seven days' notice, terminate employment of the Contractor and may, subject to any prior rights of the surety:

- .1 Exclude the Contractor from the site and take possession of all materials, equipment, tools, and construction equipment and machinery thereon owned by the Contractor;
- .2 Accept assignment of subcontracts pursuant to Section 5.4; and
- .3 Finish the Work by whatever reasonable method the Owner may deem expedient. Upon written request of the Contractor, the Owner shall furnish to the Contractor a detailed accounting of the costs incurred by the Owner in finishing the Work.

**§ 14.2.3** When the Owner terminates the Contract for one of the reasons stated in Section 14.2.1, the Contractor shall not be entitled to receive further payment until the Work is finished.

**§ 14.2.4** If the unpaid balance of the Contract Sum exceeds costs of finishing the Work, including compensation for the Architect's services and expenses made necessary thereby, and other damages incurred by the Owner and not expressly waived, such excess shall be paid to the Contractor. If such costs and damages exceed the unpaid balance, the Contractor shall pay the difference to the Owner. The amount to be paid to the Contractor or Owner, as the case may be, shall be certified by

the Initial Decision Maker, upon application, and this obligation for payment shall survive termination of the Contract.

### **§ 14.3 Suspension by the Owner for Convenience**

**§ 14.3.1** The Owner may, without cause, order the Contractor in writing to suspend, delay or interrupt the Work, in whole or in part for such period of time as the Owner may determine.

**§ 14.3.2** The Contract Sum and Contract Time shall be adjusted for increases in the cost and time caused by suspension, delay, or interruption under Section 14.3.1. Adjustment of the Contract Sum shall include profit. No adjustment shall be made to the extent

- .1 that performance is, was, or would have been, so suspended, delayed, or interrupted, by another cause for which the Contractor is responsible; or
- .2 that an equitable adjustment is made or denied under another provision of the Contract.

### **§ 14.4 Termination by the Owner for Convenience**

**§ 14.4.1** The Owner may, at any time, terminate the Contract for the Owner's convenience and without cause.

**§ 14.4.2** Upon receipt of notice from the Owner of such termination for the Owner's convenience, the Contractor shall

- .1 cease operations as directed by the Owner in the notice;
- .2 take actions necessary, or that the Owner may direct, for the protection and preservation of the Work; and
- .3 except for Work directed to be performed prior to the effective date of termination stated in the notice, terminate all existing subcontracts and purchase orders and enter into no further subcontracts and purchase orders.

**§ 14.4.3** In case of such termination for the Owner's convenience, the Owner shall pay the Contractor for Work properly executed; costs incurred by reason of the termination, including costs attributable to termination of Subcontracts; and the termination fee, if any, set forth in the Agreement.

## **ARTICLE 15 CLAIMS AND DISPUTES**

### **§ 15.1 Claims**

#### **§ 15.1.1 Definition**

A Claim is a demand or assertion by one of the parties seeking, as a matter of right, payment of money, a change in the Contract Time, or other relief with respect to the terms of the Contract. The term "Claim" also includes other disputes and matters in question between the Owner and Contractor arising out of or relating to the Contract. The responsibility to substantiate Claims shall rest with the party making the Claim. This Section 15.1.1 does not require the Owner to file a Claim in order to impose liquidated damages in accordance with the Contract Documents.

#### **§ 15.1.2 Time Limits on Claims**

The Owner and Contractor shall commence all Claims and causes of action against the other and arising out of or related to the Contract, whether in contract, tort, breach of warranty or otherwise, in accordance with the requirements of the binding dispute resolution method selected in the Agreement and within the period specified by applicable law, but in any case not more than 10 years after the date of Substantial Completion of the Work. The Owner and Contractor waive all Claims and causes of action not commenced in accordance with this Section 15.1.2.

#### **§ 15.1.3 Notice of Claims**

**§ 15.1.3.1** Claims by either the Owner or Contractor, where the condition giving rise to the Claim is first discovered prior to expiration of the period for correction of the Work set forth in Section 12.2.2, shall be initiated by notice to the other party and to the Initial Decision Maker with a copy sent to the Architect, if the Architect is not serving as the Initial Decision Maker. Claims by either party under this Section 15.1.3.1 shall be initiated within 21 days after occurrence of the event giving rise to such Claim or within 21 days after the claimant first recognizes the condition giving rise to the Claim, whichever is later.

**§ 15.1.3.2** Claims by either the Owner or Contractor, where the condition giving rise to the Claim is first discovered after expiration of the period for correction of the Work set forth in Section 12.2.2, shall be initiated by notice to the other party. In such event, no decision by the Initial Decision Maker is required.

#### **§ 15.1.4 Continuing Contract Performance**

**§ 15.1.4.1** Pending final resolution of a Claim, except as otherwise agreed in writing or as provided in Section 9.7 and Article 14, the Contractor shall proceed diligently with performance of the Contract and the Owner shall continue to make payments in accordance with the Contract Documents.

**§ 15.1.4.2** The Contract Sum and Contract Time shall be adjusted in accordance with the Initial Decision Maker's decision, subject to the right of either party to proceed in accordance with this Article 15. The Architect will issue Certificates for Payment in accordance with the decision of the Initial Decision Maker.

#### **§ 15.1.5 Claims for Additional Cost**

If the Contractor wishes to make a Claim for an increase in the Contract Sum, notice as provided in Section 15.1.3 shall be given before proceeding to execute the portion of the Work that is the subject of the Claim. Prior notice is not required for Claims relating to an emergency endangering life or property arising under Section 10.4.

#### **§ 15.1.6 Claims for Additional Time**

**§ 15.1.6.1** If the Contractor wishes to make a Claim for an increase in the Contract Time, notice as provided in Section 15.1.3 shall be given. The Contractor's Claim shall include an estimate of cost and of probable effect of delay on progress of the Work. In the case of a continuing delay, only one Claim is necessary.

**§ 15.1.6.2** If adverse weather conditions are the basis for a Claim for additional time, such Claim shall be documented by data substantiating that weather conditions were abnormal for the period of time, could not have been reasonably anticipated, and had an adverse effect on the scheduled construction.

#### **§ 15.1.7 Waiver of Claims for Consequential Damages**

The Contractor and Owner waive Claims against each other for consequential damages arising out of or relating to this Contract. This mutual waiver includes

- .1 damages incurred by the Owner for rental expenses, for losses of use, income, profit, financing, business and reputation, and for loss of management or employee productivity or of the services of such persons; and
- .2 damages incurred by the Contractor for principal office expenses including the compensation of personnel stationed there, for losses of financing, business and reputation, and for loss of profit, except anticipated profit arising directly from the Work.

This mutual waiver is applicable, without limitation, to all consequential damages due to either party's termination in accordance with Article 14. Nothing contained in this Section 15.1.7 shall be deemed to preclude assessment of liquidated damages, when applicable, in accordance with the requirements of the Contract Documents.

#### **§ 15.2 Initial Decision**

**§ 15.2.1** Claims, excluding those where the condition giving rise to the Claim is first discovered after expiration of the period for correction of the Work set forth in Section 12.2.2 or arising under Sections 10.3, 10.4, and 11.5, shall be referred to the Initial Decision Maker for initial decision. The Architect will serve as the Initial Decision Maker, unless otherwise indicated in the Agreement. Except for those Claims excluded by this Section 15.2.1, an initial decision shall be required as a condition precedent to mediation of any Claim. If an initial decision has not been rendered within 30 days after the Claim has been referred to the Initial Decision Maker, the party asserting the Claim may demand mediation and binding dispute resolution without a decision having been rendered. Unless the Initial Decision Maker and all affected parties agree, the Initial Decision Maker will not decide disputes between the Contractor and persons or entities other than the Owner.

**§ 15.2.2** The Initial Decision Maker will review Claims and within ten days of the receipt of a Claim take one or more of the following actions: (1) request additional supporting data from the claimant or a response with supporting data from the other party, (2) reject the Claim in whole or in part, (3) approve the Claim, (4) suggest a compromise, or (5) advise the parties that the Initial Decision Maker is unable to resolve the Claim if the Initial Decision Maker lacks sufficient information to evaluate the merits of the Claim or if the Initial Decision Maker concludes that, in the Initial Decision Maker's sole discretion, it would be inappropriate for the Initial Decision Maker to resolve the Claim.

**§ 15.2.3** In evaluating Claims, the Initial Decision Maker may, but shall not be obligated to, consult with or seek information from either party or from persons with special knowledge or expertise who may assist the Initial Decision Maker in rendering

a decision. The Initial Decision Maker may request the Owner to authorize retention of such persons at the Owner's expense.

**§ 15.2.4** If the Initial Decision Maker requests a party to provide a response to a Claim or to furnish additional supporting data, such party shall respond, within ten days after receipt of the request, and shall either (1) provide a response on the requested supporting data, (2) advise the Initial Decision Maker when the response or supporting data will be furnished, or (3) advise the Initial Decision Maker that no supporting data will be furnished. Upon receipt of the response or supporting data, if any, the Initial Decision Maker will either reject or approve the Claim in whole or in part.

**§ 15.2.5** The Initial Decision Maker will render an initial decision approving or rejecting the Claim, or indicating that the Initial Decision Maker is unable to resolve the Claim. This initial decision shall (1) be in writing; (2) state the reasons therefor; and (3) notify the parties and the Architect, if the Architect is not serving as the Initial Decision Maker, of any change in the Contract Sum or Contract Time or both. The initial decision shall be final and binding on the parties but subject to mediation and, if the parties fail to resolve their dispute through mediation, to binding dispute resolution.

**§ 15.2.6** Either party may file for mediation of an initial decision at any time, subject to the terms of Section 15.2.6.1.

**§ 15.2.6.1** Either party may, within 30 days from the date of receipt of an initial decision, demand in writing that the other party file for mediation. If such a demand is made and the party receiving the demand fails to file for mediation within 30 days after receipt thereof, then both parties waive their rights to mediate or pursue binding dispute resolution proceedings with respect to the initial decision.

**§ 15.2.7** In the event of a Claim against the Contractor, the Owner may, but is not obligated to, notify the surety, if any, of the nature and amount of the Claim. If the Claim relates to a possibility of a Contractor's default, the Owner may, but is not obligated to, notify the surety and request the surety's assistance in resolving the controversy.

**§ 15.2.8** If a Claim relates to or is the subject of a mechanic's lien, the party asserting such Claim may proceed in accordance with applicable law to comply with the lien notice or filing deadlines.

### **§ 15.3 Mediation**

**§ 15.3.1** Claims, disputes, or other matters in controversy arising out of or related to the Contract, except those waived as provided for in Sections 9.10.4, 9.10.5, and 15.1.7, shall be subject to mediation as a condition precedent to binding dispute resolution.

**§ 15.3.2** The parties shall endeavor to resolve their Claims by mediation which, unless the parties mutually agree otherwise, shall be administered by the American Arbitration Association in accordance with its Construction Industry Mediation Procedures in effect on the date of the Agreement. A request for mediation shall be made in writing, delivered to the other party to the Contract, and filed with the person or entity administering the mediation. The request may be made concurrently with the filing of binding dispute resolution proceedings but, in such event, mediation shall proceed in advance of binding dispute resolution proceedings, which shall be stayed pending mediation for a period of 60 days from the date of filing, unless stayed for a longer period by agreement of the parties or court order. If an arbitration is stayed pursuant to this Section 15.3.2, the parties may nonetheless proceed to the selection of the arbitrator(s) and agree upon a schedule for later proceedings.

**§ 15.3.3** Either party may, within 30 days from the date that mediation has been concluded without resolution of the dispute or 60 days after mediation has been demanded without resolution of the dispute, demand in writing that the other party file for binding dispute resolution. If such a demand is made and the party receiving the demand fails to file for binding dispute resolution within 60 days after receipt thereof, then both parties waive their rights to binding dispute resolution proceedings with respect to the initial decision.

**§ 15.3.4** The parties shall share the mediator's fee and any filing fees equally. The mediation shall be held in the place where the Project is located, unless another location is mutually agreed upon. Agreements reached in mediation shall be enforceable as settlement agreements in any court having jurisdiction thereof.

### **§ 15.4 Arbitration**

**§ 15.4.1** If the parties have selected arbitration as the method for binding dispute resolution in the Agreement, any Claim subject to, but not resolved by, mediation shall be subject to arbitration which, unless the parties mutually agree otherwise,

shall be administered by the American Arbitration Association in accordance with its Construction Industry Arbitration Rules in effect on the date of the Agreement. The Arbitration shall be conducted in the place where the Project is located, unless another location is mutually agreed upon. A demand for arbitration shall be made in writing, delivered to the other party to the Contract, and filed with the person or entity administering the arbitration. The party filing a notice of demand for arbitration must assert in the demand all Claims then known to that party on which arbitration is permitted to be demanded.

**§ 15.4.1.1** A demand for arbitration shall be made no earlier than concurrently with the filing of a request for mediation, but in no event shall it be made after the date when the institution of legal or equitable proceedings based on the Claim would be barred by the applicable statute of limitations. For statute of limitations purposes, receipt of a written demand for arbitration by the person or entity administering the arbitration shall constitute the institution of legal or equitable proceedings based on the Claim.

**§ 15.4.2** The award rendered by the arbitrator or arbitrators shall be final, and judgment may be entered upon it in accordance with applicable law in any court having jurisdiction thereof.

**§ 15.4.3** The foregoing agreement to arbitrate and other agreements to arbitrate with an additional person or entity duly consented to by parties to the Agreement, shall be specifically enforceable under applicable law in any court having jurisdiction thereof.

#### **§ 15.4.4 Consolidation or Joinder**

**§ 15.4.4.1** Subject to the rules of the American Arbitration Association or other applicable arbitration rules, either party may consolidate an arbitration conducted under this Agreement with any other arbitration to which it is a party provided that (1) the arbitration agreement governing the other arbitration permits consolidation, (2) the arbitrations to be consolidated substantially involve common questions of law or fact, and (3) the arbitrations employ materially similar procedural rules and methods for selecting arbitrator(s).

**§ 15.4.4.2** Subject to the rules of the American Arbitration Association or other applicable arbitration rules, either party may include by joinder persons or entities substantially involved in a common question of law or fact whose presence is required if complete relief is to be accorded in arbitration, provided that the party sought to be joined consents in writing to such joinder. Consent to arbitration involving an additional person or entity shall not constitute consent to arbitration of any claim, dispute or other matter in question not described in the written consent.

**§ 15.4.4.3** The Owner and Contractor grant to any person or entity made a party to an arbitration conducted under this Section 15.4, whether by joinder or consolidation, the same rights of joinder and consolidation as those of the Owner and Contractor under this Agreement.

### **ARTICLE 16 AUDITS AND INSPECTIONS**

**§ 16.1** The records and documents with respect to all matters covered by this Contract shall be subject at all times to inspection, review or audit by the Owner or any other government agency so authorized by law during the performance of this Contract. The Owner shall have the right to periodic audit of the Contractor's financial statement and condition.

- .1 The Contractor shall maintain accounts and records in accordance with State Auditor's procedures, including personnel, property, financial and programmatic records which sufficiently and properly reflect all direct and indirect costs of any nature expended and services performed in the performance of this Contract and other such records as may be deemed necessary by the Owner to ensure proper accounting for all funds contributed by the Owner to the performance of this Contract and compliance with this Contract.
- .2 The Owner shall maintain these records for a period of six (6) years after termination hereof unless permission to destroy them is granted by the office of the archivist in accordance with RCW Chapter 40.14.

### **ARTICLE 17 FEDERAL PROVISIONS**

#### **§ 17.1 Section 3 – Instructions, Requirements and Income Guidelines**

**§ 17.1.1** The work to be performed under this contract is subject to the requirements of Section 3 of the Housing and Urban Development Act of 1968, as amended, 12 U.S.C. 1701u (Section 3) as implemented by HUD under 24 CFR Part 75 (collectively, the "Section 3 Regulations"). The purpose of Section 3 is to ensure that employment and other economic opportunities generated by HUD assistance or HUD- assisted projects covered by Section 3, shall, to the greatest extent feasible, be directed to low- and

very low-income persons, including persons who are recipients of HUD assistance for housing, with preference for both targeted workers living in the service area or neighborhood of the Development and YouthBuild participants.

**§ 17.1.2** The Contractor agrees to comply with HUD's regulations in 24 CFR part 75, which implement Section 3. Contractor certifies that it is under no contractual or other impediment that would prevent it from complying with the part 75 regulations.

**§ 17.1.3** The Contractor agrees to send to each labor organization or representative of workers with which Contractor has a collective bargaining agreement or other understanding, if any, a notice advising the labor organization or workers' representative of Contractor's commitments under this Section 3 clause, and will post copies of the notice in conspicuous places at the work site where both employees and applicants for training and employment positions can see the notice. The notice shall describe the Section 3 preference, shall set forth minimum number and job titles subject to hire, availability of apprenticeship and training positions, the qualifications for each; and the name and location of the person(s) taking applications for each of the positions; and the anticipated date the work shall begin.

**§ 17.1.4** The Contractor agrees to include this Section 3 clause in every subcontract subject to compliance with regulations in 24 CFR part 75, and agrees to take appropriate action, as provided in an applicable provision of the subcontract or in this Section 3 clause, upon a finding that the subcontractor is in violation of the regulations in 24 CFR part 75. Contractor will not subcontract with any subcontractor where Contractor has notice or knowledge that the subcontractor has been found in violation of the regulations in 24 CFR part 75.

**§ 17.1.5** The Contractor certifies that any vacant employment positions, including training positions, filled (1) after Contractor was selected for the Work but before this Contract was executed, and (2) with persons other than those to whom the regulations of 24 CFR part 75 require employment opportunities to be directed, were not filled to circumvent Contractor's obligations under 24 CFR part 75.

**§ 17.1.6** Noncompliance with HUD's regulations in 24 CFR part 75 may result in sanctions, termination of this Contract for cause under Section 14.2.1 above, and debarment or suspension from future HUD assisted contracts.

**§ 17.1.7** Contractor shall submit to the Owner a Section 3 Work Plan, including hiring and subcontracting activities, prior to Contract execution. Contractor will submit to the Owner with each Application for Payment the Section 3 New Hire Status Report and Individual Certification form. Noncompliance, incorrect, or missing documents will result in progress payments being withheld until all issues are resolved to the satisfaction of the Owner.

**§ 17.1.8** The Contractor, all Subcontractors and Lower-Tier Subcontractors shall submit to the Owner Section 3 Individual Certification forms for each of their personnel performing work on the project site either prior to Contract execution or the commencement of Subcontractors' and Lower-Tier Subcontractors' work. The Contractor will submit to the Owner, with each Application for Payment the Section 3 Labor Hour Benchmark Report for the Contract, all Subcontractors and Lower-Tier Subcontractors. Noncompliance, incorrect, or missing documents may result in progress payments being withheld until all issues are resolved to the satisfaction of the Owner.

#### **§ 17.2 Prohibition Against the Use of Lead Based Paint**

The Contractor shall comply with the prohibition against the use of lead-based paint contained in the Lead Based Paint Poisoning Act (42 USC 4821-4846) as implemented by 24 CFR Part 35.

#### **§ 17.3 Federal Health, Safety, and Accident Prevention**

The Contractor shall ensure that no laborer or mechanic shall be required to work in surroundings or under working conditions which are unsanitary, hazardous, or dangerous to his/her health and/or safety as determined under the construction safety and health standards promulgated by the Secretary of Labor by regulation. The Contractor shall comply with the regulations and standards issued by the Secretary of Labor at 29 CFR Parts 1904 and 1926 Failure to comply may result in imposition of sanctions pursuant to the Contract Work Hours and Safety Standards Act (Public Law 9154, 83 Stat. 96), 40 USC 3701 to 3708 et seq.

#### **§ 17.4 Clean Air and Water**

Contractor shall comply with all requirements of the United States Environmental Protection Agency (EPA) 40 CFR Part 15, 42 USC 7401, 33 USC 1251 et seq., the Federal Water Pollution Control Act 33 USC 1281 et seq., and Executive Order 11738.

#### **§ 17.5 Energy Efficiency**

AIA Document A201 – 2017. Copyright © 1911, 1915, 1918, 1925, 1937, 1951, 1958, 1961, 1963, 1966, 1970, 1976, 1987, 1997, 2007 and 2017. All rights reserved. "The American Institute of Architects," "American Institute of Architects," "AIA," the AIA Logo, and "AIA Contract Documents" are trademarks of The American Institute of Architects. This draft was produced at 11:21:27 PST on 02/18/2025 under Subscription No.20240033487 which expires on , is not for resale, is licensed for one-time use only, and may only be used in accordance with the AIA Contract Documents® Terms of Service. To report copyright violations, e-mail docinfo@aiacontracts.com.

**User Notes:**

(640e2aedf442e4498d0967fa)

The Contractor shall comply with all standards and policies relating to energy efficiency which are contained in the energy conservation plan issued in compliance with the Energy Policy and Conservation Act (Pub. L. 94-163) in Washington State and the Federal Energy Policy and Conservation Act (42 USC 6201).

**§ 17.6 Labor Standards; Davis-Bacon, HUD Non-Routine Maintenance and Related Acts, If Applicable**

The Contractor shall comply with all provisions of the Davis-Bacon Act and Related Acts such as the Housing Act of 1937, the National Housing Act, the Housing and Community Development Act of 1974, the National Affordable Housing Act of 1990, Equal Employment Opportunity 41 CFR Part 60 or similar related Acts for Federal Labor Standards for this Contract. The Contractor is responsible for the full compliance of all employers, including the Contractor, Subcontractors, and all the Lower-Tier Subcontractors with the Labor Standards Provisions applicable to this Project.

**§ 17.7 Interest of Member of Congress**

No member of or delegate to the Congress of the United States of America shall be admitted to any share or part of this Contract or to any benefit to arise therefrom, but this provision shall not be construed to extend to this Contract if made with a corporation for its general benefit. Copeland Anti-Kickback Act 40 USC 3145.

**§ 17.8 Interest of Members, Officers, Commissioners and Employees, or Former Members, Officers and Employees**

No member, officer, or employee of King County Housing Authority, no member of the Governing body of the locality in which the project is situated, no member of the governing body in which the Owner was activated, and no other public official or such who exercises any functions or responsibilities with respect to the project, shall, during his or her tenure, or for one year thereafter, have any interest, direct or indirect, in this Contract or the proceeds thereof.

**§ 17.9 Organization Conflicts of Interest**

- .1 The Contractor warrants that to the best of its knowledge and belief and except as otherwise disclosed, it does not have any organizational conflict of interest which is defined as a situation in which the nature of the work under this Contract and the Contractor's organizational, financial, contractual or other interests are such as:
  - (a.) Award of the Contract may result in an unfair competitive advantage; or
  - (b.) The Contractor's objectivity in performing the Contract Work may be impaired.
- .2 The Contractor agrees that if after award they discover an organizational conflict of interest with respect to this Contract, they shall make an immediate and full disclosure in writing to the Owner, which shall include a description of the action, which the Contractor has taken or intend to take to eliminate or neutralize the conflict. The Owner may, however, terminate the Contract if it deems the action to be in the best interest of the Owner.
- .3 In the event the Contractor was aware of an organizational conflict of interest before the award of this Contract and intentionally did not disclose the conflict to the Owner, the Owner may terminate the Contract for cause under Section 14.2.1 above.
- .4 In the event the Contractor was aware of the organizational conflict of interest before the award of this Contract and intentionally did not disclose the conflict to the Contracting Officer, the Owner may terminate the Contract for default.

**§ 17.10 Lobbying**

Contractor shall be in compliance with the Byrd Anti-Lobbying Amendment 31 USC 3145.

This Agreement entered into as of the day and year first written above.

**KING COUNTY HOUSING AUTHORITY**

**CONTRACTOR'S COMPANY NAME**

\_\_\_\_\_  
SIGNATURE (Owner)

\_\_\_\_\_  
SIGNATURE (Contractor)

\_\_\_\_\_  
NAME (Please Print)

\_\_\_\_\_  
NAME (Please Print)

\_\_\_\_\_  
TITLE (Please Print)

\_\_\_\_\_  
TITLE (Please Print)

\_\_\_\_\_  
DATE

\_\_\_\_\_  
DATE

Contractor's License No.: «»

**CERTIFICATE AS TO CORPORATE PRINCIPAL****CERTIFICATE AS TO CORPORATE PRINCIPAL**

I, \_\_\_\_\_ certify that I am the  
President / Vice President / Secretary / \_\_\_\_\_ of the Entity: Corporation  
/LLC / \_\_\_\_\_, named as the Principal in the foregoing bond. The authorized  
Official of the named bonding agent who signed the said bond on behalf of the Principal, hereby certifies  
that said bond was fully signed, sealed and attested for and in behalf of said Entity by authority of its  
Governing body.

Named Bonding Agent: \_\_\_\_\_

\_\_\_\_\_  
Affix Corporate Seal / Authorized Signature:

## PERFORMANCE AND PAYMENT BOND INSTRUCTIONS

### DIRECTIONS FOR PREPARATION OF PERFORMANCE AND PAYMENT BOND

1. Individual sureties, partnerships, or corporations not in the surety business will not be acceptable.
2. The name of the Principal shall be shown exactly as it appears in the Contract.
3. The penal sum shall not be less than required by the Specifications.
4. If the Principals are partners or joint venturers, each member shall execute the bond as an individual and state its place of residence.
5. If the principal is a corporation, the bond shall be executed under its corporate seal. If the corporation has no corporate seal, it shall so state and affix a scroll or adhesive seal following the corporate name.
6. The official character and authority of the person(s) executing the bond for the Principal, if a corporation, shall be certified by the Secretary or Assistant Secretary thereof under the corporate seal, or copies attached to such records of the corporation as will evidence the official character and authority of the officer signing, duly certified by the Secretary or Assistant Secretary, under the corporate seal, to be true copies.
7. The current power-of-attorney of the person signing for the surety company must be attached to the bond.
8. The date of the bond must not be prior to the date of the Contract.
9. The following information must be placed on the bond by the surety company:
  - a. The Rate of premium in dollars per thousand; and
  - b. The total dollar amount of premium charged
10. The signature of a witness shall appear in the appropriate place attending to the signature of each party of the bond.
11. Type or print the name underneath each signature appearing on the bond
12. An executed copy of the bond must be attached to each copy of the Contract (original counterpart) intended for signing.

**PERFORMANCE AND PAYMENT BOND**

KNOW ALL MEN BY THESE PRESENT, That we the Undersigned, \_\_\_\_\_

as **PRINCIPAL**, and \_\_\_\_\_ as **SURETY** are held and bound unto the **KING COUNTY HOUSING AUTHORITY** of Seattle, Washington, hereinafter called the Public Housing Authority in the penal sum of:

\$ \_\_\_\_\_ and No/100 ( \$ \_\_\_\_\_ ) **DOLLARS**, lawful money of the United States, for the payment of which Lawful money of the United States, for the payment of which sum will and truly be made, we bind ourselves, our heirs, executors, administrators, successors and assigns, jointly and severally, firmly by these presents.

**WHEREAS** the Principal has entered into a certain Contract with the Public Housing Authority dated \_\_\_\_\_, 20\_\_\_\_, a copy of which is hereto attached and made a part hereof.

**NOW, THEREFORE**, the condition of this obligation is such that if the Principal shall in all respects fully perform the Contract and all duly authorized modifications thereof, during its original term and any extensions thereof that may be granted and during any guaranty period for which the Contract provides, and if the Principal shall fully satisfy all claims arising out of the prosecution of the Work under the contract and shall fully indemnify the Public Housing Authority for all expenses which it may incur by reason of such claims, including its attorney’s fees and court costs, and if the Principal shall make full payment to all persons supplying labor, services, materials, or equipment in the prosecution of the Work under the contract, in default of which such persons shall have a direct right of action hereupon, and if the Principal shall pay or cause to be paid all sales and use taxes payable as a result of the performance of the Contract as well as payment of gasoline and special motor fuels taxes in the performance of the Contract and all motor vehicle fees required for commercial motor vehicles used in connection with the performance of the Contract, then this obligation shall be void; otherwise, it shall remain in full force and effect. No modification of the Contract or extension of the term thereof, nor any forbearance on the part of the Public Housing Authority, shall in any way release the Principal or the Surety from liability hereunder. Notice to the Surety of any such modification, extension, or forbearance is hereby waived.

**IN WITNESS WHEREOF**, the aforesaid Principal and Surety have executed this instrument and affixed their seals hereto, this \_\_\_\_\_ day of \_\_\_\_\_ 20\_\_\_\_.

<b>WITNESS:</b>	_____	<b>(Individual Principal)</b>	
	_____	<b>(Business Address)</b>	(Seal)
	_____	<b>(Individual Principal)</b>	
	_____	<b>(Business Address)</b>	(Seal)
<b>ATTEST:</b>	_____	<b>(Corporate Principal)</b>	
	_____	<b>(Business Address)</b>	
		<b>(By)</b>	(Corporate Seal)
		<b>(Title)</b>	
<b>ATTEST:</b>	_____	<b>(Surety)</b>	
	_____	<b>(Business Address)</b>	
		<b>(By)</b>	(Corporate Seal)
		<b>(Title)</b>	

The Rate of Premium on this Bond is \$ \_\_\_\_\_ per thousand.  
 The Total Amount of Premium Charges is \$ \_\_\_\_\_  
**(The above is to be filled in by Surety Company. \* Power of Attorney of person signing for Surety Company must be attached.)**

**KING COUNTY HOUSING AUTHORITY INSURANCE REQUIREMENTS****INSTRUCTIONS / ENDORSEMENT INFORMATION FOR  
COMPLETING, EXECUTING, AND SUBMITTING EVIDENCE OF INSURANCE****A. INSURED CONTRACTOR:**

1. In order to reduce problems and time delays in providing evidence of insurance to the King County Housing Authority you are requested to give your insurance agent or broker a copy of *the Insurance Requirements Sheet along with the Instructions/Endorsement Form(s) for Completing, Executing, and Submitting Evidence of Insurance.*
2. If the agreement requires Workers' Compensation coverage and you have been authorized by the State to self-insure Workers' Compensation, then a copy of the certificate from the State authorizing self-insurance for Workers' Compensation shall meet the requirements for Workers' Compensation insurance covering activities within the State.
3. All questions relating to insurance should be directed to the department or office responsible for your contract, lease, permit, or other agreement.

**B. INSURANCE AGENT OR BROKER:**

1. The appropriate Endorsement Form shall include:
  - a. King County Housing Authority as Additional Insured
  - b. State that the Contractor's Insurance Is Primary
  - c. State King County Housing Authority's Insurance Is Non-Contributory In Claims Settlement Funding

**PLEASE NOTE:** King County Housing Authority **WILL NOT ACCEPT** Certificates of Insurance Alone.

2. More than one insurance policy may be required to comply with the insurance requirements. Endorsement forms appropriate to your insured's agreement, contract, lease or permit are included. In each instance, King County Housing Authority shall be named as additionally insured on the appropriate endorsement forms.
3. You shall have an authorized representative of the insurance company forward the completed endorsement forms with his/her phone number noted at the bottom of the page, to King County Housing Authority.
4. The name of the Insurance Company underwriting the coverage and its address shall be noted on the endorsement form.
5. The "General description of agreement(s) and/or activity(s) insured" shall include reference to the activity and/or to either the specific King County Housing Authority's:
  - a. Project or Site Name
  - b. Contract Number
  - c. Lease Number
  - d. Permit Number
  - e. Construction Approval Number

6. The Coverage and limits for each type of insurance are specified on the insurance requirements sheet. When coverage is on a scheduled basis, then a separate sheet is to be attached to the endorsement listing such scheduled locations, vehicles, etc. so covered.
7. Endorsements to excess policies will be required when primary insurance is insufficient in complying with King County Housing Authority's requirements.
8. If there is insufficient space on the form to note pertinent information, such as inclusions, exclusions or specific provisions, etc., a separate sheet may be attached.
9. When additional sheets are attached, change the number of pages at the bottom of the form to so indicate.
10. Completed Endorsement(s) including cancellation notices and questions relating to the required insurance are to be directed to:

KING COUNTY HOUSING AUTHORITY  
ATTN: ASSET MANAGEMENT DEPARTMENT  
600 ANDOVER PARK WEST, SUITE C  
TUKWILA, WA 98188

11. Improperly Completed Endorsements will be returned to your insured for correction by an authorized representative of the insurance company.
12. For extensions or renewals on insurance policies which have King County Housing Authority Endorsement Form(s) attached, the Housing Authority will accept a copy of the endorsement to extend the period of coverage as evidence of continued coverage.

C. MINIMUM LIMITS:

1. REFER TO "Insurance Requirements" attached.

**INSURANCE REQUIREMENTS FOR BUILDING TRADE CONTRACTORS** *(with Construction Risks)***The Awarded Contractor shall comply as follows:**

Contractor shall procure and maintain, at their expense, for the duration of the contract insurance against claims for injuries to persons or damages to property, which may arise from or in connection with the performance of the work hereunder by the Contractor, his agents, representatives, employees or subcontractors.

**THE KING COUNTY HOUSING AUTHORITY (AUTHORITY) SHALL BE NAMED AS ADDITIONALLY INSURED ON THE APPROPRIATE ENDORSEMENT FORMS.****MINIMUM SCOPE OF INSURANCE:**

Coverage shall be at least as broad as:

1. Insurance Services Office Commercial General Liability coverage including Products / Completed Operations.
2. Insurance Services Office covering any Owned, Leased, Hired and Non-owned, and Automobile Liability.
3. Workers' Compensation insurance as required by State law and Employers Liability coverage.
4. Builders Risk (Property / Course of Construction insurance covering for all risks of loss for all projects in excess of \$250,000.)
5. Professional Liability / Errors and Omission (when applicable).

**MINIMUM LIMITS OF INSURANCE:**

Contractor shall maintain limits no less than:

1. General Liability: \$1,000,000 per occurrence, \$2,000,000 general aggregate, including \$1,000,000 Products / Completed Operations for bodily injury, personal injury and property damage. If Commercial General Liability Insurance or other form with a general aggregate limit is used, either the general aggregate limit shall apply separately to this project / location or the general aggregate limit shall be twice the required occurrence limit.
2. Automobile Liability: \$1,000,000 per accident for bodily injury / property damage.
3. Employer's Liability / Washington Stop Gap: \$1,000,000 per accident for bodily injury, sickness or disease.
4. Builder Risk (Property) / Course of Construction: Completed value of the project.
5. Professional Liability / Errors and Omissions: \$1,000,000 per claim; \$2,000,000 aggregate (when applicable).

**DEDUCTIBLES AND SELF-INSURED RETENTIONS:**

Any deductibles or self-insured retentions must be declared to and approved by the Authority. At the option of the Authority, either: the insurer shall reduce or eliminate such deductibles or self-insured retentions as respects the Authority, its successors and assigns, director, officers, officials, employees, agents, partners and volunteers; or the Contractor shall provide a financial guarantee satisfactory to the Authority guaranteeing payment of losses and related investigations, claim administration and defense expenses.

**NOTE: If this contract deals with hazardous materials or activities (i.e. lead based paint, asbestos, armed security guards) additional provisions covering those exposures must be included in order to protect the Authority's interests.**

**OTHER INSURANCE PROVISIONS:**

**General Liability and Automobile Liability Policies** are to contain, or be endorsed to contain, the following provisions:

1. The Authority, its successors and assigns, director, officers, officials, employees, agents, partners, and volunteers are to be covered as additional insureds with respect to (i) general liability arising out of work done or operations performed by or on behalf of the contractor, including materials, parts or equipment furnished in respect to such work or operations. **The endorsement(s) effectuating the foregoing additional insured coverage shall be ISO form CG 20 10 11 85, or CG 20 10 10 01 issued concurrently with CG 20 37 10 01, or their equivalent<sup>1</sup>** as long as it provides additional insured coverage, and **not** limited to the minimum acceptable as required herein, for completed operations; (ii) automobile liability arising out of vehicles owned, leased, hired, or borrowed by or on behalf of the Contractor; (iii) any insurance written on a claims made basis, shall have a retroactive date that coincides with, or precedes, the commencement of any work under this contract. Evidence of such coverage shall be maintained for a minimum of six (6) years beyond the expiration of the project and if a Claims Made policy is not renewed or replaced, then evidence of an extended reporting period of six (6) years shall be provided.
2. For any claims related to this project, the Contractor's insurance coverage shall be primary insurance as respects the Authority, its successors and assigns, director, officers, officials, employees, agents, partners and volunteers. Any insurance or self-insurance maintained or expired by the Authority, its officers, officials, employees, or volunteers shall be excess of the Contractor's insurance and shall not contribute with it.
3. The Contractor on behalf of itself and its liability insurance carriers release and waive any claims and subrogation rights against The Authority, its successors and assigns, director, officers, officials, employees, agents, partners, and volunteers. The Contractor agrees that they will cause its insurance carriers to include in its policies such a clause or endorsement. If extra cost shall be charged therefore, the Contractor shall pay the same.
4. Each insurance policy required by this clause shall be endorsed to state that coverage shall not be canceled or materially changed, except after thirty (30) days / (ten (10) days for non-payment of premium) without prior written notice given to the Authority through certified mail, with return receipt requested.
5. Maintenance of the proper insurance for the duration of the contract is a material element of the contract. Material changes in the required coverage or cancellation of the coverage shall constitute a material breach of the contract.

**Builders Risk / Course of Construction Policies** shall contain the following provisions:

1. The Authority and its insurers shall be named as loss payees.
2. The insurer shall waive all rights of subrogation against the Authority, its successors and assigns, director, officers, officials, employees, agents, partners and volunteers.

---

<sup>1</sup> "Equivalent" means that any endorsements provided must have the equivalent coverage of the listed endorsements. NOTE: This may cost the Contract extra money to get this coverage.

**ACCEPTABILITY OF INSURERS:**

Insurance is to be placed with insurers with a current A.M. Best's rating of no less than **A-:VII**. Contractors must provide written verification of their insurer's rating.

**VERIFICATION OF COVERAGE:**

Contractor shall furnish the Authority with **original certificates** and **amendatory endorsements** affecting coverage required by this clause. The endorsements should be on forms provided by the Authority or on other than the Authority's forms, provided those endorsements conform fully to the requirements. All certificates and endorsements are to be received and approved by the Authority before work commences in sufficient time to permit Contractor to remedy any deficiencies. The Authority reserves the right to require complete, certified copies of all required insurance policies, or pertinent parts thereof, including endorsements affecting the coverage required by these specifications at any time.

**SUBCONTRACTORS:**

1. Subcontractor shall include the Contractor as additional insured under their policies. All coverages for subcontractors shall be subject to all of the requirements stated herein.
2. Contractor shall be responsible for the adequacy of required coverages for subcontractors, and compile related certificates of insurance and endorsements evidencing subcontractors' compliance.

**INDEMNIFICATION AND HOLD HARMLESS:**

1. To the fullest extent permitted by law the Contractor hereby agrees to indemnify and hold harmless the KCHA, its successors and assigns, directors, officials, officers and employees, volunteers, partners and agents (all foregoing singly and collectively "Indemnitees"), from and against any and all claims losses, harm, costs, liabilities, damages and expenses including, but not limited to, reasonable attorneys' fees arising or resulting from the performance of the Work, or the acts or omissions of the Contractor its successors and assigns, employees, subcontractors or anyone acting on the Contractor's behalf in connection with this Contract or its performance; **PROVIDED**, however, that the Contractor shall not be required to so indemnify any such Indemnitees against liability for damages caused by or resulting from the sole negligence of Indemnitees; **PROVIDED FURTHER** that if such damages are caused by or result from the concurrent negligence of the Indemnitees and the Contractor or anyone acting on the Contractor's behalf, then the Contractor's indemnity hereunder shall be limited to the extent of the negligence of the Contractor, its successors and assigns, et al.
2. The foregoing indemnity is specifically and expressly intended to constitute waiver of the Contractor's immunity under Washington's Industrial Act, RCW Title 51, and that this waiver has been specifically negotiated and agreed upon by the parties.
3. The Contractor hereby agrees to require all its subcontractors or anyone acting under its direction or control or on its behalf in connection with or incidental to the performance of this Contract to execute an indemnity clause identical to the preceding clause, specifically naming KCHA as Indemnitee, and failure to do so shall constitute a material breach of this Contract by the Contractor.

## SITE SPECIFIC SAFETY PLAN REQUIREMENTS

Following is a list of the elements that are typically addressed in a construction site specific safety plan. A site specific safety plan will be one of the required post-selection documents be submitted by the contractor selected through this bid solicitation.

**NOTE:** In addition to the typical elements of a construction safety plan that addresses the contractor, KCHA requires that if a/the employee(s) of the Contractor or any sub-contractor is asked to put on a mask by either a resident or property manager when they are in a building or resident's unit, the employee(s) will do so; the Contractor should reflect this in their safety plan.

The selected contractor with responsible for obtaining similar plans from all subcontractors and for the supervision and enforcement of safety requirements on the site. The contractor's Site-Specific Safety Plan will be submitted to KCHA before any work can begin. The Plan will need to address the following:

1. An initial job/job-site safety orientation and a schedule of weekly safety meetings that show employees and subcontractors what they need to know to perform their job assignments safely.
2. Details how and when to report on-the-job injuries.
3. Identifies on-site available 1st Aid / CPR trained personnel, readily accessible first-aid on the job site and/or access to the nearest clinic or hospital from the job site.
4. Identifies what to do in an emergency, including how to exit the workplace.
5. Lists the required personal protective equipment (PPE) and describes the proper use and care of the PPE.
6. Details the on-site Haz-Com Program that identifies hazardous materials (Asbestos, Lead) or chemicals including instruction about the safe use and storage.
7. Designates an on-site representative responsible for job-site Safety.
8. Designates who is responsible for performing and recording regular periodic site reviews, and inspections for your employees and subcontractors.
9. Describes programs related to housekeeping and jobsite safety.
10. Outlines the job-site specific fall protection plan.
11. Describes electrical and/or power generation controls on-site.
12. Has provisions for trenching /excavations and/or confined space entry.
13. Has provisions for "masking-up"

## SUB-CONTRACTOR VERIFICATION FORM

It is the responsibility of the General Contractor to obtain and verify the Subcontractor’s Information described below. For compliance, the General Contractor must submit a copy of the Subcontractor Verification form prior to the sub starting work. A copy of the Affidavit of Intent form must accompany the applicable Certified Payroll. Without these forms, the Pay Application maybe withheld.

KCHA will review subcontractors’ qualifications, safety record, and the history of compliance (including subcontractor’s principals working under another company name) with labor and other state and federal laws. Based on this review, KCHA reserves the right at its sole discretion to reject subcontractors and require the selected General Contractor to replace or substitute a subcontractor with one acceptable to KCHA.

Name of Company: \_\_\_\_\_

**Physical Address:** \_\_\_\_\_

Contact Name and Title \_\_\_\_\_

Email Address: \_\_\_\_\_ Phone No.: \_\_\_\_\_

WA State Contractor’s License: \_\_\_\_\_ UBI Number: \_\_\_\_\_

Employment Security Number: \_\_\_\_\_ L&I’s Workers’ Comp. Acct. ID: \_\_\_\_\_

Federal Tax ID Number: \_\_\_\_\_ DUNS Number: \_\_\_\_\_

SUB-CONTRACTOR IS A(N):  Individual  Partnership\*  Corporation\*\* – in state of \_\_\_\_\_

\* If Partnership, provide Full Name(s) and Address(es) of all parties

\_\_\_\_\_  
\_\_\_\_\_  
\_\_\_\_\_

\*\* If your company is “also known as (AKA)” or “doing business as (DBA) list all names

\_\_\_\_\_  
\_\_\_\_\_

SUB-CONTRACTOR’S EXPERIENCE MODIFICATION RATE (EMR): 2023\_\_\_\_; 2024\_\_\_\_; 2025\_\_\_\_;  
(If sub-contractor is self-insured, attached proof of EMR stated, showing complete worksheet calculations).

Sub-Contractor is not presently debarred, suspended, proposed for debarment, declared ineligible, or voluntarily excluded from covered transactions by any federal department or agency:

**NOTE:** The penalty for making false statement in offer is prescribed in 18 U.S.C. 1001.

SUBMITTED ON : \_\_\_\_\_ Day of \_\_\_\_\_, 20\_\_\_\_

\_\_\_\_\_  
Signature of General Contractor

\_\_\_\_\_  
Name of General Contractor (Print)

\_\_\_\_\_  
Title of General Contractor (Print)

\_\_\_\_\_  
Date

# Certification of Payments to Influence Federal Transactions

U.S. Department of Housing and Urban Development  
Office of Public and Indian Housing

CONTRACT DOCUMENTS C.7

Public reporting burden for this information collection is estimated to average 30 minutes. This includes the time for collecting, reviewing, and reporting data. The information requested is required to obtain a benefit. This form is used to ensure federal funds are not used to influence members of Congress. There are no assurances of confidentiality. HUD may not conduct or sponsor, and an applicant is not required to respond to a collection of information unless it displays a currently valid OMB control number.

Applicant Name

---

Program/Activity Receiving Federal Grant Funding

---

The undersigned certifies, to the best of his or her knowledge and belief, that:

(1) No Federal appropriated funds have been paid or will be paid, by or on behalf of the undersigned, to any person for influencing or attempting to influence an officer or employee of an agency, a Member of Congress, an officer or employee of Congress, or an employee of a Member of Congress in connection with the awarding of any Federal contract, the making of any Federal grant, the making of any Federal loan, the entering into of any cooperative agreement, and the extension, continuation, renewal, amendment, or modification of any Federal contract, grant, loan, or cooperative agreement.

(2) If any funds other than Federal appropriated funds have been paid or will be paid to any person for influencing or attempting to influence an officer or employee of an agency, a Member of Congress, an officer or employee of Congress, or an employee of a Member of Congress in connection with this Federal contract, grant, loan, or cooperative agreement, the undersigned shall complete and submit Standard Form-LLL, Disclosure Form to Report Lobbying, in accordance with its instructions.

(3) The undersigned shall require that the language of this certification be included in the award documents for all subawards at all tiers (including subcontracts, subgrants, and contracts under grants, loans, and cooperative agreements) and that all sub recipients shall certify and disclose accordingly.

This certification is a material representation of fact upon which reliance was placed when this transaction was made or entered into. Submission of this certification is a prerequisite for making or entering into this transaction imposed by Section 1352, Title 31, U.S. Code. Any person who fails to file the required certification shall be subject to a civil penalty of not less than \$10,000 and not more than \$100,000 for each such failure.

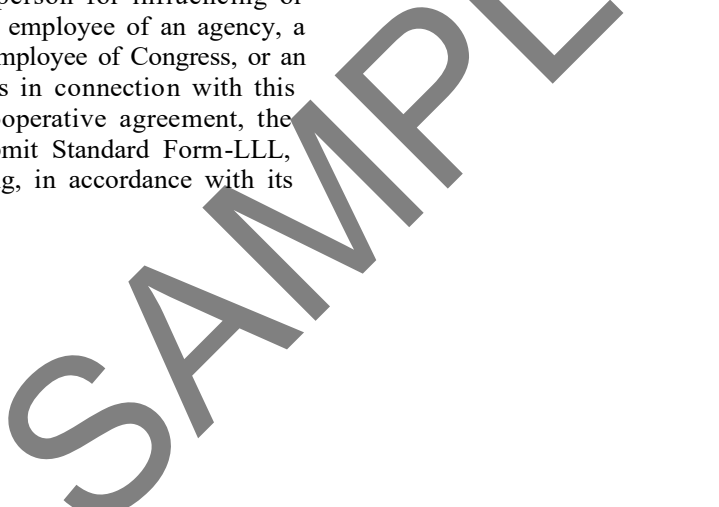

I hereby certify that all the information stated herein, as well as any information provided in the accompaniment herewith, is true and accurate.

**Warning:** HUD will prosecute false claims and statements. Conviction may result in criminal and/or civil penalties. (18 U.S.C. 1001, 1010, 1012; 31 U.S.C. 3729, 3802)

Name of Authorized Official

Title

Signature

Date (mm/dd/yyyy)

## DISCLOSURE OF LOBBYING ACTIVITIES

Complete this form to disclose lobbying activities pursuant to 31 U.S.C.1352

Approved by OMB  
4040-0013

<b>1. * Type of Federal Action:</b> <input checked="" type="checkbox"/> a. contract <input type="checkbox"/> b. grant <input type="checkbox"/> c. cooperative agreement <input type="checkbox"/> d. loan <input type="checkbox"/> e. loan guarantee <input type="checkbox"/> f. loan insurance	<b>2. * Status of Federal Action:</b> <input checked="" type="checkbox"/> a. bid/offer/application <input type="checkbox"/> b. initial award <input type="checkbox"/> c. post-award	<b>3. * Report Type:</b> <input checked="" type="checkbox"/> a. initial filing <input type="checkbox"/> b. material change
--	--	--

**4. Name and Address of Reporting Entity:**

Prime     SubAwardee

\* Name:

\* Street 1:     Street 2:

\* City:     State:     Zip:

Congressional District, if known:

**5. If Reporting Entity in No.4 is Subawardee, Enter Name and Address of Prime:**

<b>6. * Federal Department/Agency:</b> <input style="background-color: yellow;" type="text"/>	<b>7. * Federal Program Name/Description:</b> <input type="text"/> CFDA Number, if applicable: <input type="text"/>
--	---

<b>8. Federal Action Number, if known:</b> <input type="text"/>	<b>9. Award Amount, if known:</b> \$ <input type="text"/>
--	--

**10. a. Name and Address of Lobbying Registrant:**

Prefix  \* First Name  Middle Name

\* Last Name  Suffix

\* Street 1:     Street 2:

\* City:     State:     Zip:

**b. Individual Performing Services** (including address if different from No. 10a)

Prefix  \* First Name  Middle Name

\* Last Name  Suffix

\* Street 1:     Street 2:

\* City:     State:     Zip:

**11.** Information requested through this form is authorized by title 31 U.S.C. section 1352. This disclosure of lobbying activities is a material representation of fact upon which reliance was placed by the tier above when the transaction was made or entered into. This disclosure is required pursuant to 31 U.S.C. 1352. This information will be reported to the Congress semi-annually and will be available for public inspection. Any person who fails to file the required disclosure shall be subject to a civil penalty of not less than \$10,000 and not more than \$100,000 for each such failure.

**\* Signature:**

**\* Name:** Prefix  \* First Name  Middle Name

\* Last Name  Suffix

**Title:**     **Telephone No.:**     **Date:**



**CERTIFICATION OF COMPLIANCE WITH  
WASHINGTON STATE WAGE PAYMENT STATUTES**

The Bidder hereby certifies that, within the three (3) year period immediately preceding the bid solicitation as shown below, that the Bidder is/was not a “willful” violator, as defined in RCW 49.48.082, or any provisions of RCW 49.46 or RCW 49.52, as determined by a final and binding citation and notice of assessment issued by the Washington State Department of Labor & Industries through a civil judgment entered by a court of limited or general jurisdiction.

Solicitation Date: \_\_\_\_\_

**I certify under penalty, of perjury under the laws of the State of Washington that the foregoing is true and correct.**

Company Name – please print

SIGNATURE OF AUTHORIZED OFFICIAL\*

TITLE

PRINTED NAME OF AUTHORIZED OFFICIAL

DATE

CITY

STATE

Check One:

- Individual  Partnership
- Joint Venture  Corporation

State of Incorporation, or if not a corporation, State where business entity was formed:

\_\_\_\_\_

If a co-partnership, give company name under which business is transacted:

\_\_\_\_\_

*\* If a corporation, this Certification must be executed in the corporate name by the president or vice president (or any other corporate office accompanied by evidence of authority to sign). If a co-partnership, Certification must be executed by a partner.*



**SECTION 3 – INDIVIDUAL CERTIFICATION FORM**

Section 3 of the Housing and Urban Development (HUD) Act of 1968, as amended, requires that Housing Authorities and agencies receiving HUD funding, to the greatest extent feasible, provide economic opportunities to low-income persons. **Information provided on this form shall remain confidential and be used for reporting purposes only. *Print all information***

NAME: \_\_\_\_\_

ADDRESS: \_\_\_\_\_

EMAIL ADDRESS: \_\_\_\_\_ PHONE NUMBER: \_\_\_\_\_

HIRE DATE: \_\_\_\_\_ POSITION TITLE: \_\_\_\_\_

EMPLOYER / COMPANY NAME: \_\_\_\_\_

PROJECT NAME: \_\_\_\_\_

1. I am a resident in a KCHA Property. \_\_\_\_\_ Yes \_\_\_\_\_ No

Property Name: \_\_\_\_\_

2. I am currently in KCHA's Section 8 Program. \_\_\_\_\_ Yes \_\_\_\_\_ No

3. I am currently a participant in a HUD YouthBuild Program. \_\_\_\_\_ Yes \_\_\_\_\_ No

4. County and Income Details (*check appropriated boxes*):a. I live in **KITSAP COUNTY** andMy **TOTAL** income for the past 12 months was: (*check appropriate box*)

\_\_\_\_ Below or Equal to \$61,000 \_\_\_\_\_ Greater than \$61,000

b. I live in **KING or SNOHOMISH COUNTY** andMy **TOTAL** income for the past 12 months was: (*check appropriate box*)

\_\_\_\_ Below or Equal to \$70,650 \_\_\_\_\_ Greater than \$70,650

c. I live in **PIERCE COUNTY** andMy **TOTAL** income for the past 12 months was: (*check appropriate box*)

\_\_\_\_ Below or Equal to \$60,200 \_\_\_\_\_ Greater than \$60,200

d. I live in **SKAGIT COUNTY** andMy **TOTAL** income for the past 12 months was: (*check appropriate box*)

\_\_\_\_ Below or Equal to \$51,050 \_\_\_\_\_ Greater than \$51,050

e. I live in **THURSTON COUNTY** andMy **TOTAL** income for the past 12 months was: (*check appropriate box*)

\_\_\_\_ Below or Equal to \$57,400 \_\_\_\_\_ Greater than \$57,400

\_\_\_\_ f. I live in \_\_\_\_\_ COUNTY and  
My **TOTAL** income for the past 12 months was: \$ \_\_\_\_\_

5. In the past five years, I have been a resident of public housing or Section 8 assisted housing managed by KCHA; a resident of other public housing projects or Section 8 assisted housing, or a \_\_\_\_\_ Yes \_\_\_\_\_ No YouthBuild participant.

I hereby certify under the **penalty of perjury** that the information above is true and correct.

\_\_\_\_\_  
Signature

\_\_\_\_\_  
Date

If submitting for a new hire, attach completed forms to Labor Hours Benchmark Status Report and submit to project manager. If submitting for Section 3 business qualification, attach to Section 3 Business Certification Form. For questions, please contact KCHA by email at [section3@kcha.org](mailto:section3@kcha.org).

## SECTION 3 – INDIVIDUAL CERTIFICATION FORM FAQ's

**Question:** What is this form?

**Answer:** This form is a Section 3 Certification Form that will be used to determine if an individual is a Section 3 worker as defined by HUD 24 CFR 75 and the KCHA.

**Question:** Who fills out this form?

**Answer:** Any individual who is paid in full or part with HUD funds. (If unsure if position is HUD funded, please contact Contract administrator.)

**Question:** What will this form be used for?

**Answer:** This form will be used for the purpose of determining Section 3 eligibility and for statistical purposes.

**Question:** Who collects this form and where does it go?

**Answer:** Any employer or contractor that has a contract with the KCHA that is HUD funded will collect this data from any employee who was employed within the last five years. Once the data is collected the original copy will come to KCHA.

**Question:** Who is a KCHA Resident?

**Answer:** Someone who lives in a KCHA Housing Development whose name is listed on a current lease.

**Question:** How long should I go back to calculate my income?

**Answer:** Individuals should calculate back 12 months from their date of hire.

**Question:** What if I don't live in King County?

**Answer:** Individuals who do not reside in King County may still be eligible to be certified by KCHA as a Section 3 resident.

If you have more specific questions, please contact KCHA at [section3@kcha.org](mailto:section3@kcha.org).

## SECTION 3 – LABOR HOURS BENCHMARK REPORT - INSTRUCTIONS

Complete the Labor Hours Benchmark Status Report as indicated below and return the completed form along with the pay application(s) for the same period.

Return the Labor Hours Benchmark Status Report and pay application to:

King County Housing Authority  
600 Andover Park West  
Tukwila, WA 98188

Attn: \_\_\_\_\_

Email: \_\_\_\_\_

### REPORT LINES:

- 1) Name of the project as it appears on the Contract
- 2) Company Name
- 3) Name of the person filling out the Labor Hours Benchmark Status Report
- 4) Phone number of the person filling out the Labor Hours Benchmark Status Report
- 5) Email address of the person filling out the Labor Hours Benchmark Status Report
- 6) Contract number as it appears on the Contract
- 7) Contract Award date (date of Letter of Award)
- 8) Reporting Period – should be the same as the pay application period
- 9) Total hours worked by all workers on the project – this will be everyone that is listed on the certified payrolls during Reporting Period.
- 10) Total hours worked on the project by Section 3 workers during the Reporting Period.

A Section 3 worker is identified as:

- a. The worker's income for the previous or annualized calendar year is below the income limit established by HUD; or
- b. Is employed by a Section 3 business concern; or
- c. Is a YouthBuild participant.

These will be the workers identified as Section 3 employees upon the submittal of their Section 3 Individual Certification Form at the beginning of the project OR when they were brought onto the project. A copy of these forms should be available from your company's payroll office. Copies can also be obtained by submitting a request to [section3@kcha.org](mailto:section3@kcha.org). Please include your company's name, project name and contact information.

- 11) Total hours worked on the project by Targeted Section 3 workers during the Reporting Period.

A Targeted Section 3 worker is identified as:

- a. Employed by a Section 3 business concern; or
- b. Is a resident of public housing or Section 8 assisted housing; or
- c. Resides within one mile of the project site.

These workers will be identified as Targeted Section 3 employees upon the submittal of their Section 3 Individual Certification Form at the beginning of the project OR when they were brought onto the project. A copy of these forms should be available from your company's payroll office. Copies can also be obtained by submitting a request to [section3@kcha.org](mailto:section3@kcha.org). Please include your company's name, project name and contact information.

*See sample scenarios on pgs. 3 & 4*

## SECTION 3 – LABOR HOURS BENCHMARK REPORT

### GENERAL INFORMATION

- 1) PROJECT NAME: \_\_\_\_\_
- 2) COMPANY NAME: \_\_\_\_\_
- 3) CONTACT PERSON: \_\_\_\_\_
- 4) CONTACT PHONE NO.: \_\_\_\_\_
- 5) CONTACT EMAIL ADDRESS: \_\_\_\_\_
- 6) CONTRACT NO.: \_\_\_\_\_                      7) CONTRACT AWARD DATE: \_\_\_\_\_

### SECTION 3 LABOR HOUR BENCHMARKS

- 8) REPORTING PERIOD:    FROM: \_\_\_\_\_                      TO: \_\_\_\_\_

The totals below are for YOUR COMPANY ONLY and JUST THOSE WORKERS WORKING ON THE PROJECT SITE.

- 9) **TOTAL LABOR HOURS FOR ALL WORKERS ON THE PROJECT DURING THE REPORTING PERIOD** *(onsite work crew)*: \_\_\_\_\_
- 10) **TOTAL LABOR HOURS FOR ALL SECTION 3 WORKERS ON THE PROJECT DURING THE REPORTING PERIOD** *(onsite work crew who self-certified as Section 3 Workers)*: \_\_\_\_\_
- 11) **TOTAL LABOR HOURS FOR ALL TARGETED SECTION 3 WORKERS ON THE PROJECT DURING THE REPORTING PERIOD** *(onsite work crew who self-certified as Targeted Section 3 Workers)*: \_\_\_\_\_

I certify that the information in this report is true and correct to the best of my knowledge:

SIGNATURE	TITLE
PRINT NAME	DATE

To be completed by KCHA Staff  
RECEIVED BY:

SIGNATURE	TITLE
PRINT NAME	DATE

SCENARIO 1:

A crew of 5 none of whom self-certified as a Section 3 worker.

Reporting period is from June 1 to June 30, 2022.

The total hours that the crew worked on the project site during the reporting period totaled 1,000.

**SECTION 3 LABOR HOUR BENCHMARKS**

8) REPORTING PERIOD: FROM: 6-1-22 TO: 6-30-22

**The totals below are for YOUR COMPANY ONLY and JUST THOSE WORKERS WORKING ON THE PROJECT SITE.**

9) TOTAL LABOR HOURS FOR ALL WORKERS ON THE PROJECT DURING THE REPORTING PERIOD (*onsite work crew*): 1000

10) TOTAL LABOR HOURS FOR ALL SECTION 3 WORKERS ON THE PROJECT DURING THE REPORTING PERIOD (*onsite work crew who self-certified as Section 3 Workers*): 0

11) TOTAL LABOR HOURS FOR ALL **TARGETED** SECTION 3 WORKERS ON THE PROJECT DURING THE REPORTING PERIOD (*onsite work crew who self-certified as Targeted Section 3 Workers*): 0

SCENARIO 2:

A crew of 5, two of whom self-certified as Section 3 workers.

Reporting period is from June 1 to June 30, 2022.

The total hours that the crew worked on the project site during the reporting period totaled 1,000.

The total hours of the two that self-certified as Section 3 workers during the reporting period totaled 80.

**SECTION 3 LABOR HOUR BENCHMARKS**

8) REPORTING PERIOD: FROM: 6-1-22 TO: 6-30-22

**The totals below are for YOUR COMPANY ONLY and JUST THOSE WORKERS WORKING ON THE PROJECT SITE.**

9) TOTAL LABOR HOURS FOR ALL WORKERS ON THE PROJECT DURING THE REPORTING PERIOD (*onsite work crew*): 1000

10) TOTAL LABOR HOURS FOR ALL SECTION 3 WORKERS ON THE PROJECT DURING THE REPORTING PERIOD (*onsite work crew who self-certified as Section 3 Workers*): 80

11) TOTAL LABOR HOURS FOR ALL **TARGETED** SECTION 3 WORKERS ON THE PROJECT DURING THE REPORTING PERIOD (*onsite work crew who self-certified as Targeted Section 3 Workers*): 0

SCENARIO 3:

A crew of 5, one of whom self-certified as a Section 3 worker and the other as a Targeted Section 3 worker.

Reporting period is from June 1 to June 30.

The total hours that the crew worked on the project site during the reporting period totaled 1,000.

The total hours of the one that self-certified as a Section 3 worker during the reporting period totaled 40.

The total hours of the one that self-certified as a Targeted Section 3 worker during the reporting period totaled 40.

**SECTION 3 LABOR HOUR BENCHMARKS**

---

8) REPORTING PERIOD: FROM: 6-1-22 TO: 6-30-22

**The totals below are for YOUR COMPANY ONLY and JUST THOSE WORKERS WORKING ON THE PROJECT SITE.**

9) **TOTAL LABOR HOURS FOR ALL WORKERS ON THE PROJECT DURING THE REPORTING PERIOD** (*onsite work crew*): 1000

10) **TOTAL LABOR HOURS FOR ALL SECTION 3 WORKERS ON THE PROJECT DURING THE REPORTING PERIOD** (*onsite work crew who self-certified as Section 3 Workers*): 40

11) **TOTAL LABOR HOURS FOR ALL TARGETED SECTION 3 WORKERS ON THE PROJECT DURING THE REPORTING PERIOD** (*onsite work crew who self-certified as Targeted Section 3 Workers*): 40

---

SCENARIO 4:

A crew of 5, (in this scenario, it does not matter if there are Section 3 workers or not)

Reporting period is from June 1 to June 30, 2022.

The total hours that the crew worked on the project during the reporting period totaled ZERO.

**SECTION 3 LABOR HOUR BENCHMARKS**

---

8) REPORTING PERIOD: FROM: 6-1-22 TO: 6-30-22

**The totals below are for YOUR COMPANY ONLY and JUST THOSE WORKERS WORKING ON THE PROJECT SITE.**

9) **TOTAL LABOR HOURS FOR ALL WORKERS ON THE PROJECT DURING THE REPORTING PERIOD** (*onsite work crew*): 0

10) **TOTAL LABOR HOURS FOR ALL SECTION 3 WORKERS ON THE PROJECT DURING THE REPORTING PERIOD** (*onsite work crew who self-certified as Section 3 Workers*): 0

11) **TOTAL LABOR HOURS FOR ALL TARGETED SECTION 3 WORKERS ON THE PROJECT DURING THE REPORTING PERIOD** (*onsite work crew who self-certified as Targeted Section 3 Workers*): 0

---

**YES, A LABOR HOUR BENCH MARK FORM HAS TO BE SUBMITTED EVEN IF NO WORK IS PERFORMED BUT THE GC/SUB (ALL TIERS) HAVE NOT FINISHED THE PROJECT.**

## **D - SECTION**

### **THIRD PARTY REPORTS**

**There are no third party reports for this project.**

## **E - SECTION**

### **DRAWINGS & SPECIFICATIONS**

- E.1            Scope of Work and Technical Specifications**
- E.2            Drawings (if not included – see attached)**

## SCOPE OF WORK & TECHNICAL SPECIFICATIONS

### SCOPE OF WORK

#### DIVISION 1 – GENERAL REQUIREMENTS

01 10 00	Summary
01 26 00	Contract Modification Procedures
01 29 00	Payment Procedures
01 31 00	Project Management & Coordination
01 32 00	Construction Progress Documentation
01 33 00	Submittal Procedures
01 40 00	Quality Requirements
01 50 00	Temporary Facilities & Controls
01 60 00	Product Requirements
01 73 00	Execution
01 73 29	Cutting and Patching
01 74 19	Construction Waste Management
01 77 00	Closeout
01 78 23	Operation and Maintenance Data
01 78 39	Project Record Documents
*****	KCHA Pay Application Form (sample)
*****	KCHA Substitute Request Form (sample)

#### DIVISION 02 – SITE CONSTRUCTION

02 41 19 Selective Demolition

#### DIVISION 05 – METALS (NOT USED)

05 12 00 Structural Steel Framing

05 50 00 Weilding

#### DIVISION 06 – WOOD & PLASTICS (NOT USED)

06 10 00 Rough Carpentry

#### DIVISION 07 – THERMAL MOISTURE CONTROL

07 18 00 Traffic Coatings

07 62 00 Sheet Metal Flashing and Trim

#### DIVISION 09 – FINISHES (NOT USED)

09 90 00 Exterior Paint and Coatings

## LIST OF DRAWINGS

4- plans – Preliminary Bid Set 08/15/2025

# SPECIFICATIONS

**Greenbridge Apt. Buildings A, B & C**

**Contract Number: AW2501531**

**Walkway Repairs**

Page 1 of 30

## SECTION 011000 - SUMMARY

### PART 1 - GENERAL

#### 1.1 WORK COVERED BY CONTRACT DOCUMENTS

- A. Project Identification: Greenbridge – Salmon Creek Structural Repairs to Walkway
1. Project Location: Greenbridge – 9915 7th Ave. S.W., Seattle, WA 98106
- B. The Work consists of, but is not limited to:
1. Structural repairs for the walkways at Greenbridge Apartments in Seattle, WA. The repairs are to be in accordance with WSEBC Chapter 3 provisions for all compliance methods, section 301.2 and Chapter 4 repairs. Work will include selective demolition of walkway components, removal and reinstallation of specified railings, and installation of new structural and non-structural elements of exterior walkway.
  2. Demolition:
    - a. Remove and discard existing wood top rails at stairs.
    - b. Remove soffit and vent strip to allow access to for structural work.
    - c. Remove plywood sheathing as required to allow access for structural work.
    - d. Temporarily remove and store for reinstallation existing guardrail.
    - e. Remove and dispose of existing walkway wood beams, knee braces and columns.
    - f. Remove and dispose of the threshold between stair landing and walkway.
    - g. Remove and replace existing downspouts to match existing.
  3. Metal
    - a. Replace existing knee braces with powder coated HSS6x6x3/16 (ref S3.0 in Plans)
    - b. Replace existing columns with powder coated HSS6x4x3/16 columns (ref S3.0 in Plans)
    - c. Install powder coated HS10x6x3/16 beams (ref S3.0 in Plans)
    - d. Install metal flashing with drip edge on walkway ledge.
    - e. Install threshold at stair landing and walkway seam. Ensure grade is ADA compliant.
    - f. Install saddle flashing at wall corners and at flat wall (ref A3.1 in Plans)
    - g. Install Simpson DTT2Z-SDS2.5 at deck edge (ref S3.0 in Plans)
  4. Wood
    - a. Install new plywood sheathing where existing was removed.
    - b. Install 4" x 4" blocking with panel edge nailing.
    - c. Install new composite wood top rail to match existing.
    - d. Replace decayed beams with new 7" x 11 1/4" PSL Beams (ref S2.0 in Plans).
    - e. Replace decayed beams with new 5 1/4" x 9 1/4" PSL Beams (ref S2.0 in Plans).
    - f. Replace decayed beams with new 7" x 9 1/2" PSL Beams (ref S2.0 in Plans).
    - g. Replace decayed beams with new 7" x 11 7/8" PSL Beams (ref S2.0 in Plans).
    - h. Replace decayed beams with new 7" x 9 1/4" PSL Beams (ref S2.0 in Plans).
  5. Finishes
    - a. Deck Coating – Rhino Extreme, Rhino Lining Auburn 253-735-1960 (ref Addendum #1 Deck Coating on pg. A1.2 in Plans)

## SPECIFICATIONS

Greenbridge Apt. Buildings A, B & C

Contract Number: AW2501531

Walkway Repairs

Page 2 of 30

**1) For bidding purposes, include Rhino Lining Extreme as deck coating instead of Polydeck 150 as noted in bid set drawings.**

- 2) Epoxy primer coat.
- 3) Spray applied waterproof membrane.
- 4) Rhino Extreme approx. 80-10 mill thick
- 5) Base coat with quartz embedded.
- 6) UV Topcoat (color to match existing, contractor to submit color samples to consultant).

b. Paint Sherwin Williams Superpaint with 10-year warranty.

- 1) Zinc rich for metal corrosion – Sherwin Williams Zinc Clad 5
- 2) Sherwin Williams Pro Industrial DTM for installed/existing Metal and steel.

C. Scope of Work.

1. Remove and store for re-installation all existing metal railings at walkway (stair railings to remain installed).
2. Remove soffit and floor sheathing as required to perform structural work. Install new soffit, vent strip and plywood sheathing where removed. Install dryer vents at all dryer vents exhaust.
3. Replace the walkway support posts and knee brace assembly with steel framing at buildings 'A', 'B' and 'C'.
4. Utilize existing knife plates for connecting new HSS knee braces and HSS beams.
5. Replace walkway edge wood beams in-kind at buildings 'A', 'B' and 'C'.
6. Provide temporary support and bracing to structure as required to ensure safe passage of tenants and proper installation of new structural members.
7. Remove and discard existing wood top rail at stair towers and install new composite wood top rail to existing stair guardrail to remain.
8. Remove and replace threshold between stair landing and walkway,
9. Clean existing waterproof membrane and install new drip edge and corner flashings. Install new deck coating over the entire walkway surface.
10. Tape, mud, sand (level 4 finish), prime and paint entire soffit.
11. Remove corrosion, clean and paint with a zinc rich primer and exterior paint to existing stair steel beams, columns, and angles.
12. Remove and replace existing downspouts.
13. Prime and paint exterior wall at upper floor mezzanine

### 1.2 WORK SEQUENCE

A. The Work shall be completed in 120 calendar days from the date of Notice to Proceed.

B. Contractor will submit (2) written schedules outlining dates and duration of job including:

1. General schedule including:
  - a. Construction start date.
  - b. Schedule for work
  - c. Anticipated final completion date.
2. 2-Week Lookahead Schedule
  - a. Updated and distributed weekly.
  - b. Includes specific and detailed information about daily anticipated activities and respective locations to be performed on site.

## SPECIFICATIONS

**Greenbridge Apt. Buildings A, B & C**

**Contract Number: AW2501531**

**Walkway Repairs**

Page 3 of 30

### 1.3 LIQUIDATED DAMAGES

- A. Liquidated damages will be assessed for each calendar day that the Contractor exceeds the time for completion in the amount of \$1,500.

### 1.4 USE OF THE PREMISES

- A. Use of Site: Limit use of premises to work areas. Do not disturb portions of site beyond areas in which the Work is indicated.
  - 1. Owner Occupancy: Allow for resident occupancy of site. Owner will occupy the site and existing building during entire construction period. Cooperate with Owner during construction operations to minimize conflicts and facilitate safe resident usage.
  - 2. Driveways and Entrances: Keep driveways and entrances serving premises clear and available to residents and emergency vehicles at all times. Do not use these areas for parking or storage of materials.
  - 3. Use of Existing Building: Maintain existing building in a weathertight condition throughout construction period. Repair damage caused by construction operations. Protect property, the buildings and occupants during construction period.
  - 4. Locations for staging, dumpsters and sorting will be discussed during pre-bid meeting and confirmed during pre-con meeting.
  - 5. Contractor may be present on-site during work hours (8am-5pm) unless approved by owner.
- B. Tenant access may be restricted for one eight-hour period per location to all walkways to be replaced. Tenant access must be re-established at the end of eight-hour period to allow access to units. All safety measures must be in place at time of re-establishment of access.
- C. Contractor means and methods shall determine how tenants access building during construction which may include construction of a temporary access route.

### 1.5 PERMITS

- A. KCHA is responsible for acquiring the building permit prior to Notice To Proceed. Contractor is responsible for obtaining and paying for all other required permits and for the coordination of all required inspections. Contractor shall be reimbursed the face value of the permit fees plus overhead and profit as indicated in the specifications.

### 1.6 PAYMENT PROCEDURES

- A. Coordinate preparation of the Schedule of Values with preparation of Contractor's Construction Schedule.
- B. Each Application for Payment shall be consistent with previous applications and payments.

## SPECIFICATIONS

**Greenbridge Apt. Buildings A, B & C**

**Contract Number: AW2501531**

**Walkway Repairs**

Page 4 of 30

- C. Entries shall match data on the Schedule of Values and Contractor's Construction Schedule. Use updated schedules if revisions were made.
- D. Waivers of Lien: With each Application for Payment, submit conditional waivers lien from every entity who is lawfully entitled to file a lien arising out of the Contract and related to the Work covered by the payment.
  - 1. Submit partial waivers on each item for amount requested, before deduction for retainage, on each item.
  - 2. When an application shows completion of an item, submit final or full waivers.
  - 3. Owner reserves the right to designate which entities involved in the Work must submit waivers.
    - a. Submit final Application for Payment with or preceded by final waivers from every entity involved with performance of the Work covered by the application who is lawfully entitled to a lien.
- E. Final Payment Application: Submit final Application for Payment with releases and close out supporting documentation.

### 1.7 PROJECT MEETINGS

- A. Preconstruction Conference: Schedule a preconstruction conference before starting construction, at a time convenient to Owner, but no later than seven days after execution of the Agreement.
- B. Progress Meetings: Conduct progress meetings at weekly intervals.

### 1.8 SUBMITTALS

- A. Subcontract list. Prepare written information that demonstrates capabilities and experience of firm or persons within 10 days of bid acceptance.
- B. Follow Washington Industrial Safety and Health Act (WISHA) regional directives and provide a site-specific safety program that will require an accident prevention and hazard analysis plan for the contractor and each subcontractor on the work site. The Contractor shall submit a site-specific Accident Prevention Program (APP) to the Owner's representative prior to the initial scheduled construction meeting.
- C. Submittal package showing all materials to be used on-site. Included in material submittal will be manufacturer's installation instructions, SDS, specifications and shop drawings as required. Submittals to be approved by architect prior to installation.
  - 1. Material Submittal shall be in standard industry format with transmittal page indicating material description, product identification number, reference to drawing's detail or specification section, title of document provided in submittal and list of attached shop drawings or substitution request.

### 1.9 TEMPORARY FACILITIES

## SPECIFICATIONS

**Greenbridge Apt. Buildings A, B & C**

**Contract Number: AW2501531**

**Walkway Repairs**

Page 5 of 30

- A. Sanitary Facilities: Provide temporary toilets, and wash facilities. Comply with regulations and health codes for type, number, location, operation, and maintenance of fixtures and facilities.
- B. Use of Owner's existing electric power service will be permitted where available.
- C. Parking spaces and an additional laydown area shall be available to the contractor for storage containers and parking. Do not park in marked tenant spaces without 48 hr. notice to management.

### 1.10 EXECUTION REQUIREMENTS

- A. General: Maintain constant access and use of egress throughout construction. Contractor to determine means and methods for maintaining use and access to egress throughout project. Pathways to remain clear of debris and tools so that tenants can enter or exit as needed safely. Clean Project site and work areas daily, including common areas. Coordinate progress cleaning for joint-use areas where more than one installer has worked. Enforce requirements strictly. Dispose of materials lawfully.

### 1.11 CUTTING AND PATCHING

#### A. Quality Assurance

- 1. Structural Elements: Do not cut and patch structural elements in a manner that could change their load-carrying capacity or load-deflection ratio.
- 2. Visual Requirements: Do not cut and patch construction in a manner that results in visual evidence of cutting and patching. Do not cut and patch construction exposed on the exterior or in occupied spaces in a manner that would, in Owner's opinion, reduce the building's aesthetic qualities. Remove and replace construction that has been cut and patched in a visually unsatisfactory manner.

#### B. Performance

- 1. Cutting: Cut existing construction by sawing, drilling, breaking, chipping, grinding, and similar operations, using methods least likely to damage elements retained or adjoining construction. If possible, review proposed procedures with original Installer; comply with original Installer's written recommendations.
- 2. Patching: Patch construction by filling, repairing, refinishing, closing up, and similar operations following performance of other Work. Patch with durable seams that are as invisible as possible. Provide materials and comply with installation requirements specified in other Sections of these Specifications.
  - a. Exposed Finishes: Restore exposed finishes of patched areas and extend finish restoration into retained adjoining construction in a manner that will eliminate evidence of patching and refinishing.
  - b. Exterior Building Enclosure: Patch components in a manner that restores enclosure to a weathertight condition.

### 1.12 CLOSEOUT PROCEDURES

## SPECIFICATIONS

**Greenbridge Apt. Buildings A, B & C**

**Contract Number: AW2501531**

**Walkway Repairs**

Page 6 of 30

- A. General: Provide final cleaning. Conduct cleaning and waste-removal operations to comply with local laws and ordinances and Federal and local environmental and antipollution regulations.
  - 1. Prior to acceptance of the work at each building, clean project site, yard, and grounds, in areas disturbed by construction activities, including landscape development areas, of rubbish, waste material, litter, and other foreign substances.
- B. Prior to final acceptance and final payment
  - 1. Submit a written warranty covering labor and materials for a period of two (2) years from final completion.

PART 2 - PRODUCTS (not used)

PART 3 - EXECUTION (not used)

**END OF SECTION 01100**

# SPECIFICATIONS

**Greenbridge Apt. Buildings A, B & C**

**Contract Number: AW2501531**

**Walkway Repairs**

Page 7 of 30

## SECTION 017419 - CONSTRUCTION WASTE MANAGEMENT

### PART 1 - GENERAL

#### 1.1 SUMMARY

- A. Section includes Administrative and procedural requirements for construction waste management activities.
- B. All materials removed are to be legally disposed of offsite.

#### 1.2 QUALITY ASSURANCE

- A. Regulatory Requirements: Conduct construction waste management activities in accordance with State of Washington RCW 39.04.13, and all other applicable laws and ordinances.

### PART 2 - PRODUCTS (Not Used)

### PART 3 - EXECUTION

#### 3.1 REMOVAL OF CONSTRUCTION WASTE MATERIALS

- A. Remove CDL waste materials from project site on a regular basis. Do not allow CDL waste to accumulate on-site.
- B. Transport CDL waste materials off Owner's property and legally dispose of them.
- C. Burning of CDL waste is not permitted.

END OF SECTION 017419

# SPECIFICATIONS

**Greenbridge Apt. Buildings A, B & C**

**Contract Number: AW2501531**

**Walkway Repairs**

Page 8 of 30

## SECTION 024119 - SELECTIVE DEMOLITION

### PART 1 - GENERAL

#### 1.1 SUMMARY

- A. This Section includes demolition, and removal and replacement.

#### 1.2 MATERIALS OWNERSHIP

- A. Except for items or materials indicated to be reused, salvaged, reinstalled, or otherwise indicated to remain Owner's property, demolished materials shall become Contractor's property and shall be removed from Project site.

#### 1.3 PROJECT CONDITIONS

- A. Owner will occupy portions of building immediately adjacent to selective demolition area. Conduct selective demolition so Owner's operations will not be disrupted. Provide not less than 72-hours' notice to Owner of activities that will affect Owner's operations.
- B. Maintain access to existing walkways, corridors, and other adjacent occupied or used facilities.
  - 1. Do not close or obstruct walkways, corridors, or other occupied or used facilities without written permission from owner and authorities having jurisdiction.
- C. Owner assumes no responsibility for condition of areas to be selectively demolished.
  - 1. Conditions existing at time of inspection for bidding purpose will be maintained by Owner as far as practical.
- D. Hazardous Materials: It is not expected that hazardous materials will be encountered in the Work.
  - 1. Comply with all applicable laws regarding removal and disposal of hazardous materials.
  - 2. If materials suspected of containing hazardous materials are encountered, do not disturb and immediately notify Owner.
- E. Utility Service: Maintain existing utilities indicated to remain in service and protect them against damage during selective demolition operations.

### PART 2 - PRODUCTS

#### 2.1 REPAIR MATERIALS

- A. Use repair materials identical to existing materials or as indicated.
  - 1. If identical materials are unavailable or cannot be used for exposed surfaces, use materials that visually match existing adjacent surfaces to the fullest extent possible.
  - 2. Use materials whose installed performance equals or surpasses that of existing materials.

## SPECIFICATIONS

**Greenbridge Apt. Buildings A, B & C**

**Contract Number: AW2501531**

**Walkway Repairs**

Page 9 of 30

### PART 3 - EXECUTION

#### 3.1 EXAMINATION

- A. Survey existing conditions and correlate with requirements indicated to determine extent of selective demolition required.

#### 3.2 PREPARATION

- A. Site Access and Temporary Controls: Conduct selective demolition and debris-removal operations to ensure minimum interference with roads, streets, walks, walkways, and other adjacent occupied and used facilities.
  - 1. Do not close or obstruct streets, walks, walkways, or other adjacent occupied or used facilities without permission from Owner and authorities having jurisdiction. Provide alternate routes around closed or obstructed traffic ways if required by governing regulations.
  - 2. Erect temporary protection, such as walks, fences, railings, canopies, and covered passageways, where required by authorities having jurisdiction.
  - 3. Protect existing site improvements, appurtenances, and landscaping to remain.

#### 3.3 SELECTIVE DEMOLITION

- A. General: Demolish and remove existing construction only to the extent required by new construction and as indicated. Use methods required to complete the Work within limitations of governing regulations.

END OF SECTION 024119

# SPECIFICATIONS

**Greenbridge Apt. Buildings A, B & C**

**Contract Number: AW2501531**

**Walkway Repairs**

Page 10 of 30

## **SECTION 051200 - STRUCTURAL STEEL FRAMING**

### **PART 1 GENERAL**

#### **1.01 SECTION INCLUDES**

- A. Structural steel framing members.
- B. Structural steel support members.
- C. Base plates.

#### **1.02 RELATED REQUIREMENTS**

- A. Section 05 05 60 - Welding.
- B. Section 05 50 00 - Metal Fabrications: Steel fabrications affecting structural steel work.
- C. Section 09 91 13 - Exterior Painting: Paint finish.

#### **1.03 REFERENCE STANDARDS**

- A. AISC 303 - Code of Standard Practice for Steel Buildings and Bridges; 2016.
- B. AISC 325 - Steel Construction Manual; 2017.
- C. AISC 341 - Seismic Provisions for Structural Steel Buildings; 2022.
- D. AISC 360 - Specification for Structural Steel Buildings; 2022.
- E. ASTM A6/A6M - Standard Specification for General Requirements for Rolled Structural Steel Bars, Plates, Shapes, and Sheet Piling; 2023.
- F. ASTM A36/A36M - Standard Specification for Carbon Structural Steel; 2019.
- G. ASTM A53/A53M - Standard Specification for Pipe, Steel, Black and Hot-Dipped, Zinc-Coated, Welded and Seamless; 2012.
- H. ASTM A108 - Standard Specification for Steel Bar, Carbon and Alloy, Cold-Finished; 2018.
- I. ASTM A123/A123M - Standard Specification for Zinc (Hot-Dip Galvanized) Coatings on Iron and Steel Products; 2017.
- J. ASTM A153/A153M - Standard Specification for Zinc Coating (Hot-Dip) on Iron and Steel Hardware; 2016a.
- K. ASTM A959 - Standard Guide for Specifying Harmonized Standard Grade Compositions for Wrought Stainless Steels; 2019.

## SPECIFICATIONS

**Greenbridge Apt. Buildings A, B & C**

**Contract Number: AW2501531**

**Walkway Repairs**

Page 11 of 30

- L. ASTM A992/A992M - Standard Specification for Structural Steel Shapes; 2020.
  - M. ASTM F436/F436M - Standard Specification for Hardened Steel Washers Inch and Metric Dimensions; 2019.
  - N. ASTM F1554 - Standard Specification for Anchor Bolts, Steel, 36, 55, and 105-ksi Yield Strength; 2020.
  - O. AWS B2.1/B2.1M - Specification for Welding Procedure and Performance Qualification; 2014 (Amended 2015).
  - P. AWS D1.1/D1.1M - Structural Welding Code - Steel; 2020, with Errata (2021).
- NFPA 51B - Standard for Fire Prevention during Welding, Cutting, and Other Hot Work; 2019.

### 1.04 SUBMITTALS

- A. Product Data: Submit manufacturer's product data and installation instructions for each material and product used.
- B. Shop Drawings: Indicate profiles, sizes, materials, finishes, numbers of each item, connection attachments, reinforcing, anchorage, size and type of fasteners, and accessories. Include drawings, elevations, and details where applicable.
  - 1. Prepare placing plan locating structural connectors.
  - 2. Include embedded items, including anchor bolts.
  - 3. Indicate welded connections using standard AWS A2.4 welding symbols. Indicate net weld lengths.
- C. Certificate: Submit qualification letter showing that the fabricator, erector, and welders are qualified and attesting that completed work is in accordance with this specification.

### 1.05 QUALITY ASSURANCE

- A. Comply with governing codes and regulations. Provide products of acceptable manufacturers which have been in satisfactory use in similar service for three years. Use experienced installers. Deliver, handle, and store materials in accordance with manufacturer's instructions.
- B. Standards: AISC 303, Code of Standard Practice for Steel Buildings and Bridges, and applicable regulations.
- C. Fabricator Qualifications:
  - 1. Company specializing in performing the work of this section with minimum (5) years of documented experience with commercial quality of work of comparable scope.
  - 2. Certified by AISC Quality Certification Program: Stand for Steel Building Structures (STD).

## SPECIFICATIONS

**Greenbridge Apt. Buildings A, B & C**

**Contract Number: AW2501531**

**Walkway Repairs**

Page 12 of 30

Web site: [www.aisc.org](http://www.aisc.org)

Non-AISC Certified steel fabricators shall have minimum (5) years' experience on similar projects of equal or larger complexity and scope.

D. Erector Qualifications:

1. Company specializing in performing the work of this section with minimum (5) years of documented experience with commercial quality of work of comparable scope.
2. Certified by AISC Quality Certification Program:
  - a. Certified Steel Erector (CSE).

E. Welders: AWS Certified, and Washington Association of Building Officials (WABO) Standard Qualification Procedure, in conformance to Section 05 05 60.

F. Testing: Independent testing laboratory to perform Special Inspections as indicated in the Structural General Notes.

G. Erection Tolerances: AISC standards

### 1.06 DELIVERY, STORAGE, AND HANDLING

- A. Storage: Store metal above ground on platforms or skids above snow or mud. Locate items to permit easy access for inspection and identification. Do not store on structure in a manner causing distortion or damage to structure.
- B. Protect from moisture and corrosion until erected.
- C. Include templates and instructions for proper setting of anchor bolts.

### · PART 2 PRODUCTS

#### 2.01 MATERIALS

- A. Structural Steel: As specified in the Structural drawings.
- B. Auxiliary Materials:
  1. Direct Tension Indicators: ASTM A959
  2. Electrodes for Welding: AWS Code.

#### 2.02 FABRICATION

- A. Fabricate structural steel in accordance with requirements of the referenced AISC Specifications and details as shown on accepted shop drawings.
  1. Identify steel at mill showing grade and yield point.
  2. Identify each piece with erection mark corresponding to identification noted on erection drawings.

## SPECIFICATIONS

**Greenbridge Apt. Buildings A, B & C**

**Contract Number: AW2501531**

**Walkway Repairs**

Page 13 of 30

- B. Shop fabricated to greatest extent possible.
- C. Cutting: Do no flame cutting by hand, except as accepted in writing by the Structural Engineer, and in strict conformance to NFPA 51B. Where approved, smooth hand cuts by chipping, planing, or grinding. Cut and fit to required tolerances. No sharp kinks or bends permitted.
- D. Straightened Material: Examine straightened material prior to fabrication for signs of distress or other defects. No distressed or otherwise defective material accepted.
- E. Continuously seal joined members by continuous welds. Grind exposed welds smooth.
- F. Connections: Punch and drill steel for attachment of other materials shown or attached permanently to structural steel. Provide required connection angles, plates, and brackets. Attach as shown on drawings. Weld or bolt shop connections as indicated.
- G. Base and Bearing Plates: Drill and fabricate to accurate sizes as drawn. Include fasteners and accessories required for installation.
  - 1. Manufacturer of bearing material to perform bonding.
  - 2. Protect bearing surfaces from damage. Bearing pads with scratches, or other marks, will be rejected.
- H. Where finishing is required, complete assembly, including welding of units, before start of finishing operations. Finish surfaces of members exposed in final structure free of markings, burrs, and other defects.

### 2.03 FABRICATION TOLERANCES

- A. Unless otherwise noted, fabricate structural members to AISC Specifications for allowable tolerances.
- B. Straightness: Conform to ASTM A6/A6M tolerances allowed by wide flanged shapes for tolerances of structural members of single rolled shapes or built-up structural members.

### 2.04 FINISH

- A. Prepare structural component surfaces in accordance with SSPC-SP 1.
- B. Shop Painting:
  - 1. Shop paint metal fabrications, except members or portions of members to be embedded in concrete or masonry, unless otherwise specified.
  - 2. Remove scale, rust and other deleterious materials before applying shop coat.
  - 3. Immediately after surface preparation, brush or spray on primer in accordance with manufacturer's instructions and at a rate to provide uniform dry film thickness of 2.5 to 3.5 mils dry for each coat. Use painting methods that will result in full coverage of joints, corners, edges and exposed surfaces.

## SPECIFICATIONS

**Greenbridge Apt. Buildings A, B & C**

**Contract Number: AW2501531**

**Walkway Repairs**

Page 14 of 30

- C. Galvanize structural steel members (where indicated) to comply with ASTM A123/A123M. Provide minimum 1.7 oz. /sq. ft. galvanized coating.

### · PART 3 EXECUTION

#### **3.01 EXAMINATION**

- A. Verify that conditions are appropriate for erection of structural steel and that the work may properly proceed.

#### **3.02 INSTALLATION**

- A. Comply with AISC codes and specifications, and with AWS D1.1/D1.1M Structural Welding Code.
- B. Employ a registered Engineer to check elevations and plumb and level tolerances. Certify that installed work is within AISC Standards. Owner will engage a Testing and Special Inspection Agency to inspect welded and bolted connections according to the conditions indicated in the Statement of Special Inspections in the Structural General Notes.
- C. Where exposed to view, grind welds smooth and flush, to match and blend with adjoining surfaces.

**END OF SECTION**

# SPECIFICATIONS

**Greenbridge Apt. Buildings A, B & C**

**Contract Number: AW2501531**

**Walkway Repairs**

Page 15 of 30

## SECTION 055000 - METAL FABRICATIONS

### PART 1 GENERAL

#### 1.01 SECTION INCLUDES

- A. Shop fabricated steel items, including:
  - 1. Steel shapes, plates, bars, tubes, pipes, and items that are not part of the structural steel or other metal systems specified elsewhere.

#### 1.02 RELATED REQUIREMENTS

- A. Section 05 05 23 - Welding.
- B. Section 09 91 13 - Exterior Painting: Paint finish.

#### 1.03 REFERENCE STANDARDS

- A. AISC 303 - Code of Standard Practice for Steel Buildings and Bridges; 2016.
- B. AISC 325 - Steel Construction Manual; 2017.
- C. AISC 341 - Seismic Provisions for Structural Steel Buildings; 2022.
- D. AISC 360 - Specification for Structural Steel Buildings; 2022.
- E. ASTM A36/A36M - Standard Specification for Carbon Structural Steel; 2019.
- F. ASTM A53/A53M - Standard Specification for Pipe, Steel, Black and Hot-Dipped, Zinc-Coated, Welded and Seamless; 2012.
- G. ASTM A123/A123M - Standard Specification for Zinc (Hot-Dip Galvanized) Coatings on Iron and Steel Products; 2017.
- H. ASTM A283/A283M - Standard Specification for Low and Intermediate Tensile Strength Carbon Steel Plates; 2018.
- I. ASTM A500/A500M - Standard Specification for Cold-Formed Welded and Seamless Carbon Steel Structural Tubing in Rounds and Shapes; 2013.
- J. ASTM A780/A780M - Standard Practice for Repair of Damaged and Uncoated Areas of Hot-Dip Galvanized Coatings; 2020.
- K. AWS A2.4 - Standard Symbols for Welding, Brazing, and Nondestructive Examination; 2012.
- L. AWS D1.1/D1.1M - Structural Welding Code - Steel; 2020, with Errata (2021).
- M. NAAMM AMP 500-06 - Metal Finishes Manual; 2006.

## SPECIFICATIONS

**Greenbridge Apt. Buildings A, B & C**

**Contract Number: AW2501531**

**Walkway Repairs**

Page 16 of 30

- N. NAAMM AMP 555-92 - Code of Standard Practice for the Architectural Metal Industry (Including Miscellaneous Iron); 1992.

### 1.04 SUBMITTALS

- A. See Section 01 33 00 - Administrative Requirements, for submittal procedures.
- B. Shop Drawings: Indicate profiles, sizes, materials, finishes, numbers of each item, connection attachments, reinforcing, anchorage, size and type of fasteners, and accessories. Include erection drawings, elevations, and details where applicable.
1. Prepare placing plan locating structural connectors.
  2. Include embedded items, including anchor bolts.
  3. Indicate welded connections using standard AWS A2.4 welding symbols. Indicate net weld lengths.
- C. Product Data: Submit manufacturer's publications, specifications, anchor details and installation instructions for products to be used in the fabrication of metal fabrications, including shop paint primer products and grout.
- D. Welders' Certificates: Submit certification for welders employed on the project, verifying AWS and WABO qualification / certification as described in Quality Assurance below.
- E. Samples:
1. Provide mock-up at Owner's request. Mock-up may be incorporated into work.

### 1.05 QUALITY ASSURANCE

- A. Fabricator Qualifications: Company specializing in work of this sections with minimum 5 years documented experience.
- B. Welder Qualifications / Certifications: Each welder performing work on this project shall be qualified before commencement of welding on this project, in accordance with the American Welding Society (AWS) and Washington Association of Building Officials (WABO).
- C. Take field measurements prior to preparation of shop drawings and fabrication, where possible. Do not delay job progress; allow for trimming and fitting wherever taking field measurements before fabrication might delay work.
- D. Furnish inserts and anchoring devices that must be set in concrete for installation of metal fabrications. Coordinate delivery with other work to avoid delays.
- E. Shop Assembly: Pre-assemble items in shop to greatest extent possible to minimize field splicing and assembly. Disassemble units only as necessary for shipping and handling limitations. Clearly mark units for reassembly and coordinated installation.

## · PART 2 PRODUCTS

### 2.01 MATERIALS - STEEL

## SPECIFICATIONS

**Greenbridge Apt. Buildings A, B & C**

**Contract Number: AW2501531**

**Walkway Repairs**

Page 17 of 30

- A. Metal Surfaces - General: For fabrication of metal work which will be exposed to view, use only materials which are smooth and free of surface blemishes including pitting, seam marks, roller marks, rolled trade names and roughness.
- B. Steel Sections: ASTM A36/A36M.
- C. Steel Tubing: ASTM A500/A500M Grade B cold-formed structural tubing.
- D. Plates: ASTM A36/A36M.
- E. Pipe: ASTM A53/A53M Grade B Schedule 40, hot-dip galvanized finish.
- F. Welding Electrodes: Conform to AWS standards in accordance with Section 05 05 60.
  
- G. Shop and Touch-Up Primer: per Sections 09 91 13 and 09 91 23, complying with VOC limitations of authorities having jurisdiction.
- H. Touch-Up Primer for Galvanized Surfaces: Product complying with ASTM A780/A780M, for application 2.5 mil dry thickness.
- I. Fasteners: Provide zinc plated (ASTM A123) fasteners for exterior use or where built into exterior walls. Select fasteners of the type, grade and class required. Bolts shall be machine bolts meeting ASTM A307 or as noted on plans.
  - 1. Provide stainless steel fasteners when called for in drawings or specifications.
  - 2. Provide neoprene or other acceptable material for separation of dissimilar metals.
- J. Grout: Non-shrink grout per Structural General Notes.

### 2.02 FABRICATION

- A. Fit and shop assemble items in largest practical sections, for delivery to site.
- B. Fabricate items with joints tightly fitted and secured.
- C. Use materials of size and thickness shown or, if not shown, of required size and thickness to produce strength and durability in finished product. Work to dimensions shown or accepted on shop drawings, using proven details of fabrication and support. Use type of materials shown or specified for various components of work.
- D. Form exposed work true to line and level with accurate angles and surfaces and straight sharp edges. Ease exposed edges to a radius of approximately 1/32 inch unless otherwise specifically shown. Form bent metal corners to smallest radius possible without causing grain separation or otherwise impairing work.
- E. Form exposed connection with hairline joints, flush and smooth, using concealed fasteners wherever possible. Use exposed fasteners of type shown or, if not shown, socket type flat-head (countersunk) screws or bolts. Provide sufficient backing at screw locations to cover at least three threads.
- F. Provide for anchorage of type suitable for use with supporting structure. Fabricate and space anchoring devices as shown and as required to provide adequate support for intended use. See Architectural and Structural drawings.

## SPECIFICATIONS

**Greenbridge Apt. Buildings A, B & C**

**Contract Number: AW2501531**

**Walkway Repairs**

Page 18 of 30

- G. Cut, reinforce, drill and tap metal fabrications as required to receive finish hardware and similar items. Provide holes and connections for work of other trades.
- H. Weld corners and seams continuously, complying with AWS recommendations. Grind exposed welds smooth and flush, to match and blend with adjoining surfaces.
- I. Grind exposed joints flush and smooth with adjacent finish surface. Make exposed joints butt tight, flush, and hairline. Ease exposed edges to small uniform radius.
- J. Supply components required for anchorage of fabrications. Fabricate anchors and related components of same material and finish as fabrication, except where specifically noted otherwise. See Structural drawings.

### 2.03 FABRICATED ITEMS

#### A. Miscellaneous Non-Structural Steel Items:

- 1. Provide miscellaneous steel framing and supports that are not a part of structural steel framework, as required to complete work, including pipe downspouts, support brackets, scuppers, column caps, bent plate fascia members, etc.
- 2. Fabricate miscellaneous units to sizes, shapes, and profiles shown or, if not shown, of required dimensions to receive adjacent other work to be retained by framing.
- 3. Except as otherwise shown, fabricate from structural steel shapes and plates and steel bars of welded construction using mitered joints for field connection. Cut, drill, and tap units to receive hardware and similar items.
- 4. Completed layers shall have a smooth, tight and uniform surface reasonably true to the line, grade and cross section as shown on the drawings.

#### B. Accessories:

- 1. Fastenings, connectors, flanges, radius ells, and accessories as specified, detailed, or required for complete installation:
  - a. Sleeve seams in running pipe.
  - b. Inside Radius Ells: Seamless steel, as detailed, and to suit conditions of installation.
  - c. Connectors: Coped, drive-on type, welded.
  - d. Wedge-lock Welding Connectors: Types to suit conditions and as recommended by manufacturer.
  - e. End Caps and Cover Caps: As detailed and to suit conditions of installation.
  - f. Connectors: Steel, types as detailed to suit conditions of installation.
  - g. Other components to be as manufactured or fabricated to suit installation.

### 2.04 FABRICATION TOLERANCES

- A. Squareness: 1/8-inch maximum difference in diagonal measurements.
- B. Maximum Offset Between Faces: 1/16 inch.

## SPECIFICATIONS

**Greenbridge Apt. Buildings A, B & C**

**Contract Number: AW2501531**

**Walkway Repairs**

Page 19 of 30

- C. Maximum Misalignment of Adjacent Members: 1/16 inch.
- D. Maximum Bow: 1/8 inch in 48 inches.
- E. Maximum Deviation From Plane: 1/16 inch in 48 inches.

### · PART 3 EXECUTION

#### 3.01 EXAMINATION

- A. Verify that field conditions are acceptable and are ready to receive work.
- B. Installer must examine areas and conditions under which metal fabrications are to be installed. Notify the Contractor of conditions that are detrimental to the proper and timely completion of the work. Do not proceed with the Work until unsatisfactory conditions have been corrected in a manner acceptable to the installer.

#### 3.02 PREPARATION

- A. Protect surrounding areas and surfaces to preclude damage during work of this Section.
- B. Supply setting templates to the appropriate entities for steel items required to be cast into concrete.

#### 3.03 INSTALLATION

- A. Install items plumb and level, accurately fitted, free from distortion or defects.
- B. Provide for erection loads, and for sufficient temporary bracing to maintain true alignment until completion of erection and installation of permanent attachments.
- C. Fastening to In-Place Construction: Provide anchorage devices and fasteners where necessary for securing metal fabrications to in-place construction including threaded fasteners for concrete inserts, toggle bolts, through-bolts, and other connectors as required. See Architectural and Structural drawings.
- D. Cutting, Fitting and Placement:
  - 1. Perform cutting, drilling and fitting required for installation of metal fabrications. Set work accurately in location, alignment and elevation, plumb, level, true and free of rack, measured from established lines and levels with lines visually parallel. Provide temporary bracing or anchors in framework for items that are to be built into concrete, masonry or similar construction.
  - 2. Fit exposed connections accurately together to form tight hairline joints. Weld connections that are not to be left as exposed joints but cannot be shop welded because of shipping size limitations. Grind joints smooth. Do not weld, cut or abrade the surfaces of exterior units that have been hot-dip galvanized after fabrication, and are intended for bolted or screwed field connections. Galvanize repair paint at welds is not permitted on surfaces exposed to view.
- E. Perform field welding in accordance with AWS D1.1/D1.1M.

## SPECIFICATIONS

**Greenbridge Apt. Buildings A, B & C**

**Contract Number: AW2501531**

**Walkway Repairs**

Page 20 of 30

F. Obtain approval prior to site cutting or making adjustments not scheduled.

### **3.04 CLEAN UP**

A. Leave premises clean and free from residue of work of this Section ready for field coating of section 09 91 13 0 - Exterior Painting.

END OF SECTION

# SPECIFICATIONS

**Greenbridge Apt. Buildings A, B & C**

**Contract Number: AW2501531**

**Walkway Repairs**

Page 21 of 30

## SECTION 061000 - ROUGH CARPENTRY

### PART 1 - GENERAL

#### 1.1 SUMMARY

- A. This Section includes the following:
  - 1. Plywood sheathing
  - 2. Blocking
  - 3. Engineered Wood Products
  - 4. Glued Laminated Lumber

### PART 2 - PRODUCTS

#### 2.1 WOOD PRODUCTS, GENERAL

- A. General wood framing notes;
  - 1. Minimum nailing shall be in accordance with fastening schedule tables 11-13 in ICC-ES evaluation report ESR-1539.
  - 2. Provide cut washers for all bolt heads and nuts bearing on wood.
  - 3. Current WSBC building codes are available online for free public access at [codes.iccsafe.org](http://codes.iccsafe.org).
- B. Lumber: All lumber shall be graded in accordance with current WWPA standard grading rules for western lumber. Use the following species and minimum grade:
  - 1. Blocking Hem-Fir #1 Fb=975 PSI or #2 Fb=850 PSI

#### 2.2 ENGINEERED WOOD PRODUCTS

- A. PSL engineered wood shall be manufactured by Weyerhaeuser in accordance with ICC-ES ESR-1387. Alternate manufacturers require engineers' approval prior to fabrications to use the following minimum grade.
  - 1. Parallam PSL Beams: Grade 2.2E Fb = 2900 PSI

#### 2.3 GLUED LAMINATED LUMBER

- A. Douglass fir-larch grade 24F-V4 (FB=2400 PSI) for single span beams. All glulam materials shall conform to the requirements of ANSI/AITC A190.1 and be stamped with an AITC quality mark or an APA-EWS trademark. Adhesives used in the glulam manufacturing process shall conform to AITC 405 for wet use adhesives. Glulam members shall be manufactured from Douglas Fir Laminating Lumber. All Beams shall have zero camber unless noted otherwise. Members exposed to view in the completed work shall be architectural appearance grade.

#### 2.4 SHEATHING

- A. General:
  - 1. All sheathings shall be APA performance rated panels. Sheathing shall be plywood or oriented strand board (OSB). Bond Classification shall be 'Exposure 1' where protected

## SPECIFICATIONS

**Greenbridge Apt. Buildings A, B & C**

**Contract Number: AW2501531**

**Walkway Repairs**

Page 22 of 30

from the weather. Bond classification shall be exterior where exposed, such as eave and siding applications. All abutting panels shall have 1/8" gap.

B. Walkway Sheathing;

1. Apply plywood to match existing thickness 23/32" min. nailed to joists with 10d ring shank nails at 6" O.C. at all supported panel edges and at 12" O.C. along intermediate supports. Unsupported panel edges shall be tongue-and-groove or blocked. The cut edges of existing sheathing panels should be blocked. New floor sheathing to span across a minimum of three supports.

2.5 FASCIA BOARDS

- A. 1" x 8" Fiber cement board fascia, pre primed all surfaces, final painted after installation to match existing.

2.6 MISCELLANEOUS MATERIALS

A. Fasteners:

1. Where rough carpentry is exposed to weather, in ground contact, or in area of high relative humidity, provide fasteners with hot-dip zinc coating complying with ASTM A 153/A 153M.
2. Power-Driven Fasteners: CABO NER-272.
3. Plywood clips: Installed mid-span between all rafters.

### PART 3 - EXECUTION

3.1 INSTALLATION

- A. Set rough carpentry to required levels and lines, with members plumb, true to line, cut, and fitted. Fit rough carpentry to other construction; scribe and cope as needed for accurate fit.
- B. Patch all high and low static vent locations.
- C. Securely attach rough carpentry work to substrate by anchoring and fastening as indicated, complying with the following:
1. IRC Section R905.2.6. Fastening Methods.
  2. Sheathing: Nail to wood framing.
  3. Fascia: Galvanized or stainless-steel nails

END OF SECTION 061000

# SPECIFICATIONS

**Greenbridge Apt. Buildings A, B & C**

**Contract Number: AW2501531**

**Walkway Repairs**

Page 23 of 30

## SECTION 07600 - SHEET METAL FLASHING AND TRIM

### PART 1 - GENERAL

#### 1.1 SUMMARY

- A. This Section includes the following:
  - 1. Deck Edge Flashing.
  - 2. Deck to Wall Flashing.
  - 3. Saddle Flashing
  - 4. Beam and Post caps.
  - 5. Additional metal flashings as noted in drawings.

#### 1.2 SUBMITTALS

- A. Product Data: For each product indicated.
  - 1. SDS.
  - 2. Shop Drawings (as required)
  - 3. O&M
- B. Manufacturer: for each product indicated.
  - 1. Product Identification Number
- C. Locations for Use: for each product indicated.
  - 1. Typical Use
  - 2. Typical Location
- D. Reference to Drawings Detail or Specification Section.
  - 1. Detail Requiring Product.
  - 2. Specification Requiring Product

#### 1.3 QUALITY ASSURANCE

- A. Sheet Metal Flashing and Trim Standard: Comply with SMACNA's "Architectural Sheet Metal Manual." Conform to dimensions and profiles shown unless more stringent requirements are indicated.

### PART 2 - PRODUCTS

#### 2.1 FLASHING

- A. 24-gauge min. zinc galvanized complying with ASTM A-93 coating not less than 1.50-ounce zinc coating per sq. ft. (total for both sides), with pre-painted finishes on exposed surface. ("Kynar" color to match deck coatings).

## SPECIFICATIONS

**Greenbridge Apt. Buildings A, B & C**

**Contract Number: AW2501531**

**Walkway Repairs**

Page 24 of 30

- B. Fabricate sheet metal flashing and trim to comply with recommendations in SMACNA's "Architectural Sheet Metal Manual" that apply to design, dimensions, metal, and other characteristics of item.
  - 1. Minimum pre-primed 24 gauge hot-dipped galvanized steel sheet, or aluminum.
    - a. Include folded hem on all exposed flashing.
  - 2. Post and Beam flashing.
  - 3. Fasteners: Hot-dipped galvanized or stainless steel as required to penetrate minimum 1-1/4 inch into solid backing.

### PART 3 - EXECUTION

#### 3.1 FLASHING INSTALLATION

- A. General: Install sheet metal deck and wall flashing and to comply with performance requirements and SMACNA's "Architectural Sheet Metal Manual." Provide concealed fasteners where possible, set units true to line, and level as indicated. Install work with laps, joints, and seams that will be permanently watertight.
- B. Refer to drawings for additional installation requirements.

**END OF SECTION 07600**

# SPECIFICATIONS

**Greenbridge Apt. Buildings A, B & C**

**Contract Number: AW2501531**

**Walkway Repairs**

Page 25 of 30

## SECTION 09911 - EXTERIOR PAINTS AND COATINGS

### PART 1 - GENERAL

#### 1.1 SECTION INCLUDES

- A. Surface preparation and field painting of exposed exterior items and surfaces.
  - 1. Wood
    - a. Handrails
    - b. Vertical wood trim.
    - c. Any previously painted wood
  - 2. Fiber Cement Siding & Trim
  - 3. Metal
    - a. Post and Beam Flashings
    - b. Deck Edge Flashing
    - c. All structural steel under stairs
  - 4. Deck Coatings
    - a. Coatings for entire walkway
  - 5. Excluded
    - a. Decorative Railing at stair tower
    - b. All materials not affected by work UNO.

#### 1.2 REFERENCES

- A. ASTM D 16 - Standard Terminology Relating to Paint, Varnish, Lacquer, and Related Products.
- B. ASTM D 3359 - Standard Test Methods for Measuring Adhesion by Tape Test.
- C. ASTM D 1653 - Standard Test Methods for Water Vapor Transmission of Organic Coating Films.
- D. ASTM E-96 - Standard Test Methods for Water Vapor Transmission of Materials.
- E. SSPC, The Society for Protective Coatings - Web Site <http://www.sspc.org>:
  - 1. SSPC-SP1 Solvent Cleaning.
  - 2. SSPC-SP2 Hand Tool Cleaning.
  - 3. SSPC-SP3 Power Tool Cleaning.
  - 4. SSPC-SP7 Brush-Off Blast Cleaning.
- F. PDCA Paint and Decorating Contractors of America - Web Site <http://www.pdca.org>:
  - 1. PDCA Standards P1 through P15

#### 1.3 SUBMITTALS

- A. Product Data: Manufacturer's data sheets on each product to be used, including:
  - 1. Preparation instructions and recommendations.
  - 2. Storage and handling requirements and recommendations.
  - 3. Installation methods.

## SPECIFICATIONS

**Greenbridge Apt. Buildings A, B & C**

**Contract Number: AW2501531**

**Walkway Repairs**

Page 26 of 30

- B. Finish Schedule: Submit finish schedule including color information, gloss and model number for each type and color of finish specified.
- C. Verification Samples: For each finished product specified, two samples, minimum size 6 inches square, representing actual product, color, and patterns.

### 1.4 QUALITY ASSURANCE

- A. Manufacturer Qualifications: All primary products specified in this section will be supplied by a single manufacturer with a minimum of ten years' experience.
- B. Installer Qualifications: All products listed in this section need to be installed by a single installer with a minimum of five years demonstrated experience in installing finishes and coatings of the same type and scope as specified.

### 1.5 DELIVERY, STORAGE, AND HANDLING

- A. Store products in manufacturer's unopened packaging until ready for installation.
- B. Store and dispose of solvent-based materials, and materials used with solvent-based materials, in accordance with requirements of local authorities having jurisdiction.
- C. Take special safety precautions against hazards from toxic and flammable materials.
- D. Place paint and solvent contaminated cloths and materials, subject to spontaneous combustion, in containers and remove from job site each day.
- E. Keep open flame, electrical and static spark, and other ignition sources from flammable vapors and materials at all times.

### 1.6 PROJECT CONDITIONS

- A. Maintain environmental conditions (temperature, humidity, and ventilation) within limits recommended by manufacturers for optimum results. Do not install products under environmental conditions outside manufacturer's recommended limits.
- B. Post "WET PAINT" signs during application and curing of all coatings that may be accessed by other trades or the public.
- C. Post "NO SMOKING" signs during application and curing of solvent-based materials.

### 1.7 COORDINATION

- A. Coordinate Work with other operations and installation of finished materials to avoid damage to installed materials.
- B. Do not apply coating materials until moisture or dust-producing work or other appearance or performance impairing construction activities have been completed.

### 1.8 WARRANTY

- A. At project closeout, provide to Owner an executed copy of the manufacturer's standard limited warranty against manufacturing defect, outlining its terms, conditions, and exclusions from coverage.

## SPECIFICATIONS

**Greenbridge Apt. Buildings A, B & C**

**Contract Number: AW2501531**

**Walkway Repairs**

Page 27 of 30

1. Include final written approval from paint manufacturer's representative that the product has been applied in accordance with the manufacturer's instructions as required to obtain manufacturer's standard limited warranty.

### PART 2 - PRODUCTS

#### 2.1 MATERIALS

- A. Materials selected for coating systems for each type of surface shall be the product of a single manufacturer.
- B. Do not thin finish coats without the manufacturer's approval.
- C. Unsuitability of specified products: Claims concerning the unsuitability of any material specified or inability to satisfactorily produce the work will not be entertained, unless such claim is made in writing to Owner before work is started.
- D. The number of coats scheduled is minimum. Apply additional coats at no additional cost if necessary to completely hide base materials, produce uniform color, and provide satisfactory finishing result.

#### 2.2 PAINT MANUFACTURERS

- A. Acceptable Manufacturer: The Sherwin-Williams Company
  1. Representative – Andrew Dickson  
Phone: 253-258-1560  
Email: [andrew.dickson@sherwin.com](mailto:andrew.dickson@sherwin.com)

#### 2.3 DECK COATING

- A. Rhino Lining – Rhino Lining Extreme
  1. **For bidding purposes, bid price for installing Rhino Lining Extreme instead of the Polycoat 150 mentioned in the Bid Set Preliminary Drawings (4- Plans)**
- B. Polycoat Products -- Polydeck 150/150SC
- C. Include primer as recommended by the manufacturer selected.

### PART 3 - EXECUTION

#### 3.1 EXAMINATION

- A. Examine surfaces scheduled to receive paint and finishes for conditions that will adversely affect execution, permanence or quality of work and which cannot be put into acceptable condition through preparatory work as included in Article 3.2 "Preparation ". Notify Owner in writing of any defects or conditions which will prevent a satisfactory installation.
- B. Examine surfaces scheduled to be finished prior to commencement of work. Report any condition that may affect proper application.
- C. Maximum Moisture Content of Substrates: When measured with an electronic moisture meter as follows;
  1. Concrete: 12 percent
  2. Portland Cement Plaster and Stucco: 12 percent

## SPECIFICATIONS

**Greenbridge Apt. Buildings A, B & C**

**Contract Number: AW2501531**

**Walkway Repairs**

Page 28 of 30

3. Masonry (Clay and CMU): 12 percent
4. Wood: 15 percent
5. Gypsum Board: 12 percent

- D. Verify suitability of substrates, including surface conditions and compatibility with existing finishes and primers.
- E. Proceed with surface preparation and coating application only after unsatisfactory conditions have been corrected.
  1. Application of coating is construed as acceptance of surfaces and conditions.

### 3.2 PREPARATION

- A. Clean surfaces thoroughly prior to coating application.
- B. Masking: All masking over windows in occupied units shall be removed at the end of each workday.
- C. Do not start work until surfaces to be finished are in proper condition to produce finished surfaces of uniform, satisfactory appearance.
- D. Stains and Marks: Remove completely, if possible, using materials and methods recommended by coating manufacturer; cover stains and marks which cannot be completely removed with isolating primer or sealer recommended by coating manufacturer to prevent bleed-through.
- E. Remove Mildew, Algae, and Fungus using materials and methods recommended by coating manufacturers.
- F. Remove dust and loose particulate matter from surfaces to receive coatings immediately prior to coating application.
- G. Remove or protect adjacent hardware, electrical equipment plates, mechanical grilles and louvers, lighting fixture trim, fabric canopies, and other items not indicated to receive coatings.
- H. Move or protect equipment and fixtures adjacent to surfaces indicated to receive coatings to allow application of coatings.
- I. Protect adjacent surfaces not indicated to receive coatings.
- J. Prepare surfaces in accordance with manufacturer's instructions for specified coatings and indicated materials, using only methods and materials recommended by coating manufacturer.

### 3.3 SURFACE PREPARATION

- A. All surfaces to be painted shall be washed.
- B. Mildew
  1. A solution of 1-part Jomax house cleaner and mildew killer concentrate and 1 part water will be applied by a low-pressure system such as:
    - a. Gallon pressure sprayer
    - b. Juice box
    - c. Very low-pressure airless sprayer with little or no "bounce back".
  2. All surfaces will be wetted with this mildewcide solution, not just the most easily accessible. Do not allow this solution to dry before rinsing thoroughly with clean water.

## SPECIFICATIONS

**Greenbridge Apt. Buildings A, B & C**

**Contract Number: AW2501531**

**Walkway Repairs**

Page 29 of 30

- C. Metal: Pressure wash and then sand, wire brush, or scrape as necessary to remove excess rust scale and loose/peeling paint not removed initial cleaning. Prime all bare metal as soon as possible after preparation.
- D. All other surfaces: Pressure wash and scrape to remove dirt contaminants, dust, and loose/peeling paint to provide a smooth surface for paint application. Hammer all protruding nail heads flush with surface before painting. Prime all bare wood areas before applying the finish coat. Caulk any open miters or cracks in surface.
- E. Any debris or chemical residue on windows due to power wash operation will be removed by thoroughly rinsing the windows and surrounding trim. Due care is to be exercised around window seals to prevent damage. Protect all vehicles, other surfaces or plants which will not be receiving paint, but which might be harmed by chemical exposure. Temporary coverings are normally the preferred method.
- F. All washed surfaces will have at least two days of continuous drying time (no rain). Surfaces to be painted must have no more than 13% moisture content before priming and painting commences. Washing one day and painting the next is not acceptable.
- G. The Owner's Representative and paint manufacturer's representative shall inspect preparation prior to the application of paint finishes. Contractor will rework surfaces not properly prepared to receive paint finishes to the satisfaction of the either.

### APPLICATION - GENERAL

- H. Apply each coat to uniform coating thickness in accordance with manufacturer's instructions, not exceeding manufacturer's specified maximum spread rate for indicated surface; thins, brush marks, roller marks, orange-peel, or other application imperfections are not permitted.
- I. Allow the manufacturer's specified drying time, and ensure correct coating adhesion, for each coat before applying the next coat.
- J. Inspect each coat before applying the next coat; touch-up surface imperfections with coating material, feathering, and sanding if required; touch-up areas to achieve flat, uniform surface without surface defects visible from 5 feet.
- K. Do not apply succeeding coat until Owner and paint manufacturer's representative has approved previous coat; only approved coats will be considered in determining number of coats applied.
- L. Remove dust and other foreign materials from substrate immediately prior to applying each coat.
- M. Where coating application abuts other materials or other coating colors, terminate coating with a clean sharp termination line without coating overlap.
- N. Where color changes occur between adjoining spaces, through framed openings that are of same color as adjoining surfaces, change color at outside top corner nearest to face of closed door.
- O. Re-prepare and re-coat unsatisfactory finishes; refinish entire area to corners or other natural terminations.
- P. Disconnect downspouts from building during application to ensure adequate coverage of trim or siding. Re attach immediately after application.

## SPECIFICATIONS

**Greenbridge Apt. Buildings A, B & C**

**Contract Number: AW2501531**

**Walkway Repairs**

Page 30 of 30

### 3.4 DECK COATINGS

- A. Deck coatings shall be installed in accordance with the manufacturer's written instructions.
- B. Apply primer and topcoats as directed by the manufacturer's representative.
- C. Apply thickness as recommended for plywood decking.
- D. Perform pull test prior to complete coating of surfaces.

### 3.5 CLEANING

- A. Clean excess coating materials, and coating materials deposited on surfaces not indicated to receive coatings, as construction activities of this section progress; do not allow them to dry.
- B. Re-install hardware, electrical equipment plates, mechanical grilles and louvers, lighting fixture trim, and other items that have been removed to protect from contact with coatings.
- C. Reconnect equipment adjacent to surfaces indicated to receive coatings.
- D. Relocate to original position equipment and fixtures that have been moved to allow application of coatings.
- E. Remove protective materials.

### 3.6 PROTECTION

- A. Protect completed coating applications from damage by subsequent construction activities.
- B. Repair to Owner's acceptance coatings damaged by subsequent construction activities. Where repairs cannot be made to Owner's acceptance, re-apply finish coating to nearest adjacent change of surface plane, in both horizontal and vertical directions.

### 3.7 COLORS

- A. Colors shall be selected from mockups and shall consist of a field color, trim color and door color.

**END OF SECTION 099000**

**SECTION 01 1000  
SUMMARY**

PART 1 GENERAL

1.1 RELATED DOCUMENTS

- A. Drawings and general provisions of the Contract, including General and Supplementary Conditions and other Division 01 Specification Sections, apply to this Section.

1.2 SUMMARY

- A. This Section includes the following:
1. Work covered by the Contract Documents.
  2. Phased construction.
  3. Work under other contracts.
  4. Owner-furnished products.
  5. Owner's occupancy requirements.
  6. Applicable Codes.
  7. Reference standards.
  8. Use of premises and work restrictions.
  9. Specification formats and conventions.
  10. Execution, correlation and intent – Contract Documents.

1.3 WORK COVERED BY CONTRACT DOCUMENTS

- A. Project Identification:
1. Project Name: Greenbridge Apt. Buildings A, B, & C Walkway Repairs
  2. Project Location: 9915 7th Ave. Seattle, WA. 98106
- B. Owner/Developer: King County Housing Authority
1. Owner's Representative: Antoni Walker
  2. Contact Phone: 206-940-9781
- C. Architects / Engineer:
1. Representative: Nathan Lee Fritz
  2. Contact Phone: 206-281-7500
- D. Reference Section A of the Bid Documents for scope of work.

1.4 PHASED CONSTRUCTION

- A. Construction shall be phased to accommodate Owner's desired schedule as noted in the bid documents and/or drawings, if applicable. Final Project Schedule shall include

phasing schedule to be prepared by the Contractor, and reviewed and approved by the Owner.

- B. Contractor shall prepare a phasing plan to maintain access to residential units during construction. Plan to be reviewed and approved by Owner prior to Work commencing.
- C. Before commencing Work of each phase of construction, submit an updated copy of Contractor's Final Project Schedule showing the sequence, commencement and completion dates, and move-out and -in dates of residents for all phases of the Work.

#### 1.5 WORK UNDER OTHER CONTRACTS

- A. General: Cooperate fully with separate contractors so work on those contracts may be carried out smoothly, without interfering with or delaying work under this Contract. Coordinate the Work of this Contract with work performed under separate contracts.

#### 1.6 OWNER-FURNISHED PRODUCTS

- A. Owner will furnish products as indicated. This section includes receiving, unloading, handling, storing, protecting, and installing Owner-furnished products.
- B. Owner-Furnished Products:
  - 1. Products and materials as noted on drawings or otherwise indicated for re-use.
  - 2. Products and materials as noted on drawings or otherwise indicated to be supplied by Owner.

#### 1.7 OWNER'S OCCUPANCY REQUIREMENTS

- A. Owner Occupancy of Completed Areas of Construction: Owner reserves the right to occupy and to place and install equipment in completed areas of the building before Substantial Completion. Such placement of equipment and partial occupancy shall not constitute acceptance of the total Work. PRIOR to partial Owner Occupancy:
  - 1. Owner will prepare a Certificate of Substantial Completion for each specific portion of the Work to be occupied.
  - 2. Contractor is responsible for obtaining a Certificate of Occupancy from authorities having jurisdiction before Owner occupancy.
  - 3. The mechanical and electrical systems shall be fully operational; all required tests and inspections shall be successfully completed for areas to be occupied. On occupancy, Owner will operate and maintain mechanical and electrical systems serving the occupied portions of building.
  - 4. On occupancy, Owner will assume responsibility for maintenance and custodial service for the occupied portions of building.
  - 5. Coordinate insurance requirements with Owner prior to Owner occupancy of completed areas of the building.

#### 1.8 CUTTING & PATCHING – Refer to Section 01 7329 – Cutting and Patching.

#### 1.9 APPLICABLE CODES

- A. Perform all Work in accordance with the current code requirements of the city holding jurisdiction over the site where Work is to be completed.

- B. Certification of Code Compliance: All materials, methods and equipment shall comply with requirements of applicable codes and the Contract Documents, including requirements of all incorporated standards. The Contractor shall furnish, as a part of the Contract, certification of such compliance if requested by the Architect or the Code Enforcing Agency. Such certification shall be submitted in the form of test results or other data from a recognized independent testing laboratory. Contractor shall coordinate and provide all required submittals to the Code Enforcing Agency in a timely manner so as to not delay progress of the Project.

#### 1.10 USE OF PREMISES AND WORK RESTRICTIONS

- A. General: Contractor shall have full use of premises for construction operations subject to phased construction requirements as specified in this Section and as indicated on Drawings by the Contract limits.
  - 1. Security Procedures: Refer to the Scope of Work Division 1, Section 4 Safety, Protection & Restoration and 01 5000 Temporary Facilities and Controls, for required security procedures to be followed while working at this building.
  - 2. Contractor Identification: All Contractors on site shall be easily identifiable and must wear clothing, name badges, hardhats, safety vests, or other visible identification or identifying article (approved by Owner) with employee's, laborer or staff member's company logo or company name.
- B. Use of Site: Limit use of premises to areas within the Contract limits indicated. Do not disturb portions of Project site beyond areas in which the Work is indicated.
  - 1. Limits: Confine construction operations to areas as indicated on drawings.
- C. Use of Parking Lot: Limited.
- D. Work Restrictions, General: Comply with restrictions on construction operations.
  - 1. Comply with limitations on use of public streets and with other requirements of authorities having jurisdiction.
- E. On-Site Work Hours: Work in the existing occupied buildings will start no earlier than 8:00am, and will be completed by 4:30pm. Hours for work performed outside of the building will be at the discretion of Owner's Representative.
  - 1. Early Morning Hours: As approved by Owner's representative.
  - 2. Hours for Utility Shutdowns: Notify Owner and all affected utility companies seventy-two (72) hours in advance of proposed shutdown.
  - 3. Contractor to notify residents of Work a minimum of forty-eight (48) hours prior to start of Work.
    - a. If Work progress or new work affects additional or a new set of residents, the Contractor must give a new notice of work to all affected residences a minimum of forty-eight (48) hours prior to start of Work.
  - 4. Hours for Core Drilling and other loud activities must comply with city of jurisdiction's noise codes.
- F. Nonsmoking Properties. All of King County Housing Authority properties are nonsmoking.

- G. Controlled Substances: Use of tobacco products and other controlled substances on Project site is not permitted.
- H. Employee Screening: Comply with Owner's requirements for drug and background screening of Contractor personnel working on Project site.
  - 1. Maintain list of approved screened personnel with Owner's representative.

#### 1.11 SPECIFICATION FORMATS AND CONVENTIONS

- A. Specification Format: The Specifications are organized into Divisions and Sections using the 33-division format and CSI/CSC's "2010 Master Format" numbering system.
  - 1. Division 01: Sections in Division 01 govern the execution of the Work of all Sections in the Specifications.
- B. Specification Content: The Specifications use certain conventions for the style of language and the intended meaning of certain terms, words and phrases when used in particular situations. These conventions are as follows:
  - 1. Abbreviated Language: Language used in the Specifications and other Contract Documents is abbreviated. Words and meanings shall be interpreted as appropriate. Words implied, but not stated, shall be inferred as the sense requires. Singular words shall be interpreted as plural and plural words shall be interpreted as singular, where applicable, as the context of the Contract Documents indicates.
  - 2. Imperative mood and streamlined language are generally used in the Specifications. Requirements expressed in the imperative mood are to be performed by Contractor. Occasionally, the indicative or subjunctive mood may be used in the Section Text for clarity to describe responsibilities that must be fulfilled indirectly by Contractor or by others when so noted.
    - a. The words "shall," "shall be," or "shall comply with," depending on the context, are implied where a colon (:) is used within a sentence or phrase.

#### 1.12 EXECUTION, CORRELATION AND INTENT – CONTRACT DOCUMENTS

- A. General: If there is a discrepancy between Scope of Work, Specifications and/or Drawings, the Scope of Work shall take precedence followed by the Specifications and lastly the drawings. Contact Owner immediately for clarification of conflicts, corrections and clarifications.

PART 2 PRODUCTS (Not Used)

PART 3 EXECUTION (Not Used)

**END OF SECTION 01 1000**

## SECTION 01 2600 CONTRACT MODIFICATION PROCEDURES

### PART 1 GENERAL

#### 1.1 RELATED DOCUMENTS

- A. Drawings and general provisions of the Contract, including General and Supplementary Conditions and other Division 01 Specification Sections, apply to this Section.

#### 1.2 SUMMARY

- A. Section includes administrative and procedural requirements for handling and processing Contract Modifications.
- B. Related Sections:
  - 1. Division 01 Section "Product Requirements" for administrative procedures for handling requests for substitutions made after Contract award.

#### 1.3 MINOR CHANGES IN THE WORK

- A. Reference Article 7 in the General Conditions.

#### 1.4 PROPOSAL REQUESTS

- A. The Contractor will have ten (10) calendar days from first notification to supply Owner with the information outlined in this section.
- B. Owner-Initiated Change Order Requests (COR): Contractor will issue a detailed description of:
  - 1. Proposed changes in the Work that may require adjustment to the Contract Sum or the Contract Time. If necessary, the description will include supplemental or revised Drawings and Specifications.
  - 2. Change Order Requests (COR) and Construction Change Directives (CCD) shall be initiated by the Owner, dated and sequentially numbered on Owner provided forms.
  - 3. CORs are not instructions either to stop Work in progress or to execute the proposed change.
  - 4. After receipt of COR, submit a quotation estimating cost adjustments to the Contract Sum and the Contract Time necessary to execute the change.
    - a. Provide a cost breakdown, including overhead and profit as a separate line item, and time extension request as provided for in Article 7 of The General Conditions.
    - b. Provide all necessary product information, specifications, etc. required to justify any Contractor requested changes.
  - 5. The allowed markup shall cover all indirect project costs, including but not limited to, the project Overhead, Profit and General Conditions
    - a. The Contractor shall be allowed a maximum of fourteen (14%) percent Overhead, Profit, and General Conditions, on the cost of craft labor,

- equipment, small tools and materials for self-performed Change Order work.
- b. The Contractor shall be allowed a maximum of eight (8%) percent Overhead, Profit and General Conditions on the cost of craft labor, equipment, small tools and materials for Subcontractor Change Order work. The Contractor is not allowed to take profit on the profit of the Subcontractor as stated in form HUD-5370, section 29.
  - c. A Subcontractor shall be allowed a maximum of fourteen (14%) percent of the cost of craft labor, equipment, materials and small tools for Overhead, Profit and General Conditions, for self-performed Change Order work.
  - d. A Lower-Tier Subcontractor shall be allowed a maximum of fourteen (14%) percent of the cost of craft labor, equipment, materials and small tools for Overhead, Profit and General Conditions, for self-performed Change Order work.
6. Include a list of quantities of products required (or eliminated) their unit costs and a total amount of purchases and credits to be made. If requested, furnish survey data to substantiate quantities.
  7. Indicate applicable taxes, delivery charges, equipment rental and amounts of trade discounts.
  8. Include costs of labor and supervision directly attributable to the change.
  9. Include an updated Contractor's Final Project Schedule that indicates the effect of the change, including but not limited to, changes in activity duration, start and finish times, and activity relationship. Use available total float before requesting an extension of the Contract Time.
    - a. Time extension requests must demonstrate the impact on the project Critical Path Schedule. See the General Conditions Article 15 and Section 01 3200 - Construction Progress Documentation.
  10. Review all pricing provided by subcontractors and suppliers for accuracy and completeness. Verify that their scope of work is consistent with the requested change. Verify math is correct and that markup rates complies with the General Conditions.
  11. After signing the Change Order Request or CCD, the Contractor shall return it to the Owner.
  12. Quotation Form: Use forms acceptable to Owner.
  13. After review of the Contractor's price, cost breakdown and requested time extension, if any, the Owner will submit for estimation and do one of the following:
    - a. Sign and route for approval.
    - b. Reject and resubmit to the Contractor for pricing correction.
    - c. Revise the Change Order Request or CCD and submit to the Contractor for repricing.
  14. Prior to the Owner's acceptance of Change Order Requests, appropriate personnel shall also review the change requests.
- C. Contractor-Initiated Proposals: If latent or changed conditions require modifications to the Contract, Contractor may initiate a claim by submitting a request for a change to Owner.
1. Include a statement outlining reasons for the change and the effect of the change on the Work. Provide a complete description of the proposed change. Indicate the effect of the proposed change on the Contract Sum and the Contract Time.

2. Provide a cost breakdown, including overhead and profit as a separate line item, and time extension request as provided for in Article 7 of the General Conditions.
3. Provide all necessary product information, specifications, etc. required to justify any Contractor requested changes.
4. Allowances for direct supervision, safety, small tools, overhead and profit are limited by the General Conditions, Article 7.1.1.
5. Include a list of quantities of products required (or eliminated), their unit costs and total amount of purchases and credits to be made. If requested, furnish survey data to substantiate quantities.
6. Indicate applicable taxes, delivery charges, equipment rental and amounts of trade discounts.
7. Include costs of labor and supervision directly attributable to the change.
8. Include an updated Contractor's Final Project Schedule that indicates the effect of the change, including but not limited to, changes in activity duration, start and finish times, and activity relationship. Use available total float before requesting an extension of the Contract Time.
  - a. Time extension requests must demonstrate the impact on the project Critical Path Schedule. See the General Conditions, and Section 01 3200-Construction Progress Documentation.
9. Comply with requirements in Division 01 Section "Product Requirements" if the proposed change requires substitution of one product or system for product or system specified.
10. Proposal Request Form: Use form acceptable to Owner.
11. After review of the Contractor's price, cost breakdown and requested time extension, if any, the Owner will submit for estimation and do one of the following:
  - a. Sign and send on for approval.
  - b. Reject and resubmit to the Contractor for pricing correction.
  - c. Revise the Change Order Request or CCD and submit to the Contractor for repricing.
12. Prior to the Owner's acceptance of Change Order Requests, appropriate personnel shall also review the change requests.

#### 1.5 CONSTRUCTION CHANGE DIRECTIVE (CCD)

- A. The Contractor will have ten (10) calendar days from first notification to supply Owner with the information outlined in this section.
- B. Construction Change Directive: The Owner may issue a Field Authorization in accordance with provisions in Article 7, General Conditions. Construction Change Directive instructs Contractor to proceed with a change in the Work, for subsequent inclusion in a Change Order.
- C. Documentation: Maintain detailed records on a time and material basis of Work required by the CCD, with supporting documentation as required by CORs.
  1. After completion of change, submit an itemized account and supporting data necessary to substantiate cost and time adjustments to the Contract, consistent with Article 7 of the General Conditions of the Contract.

1.6 CHANGE ORDER PROCEDURES

- A. The Contractor will have ten (10) calendar days from first notification to supply Owner with the information outlined in this section.
- B. When approved and signed by the Owner, the Construction Change Directive will either be included in a Change Order Request (COR) to be charged against the Contract Allowance, or will be included in a formal Change Order, which will modify the Contract amount.

PART 2 PRODUCTS (Not Used)

PART 3 EXECUTION (Not Used)

**END OF SECTION 01 2600**

**SECTION 01 2900  
PAYMENT PROCEDURES**

PART 1 GENERAL

1.1 RELATED DOCUMENTS

- A. Drawings and general provisions of the Contract, including General and Supplementary Conditions and other Division 01 Specification Sections, apply to this Section.

1.2 SUMMARY

- A. This Section specifies administrative and procedural requirements necessary to prepare and process Applications for Payment.

1.3 DEFINITIONS

- A. Schedule of Values: A statement furnished by Contractor allocating portions of the Contract Sum to various portions of the Work and used as the basis for reviewing Contractor's Applications for Payment.

1.4 SCHEDULE OF VALUES

- A. Coordination: Coordinate preparation of the Schedule of Values with preparation of Contractor's Master Project Schedule.
  - 1. Correlate line items in the Schedule of Values with other required administrative forms and schedules, including the following:
    - a. Application for Payment forms with Continuation Sheets.
    - b. Submittal Schedule.
  - 2. Submit the Schedule of Values to Owner at earliest possible date but no later than fourteen (14) calendar days after the date of bid opening.
  - 3. Sub-schedules: Where the Work is separated into phases requiring separately phased payments, provide sub-schedules showing values correlated with each phase of payment.
- B. Format and Content: Use the Project Documents as a guide to establish line items for the Schedule of Values. Lines items are based on Scope of Work and sequencing.
  - 1. Identification: Include the following Project identification on the Schedule of Values:
    - a. Project name and location.
    - b. Name of Owner.
    - c. Owner's contract number.
    - d. Contractor's name and address.
    - e. Date of submittal.
  - 2. Arrange the Schedule of Values in tabular form with separate columns to indicate the following for each item listed:

- a. Item #, including separate line for an Allowance (if applicable).
  - b. Description of the Work.
  - c. Total Dollar Value.
  - d. Previous Application Amount.
  - e. Dollar Amount Charged on Current Pay Application.
  - f. Stored Materials.
  - g. Total Complete and Stored.
    - 1) Percentage of the Contract Sum to nearest one-hundredth percent, adjusted to total one hundred (100%) percent.
  - h. Balance to Finish
  - i. Retainage
3. Provide a breakdown of the Contract Sum in enough detail to facilitate continued evaluation of Applications for Payment and progress reports. Coordinate with the Project Documents. Provide several line items for principal subcontract amounts, where appropriate.
  4. Round amounts to nearest one (1) cent; total shall equal the Contract Sum.
  5. Provide a separate line item in the Schedule of Values for each part of the Work where Applications for Payment may include materials or equipment purchased or fabricated and stored, but not yet installed.
    - a. Differentiate between items stored on-site and items stored off-site. Include evidence of insurance or bonded warehousing per Article 9.3.2 AIA A201-2017 General Conditions.
  6. Provide separate line items in the Schedule of Values for initial cost of materials, for each subsequent stage of completion, and for total installed value of that part of the Work.
  7. Each item in the Schedule of Values and Applications for Payment shall be complete. Include total cost and proportionate share of general overhead and profit for each item.
    - a. Temporary facilities and other major cost items that are not direct cost of actual work-in-place may be shown either as separate line items in the Schedule of Values or distributed as general overhead expense, at Contractor's option.
  8. Schedule Updating: Update and resubmit the Schedule of Values before the next Applications for Payment when Change Orders result in a change in the Contract Sum.

#### 1.5 APPLICATIONS FOR PAYMENT

- A. Each Application for Payment shall be consistent with previous applications and payments as certified by Owner and paid for by Owner.
- B. Payment Application Times:
  1. The date for each progress payment is indicated in the Contract between Owner and Contractor.
  2. The period of construction Work covered by each Application for Payment is the period indicated in the Contract.
- C. Payment Application Forms:

1. Use Payment Application forms as provided by Owner for Applications for Payment.
- D. Application Preparation: Complete every entry on form. Notarize and execute by a person authorized to sign legal documents on behalf of Contractor. Owner will return incomplete applications without action.
1. Entries shall match data on the Schedule of Values and Contractor's Final Project Schedule. Use updated schedules if revisions were made.
  2. Include amounts of Change Orders and Construction Change Directives issued before last day of construction period covered by application.
  3. Provide current Subcontractor List with each Application for Payment.
- E. Transmittal: Submit one (1) signed and notarized original Application for Payment to Owner by a method ensuring receipt within forty-eight (48) hours. The Application for Payment shall include intent to pay prevailing wages and a running spreadsheet that itemizes both the intent and affidavit of wages paid to date for each subcontractor.
1. Transmit Application for Payment with a transmittal form listing attachments and recording appropriate information about the application.
- F. General Contractor Certification Upon Application For Payment: Refer to attached Exhibits in Contract.
- G. Initial Application for Payment: Administrative actions and submittals that must precede the first Application for Payment include the following:
1. List of subcontractors. (Required at pre-construction conference.)
  2. Schedule of Values.
  3. Contractor's Final Project Schedule to be created in MS Project or equivalent format. (Required at pre-construction conference.)
  4. Certificates of insurance and insurance policies. (Required prior to contract award.)
  5. Performance and payment bonds. (Required prior to contract award.)
  6. Section 3 Work Plan, for projects whose contract value is five hundred thousand dollars (\$500,000) or higher.
  7. Intent to Pay Prevailing Wages must be filed with L&I.
  8. Contractor to provide Owner with initial Cash Flow Projections. Cash Flow Projection needs to reflect Work as detailed in Final Project Schedule.
- H. **All** Application for Payments will be reviewed for completion and correctness, including reasons outlined in A201-2017 General Conditions.
- I. Application for Payment at Substantial Completion: After Owner issues the Certificate of Substantial Completion, submit an Application for Payment showing one hundred (100%) percent completion for portion of the Work claimed as substantially complete.
1. Include documentation supporting claim that the Work is substantially complete and a statement showing an accounting of changes to the Contract Sum.

2. This application shall reflect Certificates of Partial Substantial Completion issued previously for Owner occupancy of designated portions of the Work.

J. Final Payment Application: Administrative actions and submittals that must precede or coincide with submittal of the final Application for Payment include the following (refer to Article 9.10 in AIA A201-2017 General Conditions:

1. Completion of Project closeout requirements.
2. Completion of Items specified.
3. Ensure that unsettled claims will be settled.
4. Ensure that incomplete Work is not accepted and will be completed without undue delay.
5. Transmittal of required Project construction records to the Owner.
6. Proof that fees and similar obligations were paid.
7. Removal of temporary facilities and services.
8. Removal of surplus materials, rubbish and similar elements.
9. Operations and Maintenance Manuals
10. Record Drawings (i.e. As-built drawings, redline drawings)
11. Final Affidavits of Wages Paid filed with L&I.

1.6 SPECIAL PAYMENT REQUIREMENTS (Not Used)

PART 2 PRODUCTS (Not Used)

PART 3 EXECUTION (Not Used)

**END OF SECTION 01 2900**

**SECTION 01 3100  
PROJECT MANAGEMENT AND COORDINATION**

PART 1 GENERAL

1.1 RELATED DOCUMENTS

- A. Drawings and general provisions of the Contract, including General and Supplementary Conditions and other Division 01 Specification Sections, apply to this Section.

1.2 SUMMARY

- A. This Section includes administrative provisions for coordinating construction operations on Project including, but not limited to, the following:
  - 1. General project coordination procedures.
  - 2. Coordination Drawings.
  - 3. Project meetings.
  - 4. Requests for Information (RFIs).
- B. See Division 01 Section "Execution" for procedures for coordinating general installation and field-engineering services, including establishment of benchmarks and control points.

1.3 DEFINITIONS

- A. RFI: Request from Contractor seeking interpretation or clarification of the Contract Document.

1.4 COORDINATION

- A. Coordination: Contractor's Responsibility to coordinate construction operations included in different Sections of the Specifications to ensure efficient and orderly installation of each part of the Work. Coordinate construction operations, included in different Sections that depend on each other for proper installation, connection and operation.
  - 1. Schedule construction operations in sequence required to obtain the best results where installation of one part of the Work depends on installation of other components, before or after its own installation.
  - 2. Coordinate installation of different components with other contractors to ensure maximum accessibility for required maintenance, service and repair.
  - 3. Make adequate provisions to accommodate items scheduled for later installation.
- B. Administrative Procedures: Coordinate scheduling and timing of required administrative procedures with other construction activities and activities of other contractors to avoid conflicts and to ensure orderly progress of the Work. Such administrative activities include, but are not limited to, the following:
  - 1. Preparation of Contractor's Final Project Schedule.
  - 2. Preparation of the Schedule of Values.
  - 3. Installation and removal of temporary facilities and controls.
  - 4. Delivery and processing of submittals.
  - 5. Progress meetings.

6. Pre-installation conferences.
7. Project closeout activities.

## 1.5 PROJECT MEETINGS

- A. General: Contractor is responsible for scheduling and conducting meetings and conferences at Project site, unless otherwise indicated.
  1. Attendees: Inform participants, others who are involved and individuals whose presence is required, of date and time of each meeting. Notify Owner of scheduled meeting dates and times.
  2. Agenda: Prepare the meeting agenda. Distribute the agenda to all invited attendees.
  3. Minutes: Record significant discussions and agreements achieved. Distribute the meeting minutes to everyone concerned; send the electronic version of the meeting minutes to the Project Manager and the Project Engineer, within three (3) business days of the meeting.
  
- B. Pre-construction Conference: A pre-construction conference shall be scheduled before starting construction. Owner to hold the conference at Project site or another convenient location. Conduct the meeting to review responsibilities and personnel assignments.
  1. Attendees: Authorized representatives of Owner, Architect, and their consultants; Contractor and its superintendent; major subcontractors; suppliers; and other concerned parties shall attend the conference.
  2. Agenda: Owner to discuss items of significance that could affect progress, including the following:
    - a. Scope of Work.
    - b. Contract Start and End Dates.
    - c. Authority of Owner's Personnel.
    - d. Davis Bacon/Prevailing Wage Certified Payroll Reports/Labor Relations and Section 3.
    - e. Insurance Certificate, Endorsement and Performance and Payment Bonds.
    - f. General Requirements/Special Conditions.
    - g. Final Project Schedule, including Phasing.
    - h. Easements, Permits, Lines & Grades.
    - i. Contractor's Superintendent.
    - j. Subcontractor List.
    - k. Safety Plan (see attachment at end of this section).
    - l. Tests, Samples and Observations.
    - m. Progress Meetings and Reports.
    - n. Applications and Certificates of Payment, and Retention.
    - o. Progress Payments.
    - p. Change Orders.
    - q. Warranty Requirements.
    - r. Submittals.
    - s. Temporary and Storage Facilities, Staging Areas and Jobsite Security.
    - t. Clean-up and Trash Removal.
    - u. Salvage of Materials and Spare Materials.
    - v. Record Drawings.
    - w. Substantial Completion, Final Payment and Retainage.
    - x. Recycling and Energy Conservation.

- y. Minutes: The Owner will record and distribute Pre-construction meeting minutes via email.
- C. Progress Meetings: The Contractor will conduct progress meetings at weekly intervals. (refer to Article 3.1.4 of General Conditions).
- 1. Attendees: In addition to representatives of Owner and the Contractor, each subcontractor, supplier and other entity concerned with current progress or involved in planning, coordination, or performance of future activities shall be represented at these meetings. All participants at the conference shall be familiar with Project and authorized to conclude matters relating to the Work.
  - 2. Agenda: Review and correct or approve minutes of previous progress meeting. Review other items of significance that could affect progress. Include topics for discussion as appropriate to status of Project.
    - a. Contractor's Final Project Schedule: Review progress since the last meeting. Determine whether each activity is on time, ahead of schedule, or behind schedule, in relation to Contractor's Final Project Schedule. Determine how construction behind schedule will be expedited; secure commitments from parties involved to do so. Discuss whether schedule revisions are required to ensure that current and subsequent activities will be completed within the Contract Time.
      - 1) Contractor shall provide a short term look-ahead schedule for presentation and review at each progress meeting.
    - b. Review present and future needs of each entity present, including the following:
      - 1) Interface requirements.
      - 2) Sequence of operations.
      - 3) Status of submittals.
      - 4) Deliveries.
      - 5) Off-site fabrication.
      - 6) Access.
      - 7) Site utilization.
      - 8) Temporary facilities and controls.
      - 9) Work hours.
      - 10) Hazards and risks.
      - 11) Progress cleaning.
      - 12) Quality and work standards.
      - 13) Status of correction of deficient items.
      - 14) Field observations.
      - 15) RFIs.
      - 16) Status of proposal requests.
      - 17) Pending changes.
      - 18) Status of Change Orders.
      - 19) Pending claims and disputes.
      - 20) Documentation of information for payment requests.
      - 21) Safety
      - 22) Section 3 compliance and status
  - 3. Minutes: Contractor will record the meeting minutes.
  - 4. Reporting: Contractor will email the minutes to all concerned prior to the meeting and will distribute written copies of the minutes of the meeting to each party present and to parties who should have been present.
    - a. Schedule Updating: Revise Contractor's Two (2)-Week Look Ahead Schedule after each progress meeting. This schedule will be discussed in

each progress meeting. Issue revised schedule concurrently with the report of each meeting.

- b. Contractor's weekly reports will consist of five (5) daily reports, each reflecting the preceding five (5) days. These reports will be sent electronically to the Owner on a schedule that will be determined at the Pre-Construction Meeting or at each progress meeting.

## 1.6 REQUESTS FOR INFORMATION (RFIs)

- A. Procedure: Immediately on discovery of the need for interpretation of the Contract Documents, and if not possible to request interpretation at Project meeting, prepare and submit an RFI in the form specified.
  1. RFIs generated from subcontractor or supplier of the Contractor must be routed through the General Contractor.
  2. Coordinate and submit RFIs in a prompt manner so as to avoid delays in Contractor's work or work of subcontractors.
  3. If a suggestion can be determined or derived at by the initiator of the RFI, it is required the suggestion be supplied with the submitted RFI. If no suggestion is given where one is possible, the RFI will be returned as incomplete.
- B. Content of the RFI: Include a detailed, legible description of item needing interpretation and the following:
  1. Project name and number.
  2. RFI Subject.
  3. Date.
  4. Name of Contractor.
  5. Name of Architect.
  6. RFI number, numbered sequentially.
  7. Specification Section number and title and related paragraphs, as appropriate.
  8. Drawing number and detail references, as appropriate.
  9. Field dimensions and conditions, as appropriate.
  10. Contractor's suggested solution(s). If Contractor's solution(s) impact the Contract Time or the Contract Sum, Contractor shall state impact in the RFI.
  11. Contractor's signature.
  12. Attachments: Include drawings, descriptions, measurements, photos, product data, shop drawings and other information necessary to fully describe items needing interpretation.
- C. Hard-Copy RFIs: Form established by Contractor's Project Management system.
  1. Identify each page of attachments with the RFI number and sequential page number.
- D. Owner's Action: Owner will review each RFI, determine action required and return it. Allow five (5) working days for Owner's acknowledgement of each RFI.
  1. The following RFIs will be returned without action:
    - a. Requests for approval of submittals.
    - b. Requests for approval of substitutions.
    - c. Requests for coordination information already indicated in the Contract Documents.
    - d. Requests for adjustments in the Contract Time or the Contract Sum.
    - e. Requests for interpretation of Owner's actions on submittals.
    - f. Incomplete RFIs or RFIs with numerous errors.

2. Owner's action may include a request for additional information, in which case Owner's time for response will start again.
  3. Owner's action may include architect and/or engineer recommendation or approval of proposed solution.
  4. Owner's action on RFIs that may result in a change to the Contract Time or the Contract Sum may be eligible for Contractor to submit Change Order Request according to General Conditions.
    - a. If Contractor believes the RFI response warrants change in the Contract Time or the Contract Sum, notify Owner in writing within five (5) days of receipt of the RFI response.
- E. On receipt of Owner's action, update the RFI log and immediately distribute the RFI response to affected parties. Review response and notify Owner within three (3) days if Contractor disagrees with response.
- F. Contractor RFI Log: Prepare, maintain and submit a tabular log of RFIs organized by the RFI number. Submit log weekly. Include the following:
1. Project name.
  2. Name and address of Contractor.
  3. Name and address of Architect.
  4. RFI number including RFIs that were dropped and not submitted.
  5. RFI description.
  6. Date the RFI was submitted.
  7. Date Architect's response was received.
  8. Identification of related Minor Change in the Work, Construction Change Directive and Change Order Request, as appropriate.
- PART 2 PRODUCTS (Not Used)
- PART 3 EXECUTION (Not Used)

**GENERAL CONTRACTOR SITE SAFETY PLAN CHECKLIST**

**Instructions:** Please indicate whether or not your Site Safety Plan contains the following provisions.

**Contractors: Site Safety Plan Evaluation**

Yes	No	N/A	
<input type="checkbox"/>	<input type="checkbox"/>	<input type="checkbox"/>	1. Will your company have a written, established, supervised and enforced site safety plan for the project? <i>(The site safety plan must be presented before starting work)</i>
<input type="checkbox"/>	<input type="checkbox"/>	<input type="checkbox"/>	2. Does the site safety plan include an orientation and weekly safety meetings that show your employees and other subcontractors what they need to know to perform their job assignments safely?
<input type="checkbox"/>	<input type="checkbox"/>	<input type="checkbox"/>	3. Does the site safety plan describe how and when to report on-the-job injuries?
<input type="checkbox"/>	<input type="checkbox"/>	<input type="checkbox"/>	4. Does the site safety plan identify on-site available 1st Aid / CPR trained personnel, readily accessible first-aid and and/or access to the nearest clinic or hospital on job site?
<input type="checkbox"/>	<input type="checkbox"/>	<input type="checkbox"/>	5. Does the site safety plan identify what to do in an emergency, including how to exit the workplace?
<input type="checkbox"/>	<input type="checkbox"/>	<input type="checkbox"/>	6. Does the site safety plan explain how employees and other subcontractors report unsafe conditions and practices?
<input type="checkbox"/>	<input type="checkbox"/>	<input type="checkbox"/>	7. Does the site safety plan describe the required personal protective equipment (PPE) and the proper use and care of the PPE?
<input type="checkbox"/>	<input type="checkbox"/>	<input type="checkbox"/>	8. Is there an on-site Haz-com Program that identifies hazardous materials (Asbestos, Lead) or chemicals including instruction about the safe use and storage?
<input type="checkbox"/>	<input type="checkbox"/>	<input type="checkbox"/>	9. Does the site safety plan identify the designated representative responsible for job-site Safety?
<input type="checkbox"/>	<input type="checkbox"/>	<input type="checkbox"/>	10. Does the site safety plan describe who is responsible for performing and recording regular periodic site reviews, and inspections for your employees and subcontractors?
<input type="checkbox"/>	<input type="checkbox"/>	<input type="checkbox"/>	11. Does the site safety plan describe programs related to housekeeping and jobsite safety?
<input type="checkbox"/>	<input type="checkbox"/>	<input type="checkbox"/>	12. Does the site safety plan include a job-site specific written fall protection plan covering potential falls hazards and protections?
<input type="checkbox"/>	<input type="checkbox"/>	<input type="checkbox"/>	13. Does the site safety plan describe electrical and or power generation controls?
<input type="checkbox"/>	<input type="checkbox"/>	<input type="checkbox"/>	14. Does the site safety plan have provisions for trenching /excavations and/or confined space?

**Notes:**

**END OF SECTION 01 3100**

## SECTION 01 3200 CONSTRUCTION PROGRESS DOCUMENTATION

### PART 1 GENERAL

#### 1.1 RELATED DOCUMENTS

- A. Drawings and general provisions of the Contract, including General and Supplementary Conditions and other Division 01 Specification Sections, apply to this Section.

#### 1.2 SUMMARY

- A. This Section includes administrative and procedural requirements for documenting the progress of construction during performance of the Work, including the following:
  - 1. Contractor's Final Project Schedule.
  - 2. Submittals Schedule (refer to Article 3.10.2 in General Conditions AIA A201-2017).
  - 3. Daily construction reports.

#### 1.3 DEFINITIONS

- A. Activity: A discrete part of a project that can be identified for planning, scheduling, monitoring and controlling the construction project. Activities included in a Final Project Schedule consume time and resources.
  - 1. Critical activities are activities on the critical path. They must start and finish on the planned early start and finish times.
  - 2. Predecessor Activity: An activity that precedes another activity in the network.
  - 3. Successor Activity: An activity that follows another activity in the network.
- B. CPM: Critical Path Method, which is a method of planning and scheduling a construction project where activities are arranged based on activity relationships. Network calculations determine when activities can be performed and the critical path of Project.
- C. Critical Path: The longest connected chain of interdependent activities through the network schedule that establishes the minimum overall Project duration and contains no float.
- D. Float: The measure of leeway in starting and completing an activity.
  - 1. Float time is not for the exclusive use or benefit of either Owner or Contractor, but is a jointly owned, expiring Project resource available to both parties as needed to meet schedule milestones and Contract completion date.
- E. Fragnet: A partial or fragmentary network that breaks down activities into smaller activities for greater detail.
- F. Major Area: A story of construction, a separate building or a similar significant construction element.

#### 1.4 SUBMITTALS

- A. Submittals Schedule: Submit one (1) electronic copy of schedule to the Owner. Arrange the following information in a tabular format
  1. Scheduled date for first submittal.
  2. Specification Section number and title.
  3. Submittal category (action or informational).
  4. Name of subcontractor (if applicable).
  5. Description of the Work covered.
  6. Scheduled date for Architect's final release or approval.
- B. Contractor's Final Project Schedule: Submit one (1) electronic copy and one (1) hard copy of initial schedule to the Owner. The hard copy should be large enough to show entire schedule for entire construction period.

#### 1.5 COORDINATION

- A. Coordinate preparation and processing of schedules and reports with performance of construction activities and with scheduling and reporting of separate contractors.
- B. Coordinate Contractor's Final Project Schedule with the Schedule of Values, list of subcontracts, Submittals Schedule, progress reports, payment requests, and other required schedules and reports.
  1. Secure time commitments for performing critical elements of the Work from parties involved.
  2. Coordinate each construction activity in the network with other activities and schedule them in proper sequence.

### PART 2 PRODUCTS

#### 2.1 SUBMITTALS SCHEDULE

- A. Preparation: Submit a schedule of submittals to the Owner, arranged in chronological order by dates required by Final Project Schedule. Include time required for review, resubmittal, ordering, manufacturing, fabrication and delivery when establishing dates.
  1. Coordinate Submittals Schedule with list of subcontracts, the Schedule of Values, and Contractor's Final Project Schedule.
  2. Submit concurrently with the first complete submittal of Contractor's Final Project Schedule.

#### 2.2 CONTRACTOR'S FINAL PROJECT SCHEDULE, GENERAL (refer to Article 3.10.1 in the General Conditions AIA A201)

- A. Contractor to provide a baseline, cost-loaded schedule in MS Project or Primavera to the Owner's Representative one (1) day **prior** to the weekly project meeting. Contractor is to update the schedule weekly.
- B. Time Frame: Extend schedule from date established for commencement of the Work to date of Substantial Completion as set by the date of Notice to Proceed.

1. Contract completion date shall not be changed by submission of a schedule that shows an early completion date, unless specifically authorized by Change Order.
- C. Activities: Treat each story or separate area as a separate numbered activity for each principal element of the Work. Comply with the following:
1. Activity Duration.
  2. Procurement Activities: Include procurement process activities for long lead items and major items as separate activities in schedule.
    - a. Procurement cycle activities include, but are not limited to, submittals, approvals, purchasing, fabrication and delivery.
  3. Submittal Review Time: Include review and resubmittal times indicated in Division 01 Section "Submittal Procedures" in schedule. Coordinate submittal review times in Contractor's Final Project Schedule with Submittals Schedule.
  4. Startup and Testing Time: Include not less than ten (10) days for startup and testing.
  5. Substantial Completion: Indicate completion in advance of date established for Substantial Completion, and allow time for Architect's administrative procedures necessary for certification of Substantial Completion.
- D. Constraints: Include constraints and work restrictions indicated in the Contract Documents and as follows in Final Project Schedule, and show how the sequence of the Work is affected.
1. Phasing: Arrange list of activities on schedule by phase.
  2. Work by Owner: Include a separate activity for each portion of the Work performed by Owner.
  3. Work Restrictions: Show the effect of the following items on the Final Project Schedule:
    - a. Coordination with existing construction.
    - b. Limitations of continued occupancies.
    - c. Uninterruptible services.
    - d. Partial occupancy before Substantial Completion.
    - e. Use of premises restrictions.
    - f. Provisions for future construction.
    - g. Seasonal variations.
    - h. Environmental control.
  4. Work Stages: Indicate important stages of construction for each major portion of the Work.
- E. Milestones: Include milestones indicated in the Contract Documents in Final Project Schedule, including, but not limited to, the Notice to Proceed, Substantial Completion and Final Completion.
- F. Contract Modifications: For each proposed contract modification and concurrent with its submission, prepare a time-impact analysis using fragnets to demonstrate the effect of the proposed change on the overall project schedule.

2.3 CONTRACTOR'S FINAL PROJECT SCHEDULE (GANTT CHART)

- A. Gantt-Chart Schedule: Submit to the Owner a comprehensive, fully developed, horizontal Gantt-chart-type, Contractor's Final Project Schedule within fourteen (14) calendar days of date after Letter of Award. Base schedule on the Preliminary Construction Schedule and whatever updating and feedback was received since the start of Project. The Gantt-Chart Final Project Schedule can be either in MS Project or equivalent format.
- B. Preparation: Indicate each significant construction activity separately. Identify first workday of each week with a continuous vertical line.
  - 1. For construction activities that require three (3) months or longer to complete, indicate an estimated completion percentage in ten (10%) percent increments within time bar.

PART 3 EXECUTION

3.1 CONTRACTOR'S FINAL PROJECT SCHEDULE

- A. Contractor's Final Project Schedule Updating: At two (2) week intervals, update schedule to reflect actual construction progress and activities. Issue schedule three (3) days before each regularly scheduled progress meeting.
  - 1. Revise schedule immediately after each meeting or other activity where revisions have been recognized or made. Issue updated schedule concurrently with the report of each such meeting.
  - 2. Include a report with updated schedule that indicates every change, including, but not limited to, changes in logic, durations, actual starts and finishes, and activity durations.
  - 3. As the Work progresses, indicate Actual Completion percentage for each activity.
- B. Distribution: Distribute electronic copies of approved schedule to Owner, separate contractors, testing and inspecting agencies, and other parties identified by Contractor with a need-to-know schedule responsibility.
  - 1. Post copies in Project meeting rooms and temporary field offices.
  - 2. When revisions are made, distribute updated schedules to the same parties and post in the same locations. Delete parties from distribution when they have completed their assigned portion of the Work and are no longer involved in performance of construction activities.

**END OF SECTION 01 3200**

## SECTION 01 3300 SUBMITTAL PROCEDURES

### PART 1 GENERAL

#### 1.1 RELATED DOCUMENTS

- A. Drawings and general provisions of the Contract, including General and Supplementary Conditions and other Division 01 Specification Sections, apply to this Section.

#### 1.2 SUMMARY

- A. This Section includes administrative and procedural requirements for submitting Shop Drawings, Product Data, Samples and other submittals.
- B. Related Sections:
  - 1. See Division 01 40 00 Section "Quality Requirements" for submitting test and inspection reports and for mockup requirements.
  - 2. See Division 01 77 00 Section "Closeout Procedures" for submitting warranties.
  - 3. See Division 01 78 39 Section "Project Record Documents" for submitting Record Drawings, Record Specifications, and Record Product Data.
  - 4. See Division 01 78 23 Section "Operation and Maintenance Data" for submitting operation and maintenance manuals.

#### 1.3 DEFINITIONS

- A. Action Submittals: Written and graphic information that requires Owner's responsive action.
- B. Informational Submittals: Written information that does not require Owner's responsive action. Submittals may be rejected for not complying with requirements.

### PART 2 PRODUCTS

#### 2.1 SUBMITTAL PROCEDURES

- A. General Submittal Procedure Requirements:
  - 1. Submit electronic submittals to Owner via email as PDF electronic files.
    - a. Owner will return annotated file. Annotate and retain one (1) copy of file as an electronic Project record document file.
- B. Coordination: Coordinate preparation and processing of submittals with performance of construction activities.
  - 1. Coordinate each submittal with fabrication, purchasing, testing, delivery, other submittals and related activities that require sequential activity.
  - 2. Coordinate transmittal of different types of submittals for related parts of the Work so processing will not be delayed because of need to review submittals concurrently for coordination.
    - a. Owner reserves the right to withhold action on a submittal requiring coordination with other submittals until related submittals are received.

- C. Processing Time: Allow enough time for submittal review, including time for resubmittals, as follows:
1. Time for review shall commence on Owner's receipt of submittal. No extension of the Contract Time will be authorized because of failure to transmit submittals enough in advance of the Work to permit processing, including resubmittals.
  2. Initial Review: Allow five (5) working days for initial review of each submittal. Allow additional time if coordination with subsequent submittals is required. Owner will advise Contractor when a submittal being processed must be delayed for coordination.
  3. Intermediate Review: If intermediate submittal is necessary, process it in same manner as initial submittal.
  4. Resubmittal Review: Allow seven (7) working days for review of each resubmittal.
- D. Identification: Place a permanent label or title block on each submittal for identification.
1. Indicate name of firm or entity that prepared each submittal on label or title block.
  2. Provide a space approximately **4 by 5 inches** on label or beside title block to record Contractor's review and approval markings and action taken by Owner.
  3. Include the following information on label for processing and recording action taken:
    - a. Project name.
    - b. Date.
    - c. Name and address of Architect (if applicable).
    - d. Name and address of Contractor.
    - e. Name and address of subcontractor.
    - f. Name and address of supplier.
    - g. Name of manufacturer.
    - h. Submittal number or other unique identifier, including revision identifier.
      - 1) Submittal number shall use consecutively numbered submittals (001, 002, etc), followed by the Specification Section number, followed by a sequential number indicating version (e.g., 001-13 3300-0).
      - 2) Example: 001 – 01 1300 – 0
        - a) 001: Consecutively numbered submittals
        - b) 01 1300: Specification Section
        - c) 0: Version of submittal (0 = original submittal; 1 = first resubmittal; 2 = 2nd resubmittal; etc.)
    - i. Number and title of appropriate Specification Section.
    - j. Drawing number and detail references, as appropriate.
    - k. Location(s) where product is to be installed, as appropriate.
    - l. Other necessary identification.
- E. Deviations: Highlight, encircle or otherwise specifically identify deviations from the Contract Documents on submittals.
1. Substitution Requests.

- F. Additional Copies: Unless additional copies are required for final submittal, and unless Owner observes noncompliance with provisions in the Contract Documents, initial submittal may serve as final submittal.
  - 1. Additional copies submitted for maintenance manuals will not be marked with action taken and will be returned.
  
- G. Transmittal: Package each submittal individually and appropriately for transmittal and handling. Transmit each submittal using a transmittal form. Owner will return submittals, without review, received from sources other than Contractor.
  - 1. Include Contractor's certification stating that information submitted complies with requirements of the Contract Documents.
  
- H. Resubmittals: Make resubmittals in same form and number of copies as initial submittal.
  - 1. Note date and content of previous submittal.
  - 2. Note date and content of revision in label or title block and clearly indicate extent of revision.
  - 3. Resubmit submittals until they are marked "Make Corrections Noted" or "No Exceptions Taken".
  
- I. Distribution: Furnish copies of final submittals to manufacturers, subcontractors, suppliers, fabricators, installers and others as necessary for performance of construction activities. Show distribution on transmittal forms.
  - 1. Use for Construction: Use only final submittals with mark indicating "Make Corrections Noted" or "No Exceptions Taken".

## 2.2 CONTRACTOR'S USE OF ARCHITECT'S CAD FILES

- A. General: At Contractor's written request, copies of Architect's CAD files will be provided to Contractor for Contractor's use in connection with Project, subject to the following conditions:
  - 1. Release of CADD information will be restricted to the following categories:
    - a. Architectural floor plans.
    - b. Site plan.
    - c. Reflected ceiling plans.
    - d. Exterior elevations.
    - e. Stair sections.
  - 2. The CADD database will contain only the background information; the sheet numbers, sheet titles, room names and numbers, reference symbols, and other similar data will not be included.
  - 3. The CADD database will be generated on PC hardware with Autodesk AutoCAD software. Architect has the capability to develop CADD output to meet capabilities of all major platforms and major media types.
  - 4. When requesting CADD databases, specify the output form required.

## PART 3 PRODUCTS

### 3.1 ACTION SUBMITTALS

- A. General: Prepare and submit to Owner, Action Submittals required by individual Specification Sections.

- B. Electronic Submittals: Identify and incorporate information in each electronic submittal file as follows:
1. Assemble complete submittal package into a single indexed file incorporating submittal requirements of a single Specification Section and transmittal form with links enabling navigation to each item.
  2. Name file with submittal number or other unique identifier, including revision identifier.
    - a. File name shall use project identifier and Specification Section number followed by a decimal point and then a sequential number (e.g., LNHS-061000.01). Resubmittals shall include an alphabetic suffix after another decimal point (e.g., LNHS-061000.01.A).
  3. Provide means for insertion to permanently record Contractor's review and approval markings and action taken by Owner.
  4. Transmittal Form for Electronic Submittals: Use electronic form acceptable to Owner, containing the following information:
    - a. Project name.
    - b. Date.
    - c. Name and address of Architect.
    - d. Name of Construction Manager.
    - e. Name of Contractor.
    - f. Name of firm or entity that prepared submittal.
    - g. Names of subcontractor, manufacturer, and supplier.
    - h. Category and type of submittal.
    - i. Submittal purpose and description.
    - j. Specification Section number and title.
    - k. Specification paragraph number or drawing designation and generic name for each of multiple items.
    - l. Drawing number and detail references, as appropriate.
    - m. Location(s) where product is to be installed, as appropriate.
    - n. Related physical samples submitted directly.
    - o. Indication of full or partial submittal.
    - p. Transmittal number, numbered consecutively.
    - q. Submittal and transmittal distribution record.
    - r. Other necessary identification.
    - s. Remarks.
  5. Metadata: Include the following information as keywords in the electronic submittal file metadata:
    - a. Project name.
    - b. Number and title of appropriate Specification Section.
    - c. Manufacturer name.
    - d. Product name.
- C. Product Data: Collect information into a single submittal for each element of construction and type of product or equipment.
1. If information must be specially prepared for submittal because standard printed data are not suitable for use, submit as Shop Drawings, not as Product Data.
  2. Mark each copy of each submittal to show which products and options are applicable.
  3. Include the following information, as applicable:
    - a. Manufacturer's written recommendations.
    - b. Manufacturer's product specifications.

- c. Manufacturer's installation instructions.
  - d. Manufacturer's catalog cuts.
  - e. Wiring diagrams showing factory-installed wiring.
  - f. Printed performance curves.
  - g. Operational range diagrams.
  - h. Compliance with specified referenced standards.
  - i. Testing by recognized testing agency.
4. Number of Copies: Submit to Owner, four (4) copies of Product Data, unless otherwise indicated. Owner will return two (2) copies. Mark up and retain one (1) returned copy as a Project Record Document.
- D. Shop Drawings: Prepare Project-specific information, drawn accurately to scale. Do not base Shop Drawings on reproductions of the Contract Documents or standard printed data, unless submittal of Architect's CAD Drawings is otherwise permitted.
1. Preparation: Fully illustrate requirements in the Contract Documents. Include the following information, as applicable:
    - a. Dimensions.
    - b. Identification of products.
    - c. Fabrication and installation drawings.
    - d. Roughing-in and setting diagrams.
    - e. Wiring diagrams showing field-installed wiring, including power, signal, and control wiring.
    - f. Shop-work manufacturing instructions.
    - g. Templates and patterns.
    - h. Schedules.
    - i. Notation of coordination requirements.
    - j. Notation of dimensions established by field measurement.
    - k. Relationship to adjoining construction clearly indicated.
    - l. Seal and signature of professional engineer if specified.
    - m. Wiring Diagrams: Differentiate between manufacturer-installed and field-installed wiring.
  2. Sheet Size: Except for templates, patterns and similar full-size drawings, submit to Owner, Shop Drawings on sheets at least 8-1/2 by 11 inches but no larger than 36 by 48 inches.
  3. Number of Copies: Submit to Owner, a minimum of three (3) opaque (bond) copies of each submittal. Submit additional copies as required for each consultant. Owner will return two (2) copies. At the sole discretion of the Owner electronic copies may be acceptable.
- E. Samples: Submit to Owner, Samples for review of kind, color, pattern, and texture for a check of these characteristics with other elements and for a comparison of these characteristics between submittal and actual component as delivered and installed.
1. Transmit Samples that contain multiple, related components such as accessories together in one submittal package.
  2. Identification: Attach label on unexposed side of Samples that includes the following:
    - a. Generic description of Sample.
    - b. Product name and name of manufacturer.
    - c. Sample source.
    - d. Number and title of appropriate Specification Section.

3. Disposition: Maintain sets of approved Samples at Project site, available for quality control comparisons throughout the course of construction activity. Sample sets may be used to determine final acceptance of construction associated with each set.
4. Samples for Initial Selection: Submit manufacturer's color charts consisting of units or sections of units showing the full range of colors, textures and patterns available.
  - a. Number of Samples: Submit one (1) full set of available choices where color, pattern, texture or similar characteristics are required to be selected from manufacturer's product line. Owner will return submittal with options selected.
5. Samples for Verification: Submit full-size units or Samples of size indicated, prepared from same material to be used for the Work, cured and finished in manner specified, and physically identical with material or product proposed for use, and that show full range of color and texture variations expected. Samples include, but are not limited to, the following: partial sections of manufactured or fabricated components; small cuts or containers of materials; complete units of repetitively used materials; swatches showing color, texture and pattern; color range sets; and components used for independent testing and inspection.
  - a. Number of Samples: Submit three (3) sets of Samples. Owner will retain two (2) Sample sets; remainder will be returned.
- F. Product Schedule or List: As required in individual Specification Sections, prepare a written summary indicating types of products required for the Work and their intended location.
  1. Number of Copies: Submit a minimum of three (3) copies of product schedule or list, unless otherwise indicated. Submit additional copies for each consultant required to review the submittal. Owner will return two (2) copies.
- G. Submittals Schedule: Comply with requirements specified in the General Conditions of the Contract and Owner-Contractor Contract.
- H. Application for Payment: Comply with requirements specified in the Owner-Contractor Contract.
- I. Schedule of Values: Comply with requirements specified in the Owner-Contractor Contract. If needed, combine subcontract list in paragraph below with product list above. Subcontract list is required by General Conditions to be submitted as soon as practical after award of the Contract.
- J. Subcontract List: Prepare a written summary identifying individuals or firms proposed for each portion of the Work, including those who are to furnish products or equipment fabricated to a special design.
  1. Number of Copies: Submit electronically to Owner, one (1) copy of subcontractor list, unless otherwise indicated.

### 3.2 INFORMATIONAL SUBMITTALS

- A. General: Prepare and submit Informational Submittals required by other Specification Sections.

1. Number of Copies: Submit to Owner, two (2) copies of each submittal, unless otherwise indicated. Owner will not return copies.
  2. Certificates and Certifications: Provide a notarized statement that includes signature of entity responsible for preparing certification. Certificates and certifications shall be signed by an officer or other individual authorized to sign documents on behalf of that entity.
  3. Test and Inspection Reports: Comply with requirements specified in Division 01 40 Section "Quality Requirements."
- B. Coordination Drawings: Comply with requirements specified in Division 01 31 00 Section "Project Management and Coordination."
- C. Contractor's Final Project Schedule: Comply with requirements specified in the General Conditions of the Contract, and Owner-Contractor Contract.
- D. Qualification Data: Prepare written information that demonstrates capabilities and experience of firm or person. Include lists of completed projects with project names and addresses, names and addresses of architects and Owners, and other information specified.
- E. Welding Certificates: Prepare written certification that welding procedures and personnel comply with requirements in the Contract Documents. Submit record of Welding Procedure Specification (WPS) and Procedure Qualification Record (PQR) on AWS forms. Include names of firms and personnel certified.
- F. Installer Certificates: Prepare written statements on manufacturer's letterhead certifying that Installer complies with requirements in the Contract Documents and, where required, is authorized by manufacturer for this specific Project.
- G. Manufacturer Certificates: Prepare written statements on manufacturer's letterhead certifying that manufacturer complies with requirements in the Contract Documents. Include evidence of manufacturing experience where required.
- H. Product Certificates: Prepare written statements on manufacturer's letterhead certifying that product complies with requirements in the Contract Documents.
- I. Material Certificates: Prepare written statements on manufacturer's letterhead certifying that material complies with requirements in the Contract Documents.
- J. Material Test Reports: Prepare reports written by a qualified testing agency, on testing agency's standard form, indicating and interpreting test results of material for compliance with requirements in the Contract Documents.
- K. Product Test Reports: Prepare written reports indicating current product produced by manufacturer complies with requirements in the Contract Documents. Base reports on evaluation of tests performed by manufacturer and witnessed by a qualified testing agency, or on comprehensive tests performed by a qualified testing agency.
- L. Research/Evaluation Reports: Prepare written evidence, from a model code organization acceptable to authorities having jurisdiction, that product complies with building code in effect for Project.

- M. Pre-construction Test Reports: Prepare reports written by a qualified testing agency, on testing agency's standard form, indicating and interpreting results of tests performed before installation of product, for compliance with performance requirements in the Contract Documents.
- N. Compatibility Test Reports: Prepare reports written by a qualified testing agency, on testing agency's standard form, indicating and interpreting results of compatibility tests performed before installation of product. Include written recommendations for primers and substrate preparation needed for adhesion.
- O. Field Test Reports: Prepare reports written by a qualified testing agency, on testing agency's standard form, indicating and interpreting results of field tests performed either during installation of product or after product is installed in its final location, for compliance with requirements in the Contract Documents.
- P. Maintenance Data: Prepare written and graphic instructions and procedures for operation and normal maintenance of products and equipment. Comply with requirements specified in Division 01 78 23 Section "Operation and Maintenance Data."
- Q. Design Data: Prepare written and graphic information, including, but not limited to, performance and design criteria, list of applicable codes and regulations, and calculations. Include list of assumptions and other performance and design criteria and a summary of loads. Include load diagrams if applicable. Provide name and version of software, if any, used for calculations. Include page numbers.
- R. Manufacturer's Instructions: Prepare written or published information that documents manufacturer's recommendations, guidelines, and procedures for installing or operating a product or equipment. Include name of product and name, address and telephone number of manufacturer.
- S. Manufacturer's Field Reports: Prepare written information documenting factory-authorized service representative's tests and inspections. Include the following, as applicable:
1. Statement on condition of substrates and their acceptability for installation of product.
  2. Summary of installation procedures being followed, whether they comply with requirements and, if not, what corrective action was taken.
  3. Results of operational and other tests and a statement of whether observed performance complies with requirements.
- T. Insurance Certificates and Bonds: Prepare written information indicating current status of insurance or bonding coverage. Include name of entity covered by insurance or bond, limits of coverage, amounts of deductibles, if any, and term of the coverage.
- U. Material Safety Data Sheets (MSDSs): Submit information directly to Owner.
1. Architect will not review submittals that include MSDSs and will return them for resubmittal.

### 3.3 DELEGATED DESIGN

- A. Performance and Design Criteria: Where professional design services or certifications by a design professional are specifically required of Contractor by the Contract Documents, provide products and systems complying with specific performance and design criteria indicated.
  - 1. If criteria indicated are not sufficient to perform services or certification required, submit a written request for additional information to Owner.
- B. Delegated-Design Submittal: In addition to Shop Drawings, Product Data, and other required submittals, electronically submit three (3) copies of a statement, signed and sealed by the responsible design professional, for each product and system specifically assigned to Contractor to be designed or certified by a design professional.
  - 1. Indicate that products and systems comply with performance and design criteria in the Contract Documents. Include list of codes, loads, and other factors used in performing these services.
  - 2. If submittal has a wet stamp, then send three (3) hard copies, with the wet stamp to Owner for approval. Owner will return one (1) copy to Contractor.

## PART 4 EXECUTION

### 4.1 CONTRACTOR'S REVIEW

- A. Review each submittal and check for coordination with other Work of the Contract and for compliance with the Contract Documents. Note corrections and field dimensions.

### 4.2 OWNER'S ACTION

- A. Action Submittals: Owner will review each submittal, make marks to indicate corrections or modifications required, and return it. Owner will stamp each submittal with an action stamp and will mark stamp appropriately to indicate action taken.
- B. Informational Submittals: Owner will review each submittal and will not return it, or will return it if it does not comply with requirements. Owner will forward each submittal to appropriate party.
- C. Partial submittals are not acceptable, will be considered nonresponsive, and will be returned without review.
- D. Submittals not required by the Contract Documents may not be reviewed and may be discarded.

**END OF SECTION 01 3300**

## SECTION 01 4000 QUALITY REQUIREMENTS

### PART 1 GENERAL

#### 1.1 RELATED DOCUMENTS

- A. Drawings and general provisions of the Contract, including General and Supplementary Conditions and other Division 01 Specification Sections, apply to this Section.

#### 1.2 SUMMARY

- A. This Section includes administrative and procedural requirements for quality assurance and quality control.
- B. Testing and inspecting services are required to verify compliance with requirements specified or indicated. These services do not relieve Contractor of responsibility for compliance with the Contract Document requirements.
  - 1. Specified tests, inspections and related actions do not limit Contractor's other quality assurance and quality-control procedures that facilitate compliance with the Contract Document requirements.
  - 2. Requirements for Contractor to provide quality-assurance and quality-control services required by Architect, Owner, or authorities having jurisdiction are not limited by provisions of this Section.
- C. See Divisions 02 through 33 Sections for specific test and inspection requirements, if applicable. Not all Divisions will be used.

#### 1.3 DEFINITIONS

- A. Quality-Assurance Services: Activities, actions and procedures performed before and during execution of the Work to guard against defects and deficiencies and substantiate that proposed construction will comply with requirements.
- B. Quality-Control Services: Tests, inspections, procedures and related actions during and after execution of the Work to evaluate that actual products incorporated into the Work and completed construction comply with requirements. Services do not include contract enforcement activities performed by Owner.
- C. Mockups: Full-size, physical assemblies that are constructed on-site. Mockups are used to verify selections made under sample submittals, to demonstrate aesthetic effects and, where indicated, qualities of materials and execution, and to review construction, coordination, testing or operation; they are not Samples. Approved mockups establish the standard by which the Work will be judged.
- D. Pre-construction Testing: Tests and inspections that are performed specifically for the Project before products and materials are incorporated into the Work to verify performance or compliance with specified criteria.

- E. Product Testing: Tests and inspections that are performed by an NRTL, an NVLAP, or a testing agency qualified to conduct product testing and acceptable to authorities having jurisdiction, to establish product performance and compliance with industry standards.
- F. Source Quality-Control Testing: Tests and inspections that are performed at the source, i.e., plant, mill, factory or shop.
- G. Field Quality-Control Testing: Tests and inspections that are performed on-site for installation of the Work and for completed Work.
- H. Testing Agency: An entity engaged to perform specific tests, inspections or both. Testing laboratory shall mean the same as testing agency.
- I. Installer/Applicator/Erector: Contractor or another entity engaged by Contractor as an employee, Subcontractor, or Lower Tier Subcontractor, to perform a particular construction operation, including installation, erection, application and similar operations.
  - 1. Using a term such as "carpentry" does not imply that certain construction activities must be performed by accredited or unionized individuals of a corresponding generic name, such as "carpenter." It also does not imply that requirements specified apply exclusively to tradespeople of the corresponding generic name.
- J. Experienced: When used with an entity, "experienced" means having successfully completed a minimum of two (2) previous projects similar in size and scope to this Project; being familiar with special requirements indicated; and having complied with requirements of authorities having jurisdiction.

#### 1.4 CONFLICTING REQUIREMENTS

- A. General: If compliance with two (2) or more standards is specified and the standards establish different or conflicting requirements for minimum quantities or quality levels, comply with the most stringent requirement. Refer uncertainties and requirements that are different, but apparently equal, to Owner for a decision before proceeding.
- B. Minimum Quantity or Quality Levels: The quantity or quality level shown or specified shall be the minimum provided or performed. The actual installation may comply exactly with the minimum quantity or quality specified, or it may exceed the minimum within reasonable limits. To comply with these requirements, indicated numeric values are minimum or maximum, as appropriate, for the context of requirements. Refer uncertainties to Owner for a decision before proceeding.

#### 1.5 TESTING SUBMITTALS

- A. Qualification Data: For testing agencies, as prescribed by Contract, but not provided by Owner shall demonstrate their capabilities and experience. Include proof of qualifications in the form of a recent report on the inspection of the testing agency by a recognized authority.
- B. Reports: Prepare and electronically submit to the Owner certified written reports that include the following:
  - 1. Date of issue.

2. Project title and number.
  3. Name, address and telephone number of testing agency.
  4. Dates and locations of samples and tests or inspections.
  5. Names of individuals making tests and inspections.
  6. Description of the Work and test and inspection method.
  7. Identification of product and Specification Section.
  8. Complete test or inspection data.
  9. Test and inspection results and an interpretation of test results.
  10. Record of temperature and weather conditions at time of sample taking and testing and inspecting.
  11. Comments or professional opinion on whether tested or inspected Work complies with the Contract Document requirements.
  12. Name and signature of laboratory inspector.
  13. Recommendations on re-testing and re-inspecting.
- C. Permits, Licenses and Certificates: For Owner's records, submit copies of permits, licenses, certifications, inspection reports, releases, jurisdictional settlements, notices, receipts for fee payments, judgments, correspondence, records and similar documents, established for compliance with standards and regulations bearing on performance of the Work.

#### 1.6 QUALITY ASSURANCE

- A. General: Qualifications paragraphs in this Article establish the minimum qualification levels required; individual Specification Sections specify additional requirements.
- B. Installer Qualifications: A firm or individual experienced in installing, erecting, or assembling work similar in material, design and extent to that indicated for this Project, whose work has resulted in construction with a record of successful in-service performance.
- C. Manufacturer Qualifications: A firm experienced in manufacturing products or systems similar to those indicated for this Project and with a record of successful in-service performance, as well as sufficient production capacity to produce required units.
- D. Fabricator Qualifications: A firm experienced in producing products similar to those indicated for this Project and with a record of successful in-service performance, as well as sufficient production capacity to produce required units.
- E. Professional Engineer Qualifications: A professional engineer who is legally qualified to practice in jurisdiction where Project is located and who is experienced in providing engineering services of the kind indicated. Engineering services are defined as those performed for installations of the system, assembly or product that is similar to those indicated for this Project in material, design and extent.
- F. Specialists: Certain sections of the Specifications require that specific construction activities shall be performed by entities who are recognized experts in those operations. Specialists shall satisfy qualification requirements indicated and shall be engaged for the activities indicated.
1. Requirement for specialists shall not supersede building codes and regulations governing the Work.

- G. Testing Agency Qualifications: An NRTL, an NVLAP, or an independent agency with the experience and capability to conduct testing and inspecting indicated, as documented according to ASTM E 548; and with additional qualifications specified in individual Sections; and where required by authorities having jurisdiction, that is acceptable to authorities.
1. NRTL: A nationally recognized testing laboratory according to 29 CFR 1910.7.
  2. NVLAP: A testing agency accredited according to NIST's National Voluntary Laboratory Accreditation Program.
- H. Factory-Authorized Service Representative Qualifications: An authorized representative of manufacturer who is trained and approved by manufacturer to inspect installation of manufacturer's products that are similar in material, design and extent to those indicated for this Project.
- I. Mockups: Before installing portions of the Work requiring mockups, build mockups for each form of construction and finish required to comply with the following requirements, using materials indicated for the completed Work:
1. Build mockups in location and of size indicated or, if not indicated, as directed by Owner.
  2. Notify Owner seven (7) calendar days in advance of dates and times when mockups will be constructed.
  3. Demonstrate the proposed range of aesthetic effects and workmanship.
  4. Obtain Owner's approval of mockups before starting work, fabrication or construction.
  5. Maintain mockups during construction in an undisturbed condition as a standard for judging the completed Work.
  6. Demolish and remove mockups when directed, unless otherwise indicated.
- J. Laboratory Mockups: Comply with requirements of pre-construction testing and those specified in individual Sections in Divisions 02 through 33.

## 1.7 QUALITY CONTROL

- A. Owner Responsibilities: Where quality-control services are indicated as Owner's responsibility, Owner will engage a qualified testing agency to perform these services.
1. Owner will furnish Contractor with names, addresses and telephone numbers of testing agencies engaged and a description of types of testing and inspecting they are engaged to perform.
  2. Costs for retesting and re-inspecting construction that replaces or is necessitated by work that failed to comply with the Contract Documents will be charged to Contractor.
- B. Tests and inspections not explicitly assigned to Owner are Contractor's responsibility. Unless otherwise indicated, provide quality-control services specified and those required by authorities having jurisdiction. Perform quality-control services required of Contractor by authorities having jurisdiction, whether specified or not.
1. Where services are indicated as Contractor's responsibility, engage a qualified testing agency to perform these quality-control services.
    - a. Contractor shall not employ same entity engaged by Owner, unless agreed to in writing by Owner.

2. Notify testing agencies at least twenty-four 24 hours in advance of time when Work that requires testing or inspecting will be performed.
  3. Where quality-control services are indicated as Contractor's responsibility, electronically submit a certified written report, in duplicate, of each quality-control service to the Owner.
  4. Testing and inspecting requested by Contractor and not required by the Contract Documents are Contractor's responsibility.
  5. Submit additional copies of each written report directly to authorities having jurisdiction, when they so direct.
- C. Manufacturer's Field Services: Where indicated, engage a factory-authorized service representative to inspect field-assembled components and equipment installation, including service connections. Report results in writing as specified in Division 01 33 00 Section "Submittal Procedures."
- D. Re-testing/Re-inspecting: Regardless of whether original tests or inspections were Contractor's responsibility, provide quality-control services, including re-testing and re-inspecting, for construction that replaced Work that failed to comply with the Contract Documents.
- E. Testing Agency Responsibilities: Cooperate with Owner and Contractor in performance of duties. Provide qualified personnel to perform required tests and inspections.
1. Notify Owner and Contractor promptly of irregularities or deficiencies observed in the Work during performance of its services.
  2. Determine the location from which test samples will be taken and in which on-site tests will be conducted.
  3. Conduct and interpret tests and inspections and state in each report whether tested and inspected work complies with or deviates from requirements.
  4. Electronically submit to the Owner a certified written report, in duplicate, of each test, inspection and similar quality-control service through Contractor.
  5. Do not release, revoke, alter, or increase the Contract Document requirements or approve or accept any portion of the Work.
  6. Do not perform any duties of Contractor.
- F. Associated Services: Cooperate with agencies performing required tests, inspections and similar quality-control services, and provide reasonable auxiliary services as requested. Notify agency sufficiently in advance of operations to permit assignment of personnel. Provide the following:
1. Access to the Work.
  2. Incidental labor and facilities necessary to facilitate tests and inspections.
  3. Adequate quantities of representative samples of materials that require testing and inspecting. Assist agency in obtaining samples.
  4. Facilities for storage and field curing of test samples.
  5. Delivery of samples to testing agencies.
  6. Preliminary design mix proposed for use for material mixes that require control by testing agency.
  7. Security and protection for samples and for testing and inspecting equipment at Project site.

- G. Coordination: Coordinate sequence of activities to accommodate required quality-assurance and quality-control services with a minimum of delay and to avoid necessity of removing and replacing construction to accommodate testing and inspecting.
  - 1. Schedule times for tests, inspections, obtaining samples and similar activities.

## 1.8 SPECIAL TESTS AND INSPECTIONS

- A. Special Tests and Inspections: Owner will engage a qualified special inspector to conduct special tests and inspections required by authorities having jurisdiction as the responsibility of Owner, and as follows:
  - 1. Verifying that manufacturer maintains detailed fabrication and quality-control procedures and reviewing the completeness and adequacy of those procedures to perform the Work.
  - 2. Notifying Owner and Contractor promptly of irregularities and deficiencies observed in the Work during performance of its services.
  - 3. Submitting a certified written report of each test, inspection, and similar quality-control service to Owner with copy to Contractor and to authorities having jurisdiction.
  - 4. Electronically submitting to the Owner a final report of special tests and inspections, which includes a list of unresolved deficiencies, at Substantial Completion.
  - 5. Interpreting tests and inspections and stating in each report whether tested and inspected work complies with or deviates from the Contract Documents.
  - 6. Re-testing and re-inspecting corrected work.

## PART 2 PRODUCTS (Not Used)

## PART 3 EXECUTION

### 3.1 REPAIR AND PROTECTION

- A. General: On completion of testing, inspecting, sample taking and similar services, repair damaged construction and restore substrates and finishes.
  - 1. Provide materials and comply with installation requirements specified in other Specification Sections. Restore patched areas and extend restoration into adjoining areas with durable seams that are as invisible as possible.
  - 2. Comply with the Contract Document requirements for Division 01 73 29 Section "Cutting and Patching."
- B. Protect construction exposed by or for quality-control service activities.
- C. Repair and protection are Contractor's responsibility, regardless of the assignment of responsibility for quality-control services.

**END OF SECTION 01 4000**

**SECTION 01 5000  
TEMPORARY FACILITIES AND CONTROLS**

PART 1 GENERAL

1.1 RELATED DOCUMENTS

- A. Drawings and general provisions of the Contract, including General and Supplementary Conditions and other Division 01 73 00 Specification Sections, apply to this Section.

1.2 SUMMARY

- A. This Section includes requirements for temporary utilities, support facilities, and security and protection facilities.
- B. See Division 01 Section "Execution" for progress cleaning requirements.
- C. See Divisions 02 through 33 Sections for temporary heat, ventilation, and humidity requirements for products in those Sections. Not all Sections will be used

1.3 DEFINITIONS

- A. Permanent Enclosure: As determined by Architect, permanent or temporary roofing is complete, insulated and weathertight; exterior walls are insulated and weathertight; and all openings are closed with permanent construction or substantial temporary closures.

1.4 USE CHARGES

- A. General: Cost or use charges for temporary facilities shall be included in the Contract Sum. Allow other entities to use temporary services and facilities without cost, including, but not limited to, Owner's construction forces, Architect, testing agencies and authorities having jurisdiction.
- B. Water Service from Existing System: Water from Owner's existing water system is available for use with approval of Owner's Representative. Provide connections and extensions of services as required for construction operations. Contractor must notify Owner forty-eight (48) hours before use of water service.
- C. Electric Power Service from Existing System: Contractor is responsible for supplying power service and distribution as required for construction operations, unless other arrangements are made with approval of Owner's Representative.

1.5 QUALITY ASSURANCE

- A. Electric Service: Comply with NECA, NEMA, and UL standards and regulations for temporary electric service. Install service to comply with NFPA 70.

1.6 PROJECT CONDITIONS

- A. Temporary Use of Existing Permanent Facilities: Contractor shall assume responsibility for operation, maintenance and protection of each existing permanent service during its use as a construction facility before Owner's acceptance, regardless of previously assigned responsibilities.
- B. Conditions of Use: The following conditions apply to use of temporary services and existing facilities by all parties engaged in the Work:
  - 1. Keep temporary services and existing facilities clean and neat.
  - 2. Relocate temporary services as required by progress of the Work.
  - 3. Provide temporary keys and lock cores throughout duration of Contractor's occupancy of Owner's space. Contractor to provide Owner's Representative with temporary construction keys matching construction cores installed for access.
    - a. When Contractor is given keys to KCHA property, Contractor will claim responsibility for the keys by signing for keys acquired. If Contractor loses keys, Contractor is responsible for rekeying all locks associated with lost key. Contractor is responsible for returning keys back to Owner's Representative when Work is completed.

PART 2 PRODUCTS

2.1 TEMPORARY FACILITIES

- A. Field Offices, General: Prefabricated or mobile units with serviceable finishes, temperature controls and foundations adequate for normal loading.
- B. Storage and Fabrication Sheds: Provide sheds sized, furnished and equipped to accommodate materials and equipment for construction operations.
- C. Contractor is responsible for security of Temporary Facilities.

2.2 EQUIPMENT

- A. Fire Extinguishers: Portable, UL rated; with class and extinguishing agent as required by locations and classes of fire exposures.
- B. HVAC Equipment: Unless Owner authorizes use of permanent HVAC system, provide vented, self-contained, liquid-propane-gas or fuel-oil heaters with individual space thermostatic control.
  - 1. Use of gasoline-burning space heaters, open-flame heaters or salamander-type heating units is prohibited.
  - 2. Heating Units: Listed and labeled for type of fuel being consumed, by a testing agency acceptable to authorities having jurisdiction, and marked for intended use.
  - 3. Permanent HVAC System: If Owner authorizes use of permanent HVAC system for temporary use during construction, provide filter with MERV of 13 at each return air grille in system and remove and replace at end of construction.
- C. Self-Contained Toilet Units: Single-occupant units of chemical, aerated re-circulation, or combustion type; vented; fully-enclosed with a glass-fiber-reinforced polyester shell or similar nonabsorbent material.

- D. Drinking-Water Fixtures: Containerized, tap-dispenser, bottled-water, drinking-water units, including paper cup supply.
  - 1. Where power is accessible, provide electric water coolers to maintain dispensed water temperature at 45 to 55 degrees F.
- E. Electrical Outlets: Properly configured, NEMA-polarized outlets to prevent insertion of 110-to-120-V plugs into higher-voltage outlets; equipped with ground-fault circuit interrupters, reset button and pilot light.
- F. Power Distribution System Circuits: Where permitted, and overhead and exposed for surveillance, wiring circuits, not exceeding 125-V AC, 20-A rating, and lighting circuits may be nonmetallic sheathed cable.

### PART 3 EXECUTION

#### 3.1 INSTALLATION, GENERAL

- A. With Owner's approval, locate facilities where they will serve Project adequately and result in minimum interference with performance of the Work. Relocate and modify facilities as required by progress of the Work.
- B. Provide each facility ready for use when needed to avoid delay. Do not remove until facilities are no longer needed or are replaced by authorized use of completed permanent facilities.

#### 3.2 TEMPORARY UTILITY INSTALLATION

- A. General: Install temporary service or connect to existing service.
  - 1. Arrange with utility company, Owner, and existing users for time when service can be interrupted, if necessary, to make connections for temporary services. Provide Owner with seventy-two (72) hour notice if disturbance is to occur to site staff or residents.
- B. Water Service: Connect to Owner's existing water service facilities. Clean and maintain water service facilities in a condition acceptable to Owner. At Substantial Completion, restore these facilities to condition existing before initial use.
- C. Sanitary Facilities: Provide temporary toilets, wash facilities and drinking water for use by construction personnel. Comply with requirements of authorities having jurisdiction for type, number, location, operation and maintenance of fixtures and facilities.
  - 1. Toilets: Use of Owner's existing toilet facilities will be permitted with Owner's approval, as long as facilities are cleaned and maintained daily. At Substantial Completion, restore these facilities to condition existing before initial use.
- D. Heating and Cooling: Provide temporary heating and cooling required by construction activities for curing or drying of completed installations or for protecting installed construction from adverse effects of low temperatures or high humidity. Select equipment that will not have a harmful effect on completed installations or elements being installed.

1. Maintain a minimum temperature of 50 degrees F in permanently enclosed portions of building for normal construction activities, and 65 degrees F for finishing activities and areas where finished Work has been installed.
  2. Isolation of Work Areas in Occupied Facilities: Prevent dust, fumes and odors from entering occupied areas.
- E. Ventilation and Humidity Control: Provide temporary ventilation required by construction activities for curing or drying of completed installations or for protecting installed construction from adverse effects of high humidity. Select equipment that will not have a harmful effect on completed installations or elements being installed. Coordinate ventilation requirements to produce ambient condition required and minimize energy consumption.
- F. Electric Power Service: Provide electric power service and distribution system of sufficient size, capacity, and power characteristics required for construction operations.
1. Connect temporary service to Owner's existing power source, as directed by Owner after receiving approval by Owner's Representative.
- G. Lighting: Provide temporary lighting with local switching that provides adequate illumination for construction operations, observations, inspections and traffic conditions.
1. Install and operate temporary lighting that fulfills security and protection requirements without operating entire system.

### 3.3 SUPPORT FACILITIES INSTALLATION

- A. Waste Disposal Facilities: Provide waste-collection containers in sizes adequate to handle waste from construction operations. Comply with requirements of authorities having jurisdiction. Comply with Division 01 73 00 Section "Execution" for progress cleaning requirements. Contractor shall not use Owner's waste receptacles for any disposal.
- B. Parking: Use designated areas of Owner's existing parking areas for construction personnel upon Owner's approval.

### 3.4 SECURITY AND PROTECTION FACILITIES INSTALLATION

- A. Protection of Existing Facilities: Protect existing vegetation, equipment, structures, utilities and other improvements at Project site and on adjacent properties, except those indicated to be removed or altered. Repair damage to existing facilities.
- B. Environmental Protection: Provide protection, operate temporary facilities and conduct construction in ways and by methods that comply with environmental regulations and that minimize possible air, waterway and subsoil contamination or pollution or other undesirable effects.
- C. Security Enclosure and Lockup: Install substantial temporary enclosure around partially completed areas of construction. Provide lockable entrances to prevent unauthorized entrance, vandalism, theft and similar violations of security.
- D. Barricades, Warning Signs, and Lights: Comply with Owner's instructions for erecting structurally adequate barricades, including warning signs and lighting.

- E. Temporary Egress: Maintain temporary egress from existing occupied facilities as indicated and as required by Owner.
- F. Temporary Enclosures: Provide temporary enclosures for protection of construction, in progress and completed, from exposure, foul weather, other construction operations and similar activities. Provide temporary weathertight enclosure for building exterior.
  - 1. Where heating or cooling is needed and permanent enclosure is not complete, insulate temporary enclosures.
- G. Temporary Partitions: Provide floor-to-ceiling dustproof partitions to limit dust and dirt migration and to separate areas occupied by tenants from fumes and noise.
  - 1. Construct dustproof partitions with two (2) layers of 6-mil polyethylene sheet on each side. Overlap and tape full length of joints.
  - 2. Where fire-resistance-rated temporary partitions are indicated or are required by authorities having jurisdiction, construct partitions according to the rated assemblies.
  - 3. Seal joints and perimeter.
  - 4. Protect air-handling equipment.
  - 5. Provide walk-off mats at each entrance through temporary partition.
  - 6. Dust Control/Air handlers
- H. Temporary Fire Protection: Install and maintain temporary fire-protection facilities of types needed to protect against reasonably predictable and controllable fire losses. Comply with NFPA 241.
  - 1. Prohibit smoking on Owner's property.
  - 2. Supervise welding operations, combustion-type temporary heating units and similar sources of fire ignition according to requirements of authorities having jurisdiction.

### 3.5 OPERATION, TERMINATION AND REMOVAL

- A. Supervision: Enforce strict discipline in use of temporary facilities. To minimize waste and abuse, limit availability of temporary facilities to essential and intended uses.
- B. Maintenance: Maintain facilities in good operating condition until removal.
  - 1. Maintain operation of temporary enclosures, heating, cooling, humidity control, ventilation and similar facilities on a twenty-four (24) hour basis where required to achieve indicated results and to avoid possibility of damage.
- C. Temporary Facility Changeover: Do not change over from using temporary security and protection facilities to permanent facilities until Substantial Completion.
- D. Termination and Removal: Remove each temporary facility when need for its service has ended, when it has been replaced by authorized use of a permanent facility or no later than Substantial Completion. Complete or, if necessary, restore permanent construction that may have been delayed because of interference with temporary facility. Repair damaged Work, clean exposed surfaces and replace construction that cannot be satisfactorily repaired.
  - 1. Materials and facilities that constitute temporary facilities are property of Contractor. Owner reserves right to take possession of Project identification signs.

2. At Substantial Completion, clean and renovate permanent facilities used during construction period. Comply with final cleaning requirements specified in Division 01 77 00 Section "Closeout Procedures."

END OF SECTION 01 5000

## SECTION 01 6000 PRODUCT REQUIREMENTS

### PART 1 GENERAL

#### 1.1 RELATED DOCUMENTS

- A. Drawings and general provisions of the Contract, including General and Supplementary Conditions and other Division 01 Specification Sections, apply to this Section.

#### 1.2 SUMMARY

- A. This Section includes administrative and procedural requirements for selection of products for use in Project; product delivery, storage and handling; manufacturers' standard warranties on products; special warranties; product substitutions; and comparable products.
- B. See Division 01 77 00 Section "Closeout Procedures" for submitting warranties for Contract closeout.
- C. See Divisions 02 through 33 Sections for specific requirements for warranties on products and installations specified to be warranted. Not all Sections will be used.

#### 1.3 DEFINITIONS

- A. Products: Items purchased for incorporating into the Work, whether purchased for Project or taken from previously purchased stock. The term "product" includes the terms "material," "equipment," "system," and terms of similar intent.
  - 1. Named Products: Items identified by manufacturer's product name, including make or model number or other designation shown or listed in manufacturer's published product literature that is current as of date of the Contract Documents.
  - 2. New Products: Items that have not previously been incorporated into another project or facility, except that products consisting of recycled-content materials are allowed, unless explicitly stated otherwise. Products salvaged or recycled from other projects are not considered new products.
  - 3. Comparable Product: Product that is demonstrated and approved through submittal process, or where indicated as a product substitution, to have the indicated qualities related to type, function, dimension, in-service performance, physical properties, appearance and other characteristics that equal or exceed those of specified product.
- B. Substitutions: Changes in products, materials, equipment and methods of construction from those required by the Contract Documents and proposed by Contractor.
- C. Basis-of-Design Product Specification: Where a specific manufacturer's product is named and accompanied by the words "basis of design," including make or model number or other designation, to establish the significant qualities related to type, function, dimension, in-service performance, physical properties, appearance and other characteristics for purposes of evaluating comparable products of other named manufacturers.

#### 1.4 SUBMITTALS

- A. Substitution Requests: Electronically submit three (3) copies of each request for consideration to the Owner. Identify product or fabrication or installation method to be replaced. Include Specification Section number and title and Drawing numbers and titles.
1. Documentation: Show compliance with requirements for substitutions and the following, as applicable:
    - a. Statement indicating why specified material or product cannot be provided.
    - b. Coordination information, including a list of changes or modifications needed to other parts of the Work and to construction performed by Owner and separate contractors, which will be necessary to accommodate proposed substitution.
    - c. Detailed comparison of significant qualities of proposed substitution with those of the Work specified. Significant qualities may include attributes such as performance, weight, size, durability, visual effect and specific features and requirements indicated.
    - d. Product Data, including drawings and descriptions of products and fabrication and installation procedures.
    - e. Samples, where applicable or requested.
    - f. List of similar installations for completed projects with project names and addresses and the names and addresses of Architects and Owners.
    - g. Material test reports from a qualified testing agency indicating and interpreting test results for compliance with requirements indicated.
    - h. Research/evaluation reports evidencing compliance with building code in effect for Project, from a model code organization acceptable to authorities having jurisdiction.
    - i. Detailed comparison of Contractor's Final Project Schedule using proposed substitution with products specified for the Work, including effect on the overall Contract Time. If specified product or method of construction cannot be provided within the Contract Time, include letter from manufacturer, on manufacturer's letterhead, stating lack of availability or delays in delivery.
    - j. Cost information, including a proposal of change, if any, in the Contract Sum.
    - k. Contractor's certification that proposed substitution complies with requirements in the Contract Documents and is appropriate for applications indicated.
    - l. Contractor's waiver of rights to additional payment or time that may subsequently become necessary because of failure of proposed substitution to produce indicated results.
  2. Owner's Action: If necessary, the Owner will request additional information or documentation for evaluation within five (5) calendar days of receipt of a request for substitution. Owner will notify Contractor of acceptance or rejection of proposed substitution within ten (10) calendar days of receipt of request, or five (5) calendar days of receipt of additional information or documentation, whichever is later.
    - a. Form of Acceptance: Signed and Approved Substitution Request Form.

- B. Basis-of-Design Product Specification Submittal: Comply with requirements in Division 01 Section "Submittal Procedures." Show compliance with requirements.

#### 1.5 QUALITY ASSURANCE

- A. Compatibility of Options: If Contractor is given option of selecting between two (2) or more products for use on Project, product selected shall be compatible with products previously selected, even if previously selected products were also options.

#### 1.6 PRODUCT DELIVERY, STORAGE, AND HANDLING

- A. Deliver, store and handle products using means and methods that will prevent damage, deterioration and loss, including theft. Comply with manufacturer's written instructions.

- B. Delivery and Handling:

1. Schedule delivery to minimize long-term storage at Project site and to prevent overcrowding of construction spaces.
2. Coordinate delivery with installation time to ensure minimum holding time for items that are flammable, hazardous, easily damaged or sensitive to deterioration, theft and other losses.
3. Deliver products to Project site in an undamaged condition in manufacturer's original sealed container or other packaging system, complete with labels and instructions for handling, storing, unpacking, protecting and installing.
4. Inspect products on delivery to ensure compliance with the Contract Documents and to ensure that products are undamaged and properly protected.

- C. Storage:

1. Store products to allow for inspection and measurement of quantity or counting of units.
2. Store materials in a manner that will not endanger Project structure.
3. Store products that are subject to damage by the elements, under cover in a weathertight enclosure above ground, with ventilation adequate to prevent condensation.
4. Store cementitious products and materials on elevated platforms.
5. Store foam plastic from exposure to sunlight, except to extent necessary for period of installation and concealment.
6. Comply with product manufacturer's written instructions for temperature, humidity, ventilation and weather-protection requirements for storage.
7. Protect stored products from damage and liquids from freezing.

#### 1.7 PRODUCT WARRANTIES

- A. Warranties specified in other Sections shall be in addition to, and run concurrent with, other warranties required by the Contract Documents. Manufacturer's disclaimers and limitations on product warranties do not relieve Contractor of obligations under requirements of the Contract Documents.

1. Manufacturer's Warranty: Pre-printed written warranty published by individual manufacturer for a particular product and specifically endorsed by manufacturer to Owner.

2. Special Warranty: Written warranty required by or incorporated into the Contract Documents, either to extend time limit provided by manufacturer's warranty or to provide more rights for Owner.
- B. Special Warranties: Prepare a written document that contains appropriate terms and identification, ready for execution. Electronically submit a draft for approval before final execution to the Owner.
1. Manufacturer's Standard Form: Modified to include Project-specific information and properly executed.
  2. Specified Form: When specified forms are included with the Specifications, prepare a written document using appropriate form properly executed.
  3. Refer to Divisions 2 through 33 Sections for specific content requirements and particular requirements for submitting special warranties. Not all Sections will be used.
- C. Submittal Time: Comply with requirements in Division 01 Section "Closeout Procedures."

## PART 2 PRODUCTS

### 2.1 PRODUCT SELECTION PROCEDURES

- A. General Product Requirements: Provide products that comply with the Contract Documents, that are undamaged and, unless otherwise indicated, that are new at time of installation.
1. Provide products complete with accessories, trim, finish, fasteners and other items needed for a complete installation and indicated use and effect.
  2. Standard Products: If available, and unless custom products or nonstandard options are specified, provide standard products of types that have been produced and used successfully in similar situations on other projects.
  3. Owner reserves the right to limit selection to products with warranties not in conflict with requirements of the Contract Documents.
  4. Where products are accompanied by the term "as selected," Owner will make selection.
  5. Where products are accompanied by the term "match sample," sample to be matched is Owner's.
  6. Descriptive, performance and reference standard requirements in the Specifications establish "salient characteristics" of products.
- B. Product Selection Procedures:
1. Products: Where Specifications include a list of names of both products and manufacturers, provide one (1) of the products listed or equal product that complies with requirements.
  2. Manufacturers: Where Specifications include a list of manufacturers' names, provide a product by one (1) of the manufacturers listed or equal manufacturer that complies with requirements.
  3. Available Products: Where Specifications include a list of names of both products and manufacturers, provide one (1) of the products listed, or a equal product. Comply with provisions in Part 2 "Product Substitutions" Article for consideration of an unnamed "or Equal" product.

4. Available Manufacturers: Where Specifications include a list of manufacturers, provide a product by one (1) of the manufacturers listed, or an unnamed manufacturer, that complies with requirements. Comply with provisions in Part 2 "Product Substitutions" Article for consideration of an unnamed manufacturer.
5. Product Options: Where Specifications indicate that sizes, profiles and dimensional requirements on Drawings are based on a specific product or system, provide the specified product or system. Comply with provisions in Part 2 "Product Substitutions" Article for consideration of an unnamed product or system.
6. Basis-of-Design Product: Where Specifications name a product and include a list of manufacturers, provide the specified product or a comparable product by one (1) of the other named manufacturers. Drawings and Specifications indicate sizes, profiles, dimensions and other characteristics that are based on the product named. Comply with provisions in Part 2 "Product Substitutions" Article for consideration of an unnamed product by the other named manufacturers.
7. Visual Matching Specification: Where Specifications require matching an established Sample, select a product that complies with requirements and matches Owner's sample. Owner's decision will be final on whether a proposed product matches.
  - a. If no product available within specified category matches and complies with other specified requirements, comply with provisions in Part 2 "Product Substitutions" Article for proposal of product.
8. Visual Selection Specification: Where Specifications include the phrase "as selected from manufacturer's colors, patterns and textures" or a similar phrase, select a product that complies with other specified requirements.
  - a. Standard Range: Where Specifications include the phrase "standard range of colors, patterns, textures" or similar phrase, Owner will select color, pattern, density or texture from manufacturer's product line that does not include premium items.
  - b. Full Range: Where Specifications include the phrase "full range of colors, patterns, textures" or similar phrase, Owner will select color, pattern, density or texture from manufacturer's product line that includes both standard and premium items.

## 2.2 PRODUCT SUBSTITUTIONS

- A. Timing: Owner will consider requests for substitutions if received within sixty (60) days after the Notice to Proceed. Requests received after that time may be considered or rejected at discretion of Owner. .
- B. Conditions: Owner will consider Contractor's request for substitution when the following conditions are satisfied. If the following conditions are not satisfied, Owner will return requests without action, except to record noncompliance with these requirements:
  1. Requested substitution offers Owner a substantial advantage in cost, time, energy conservation, or other considerations, after deducting additional responsibilities Owner must assume. Owner's additional responsibilities may include compensation to Architect for redesign and evaluation services, increased cost of other construction by Owner and similar considerations.
  2. Requested substitution does not require extensive revisions to the Contract Documents.

3. Requested substitution is consistent with the Contract Documents and will produce indicated results.
4. Substitution request is fully documented and properly submitted.
5. Requested substitution will not adversely affect Contractor's Final Project Schedule.
6. Requested substitution has received necessary approvals of authorities having jurisdiction.
7. Requested substitution is compatible with other portions of the Work.
8. Requested substitution has been coordinated with other portions of the Work.
9. Requested substitution provides specified warranty.

PART 3 EXECUTION (Not Used)

**END OF SECTION 01 6000**

**SECTION 01 7300  
EXECUTION**

PART 1 GENERAL

1.1 RELATED DOCUMENTS

- A. Drawings and general provisions of the Contract, including General and Supplementary Conditions and other Division 01 Specification Sections, apply to this Section.

1.2 SUMMARY

- A. This Section includes general procedural requirements governing execution of the Work including, but not limited to, the following:
  - 1. Construction layout.
  - 2. General installation of products.
  - 3. Progress cleaning.
  - 4. Starting and adjusting.
  - 5. Protection of installed construction.
  - 6. Correction of the Work.
- B. See Division 01 Section "Closeout Procedures" for submitting final property survey with Project Record Documents, recording of Owner-accepted deviations from indicated lines and levels, and final cleaning.

1.3 SUBMITTALS

- A. Not Applicable

PART 2 PRODUCTS (Not Used)

PART 3 EXECUTION

3.1 EXAMINATION

- A. Existing Conditions: The existence and location of site improvements, utilities and other construction indicated as existing are not guaranteed. Before beginning work, investigate and verify the existence and location of mechanical and electrical systems and other construction affecting the Work. Notify Owner of any discrepancies between plans and actual conditions on site.
  - 1. Before construction, verify the location and points of connection of utility services.
- B. Acceptance of Conditions: Examine substrates, areas and conditions, with Installer or Applicator and Owner present where indicated, for compliance with requirements for installation tolerances and other conditions affecting performance. Record observations.
  - 1. Verify compatibility with and suitability of substrates, including compatibility with existing finishes or primers.

2. Examine roughing-in for mechanical and electrical systems to verify actual locations of connections before equipment and fixture installation.
3. Examine walls, floors and roofs for suitable conditions where products and systems are to be installed.
4. Proceed with installation only after unsatisfactory conditions have been corrected and approved by Owner. Proceeding with the Work indicates acceptance of surfaces and conditions.

### 3.2 PREPARATION

- A. Field Measurements: Take field measurements as required to fit the Work properly. Recheck measurements before installing each product. Where portions of the Work are indicated to fit to other construction, verify dimensions of other construction by field measurements before fabrication. Coordinate fabrication schedule with construction progress to avoid delaying the Work.
- B. Space Requirements: Verify space requirements and dimensions of items shown diagrammatically on Drawings.
- C. Review of Contract Documents and Field Conditions: Immediately on discovery of the need for clarification of the Contract Documents, submit a request for information to Owner, per Section 01 3100.
  1. It is the Contractor's responsibility to coordinate between the various Contract Documents, including the Drawings and Specifications, with neither superseding the other. In the event of conflicts or discrepancies among the Contract Documents, it is the Contractor's responsibility to seek clarification.
  2. Where conflicts and/or omissions have not been brought to the attention of the Owner, it is understood that the Contractor has made provisions in the bid for the most costly material or methods.

### 3.3 CONSTRUCTION LAYOUT

- A. Verification: Before proceeding to lay out the Work, verify layout information shown on Drawings, in relation to the property survey and existing benchmarks. If discrepancies are discovered, notify Owner promptly.
- B. General: Engage experienced layout engineers to lay out the Work using accepted surveying practices.
  1. Establish dimensions within tolerances indicated. Do not scale Drawings to obtain required dimensions.
  2. Inform installers of lines and levels to which they must comply.
  3. Check the location, level and plumb, of every major element as the Work progresses.
  4. Notify Owner when deviations from required lines and levels exceed allowable tolerances.

### 3.4 FIELD ENGINEERING

- A. Reference Points: Locate existing permanent benchmarks, control points and similar reference points before beginning the Work. Preserve and protect permanent benchmarks and control points during construction operations.

### 3.5 INSTALLATION

- A. General: Locate the Work and components of the Work accurately, in correct alignment and elevation, as indicated.
  - 1. Make vertical work plumb and make horizontal work level.
  - 2. Where space is limited, install components to maximize space available for maintenance and ease of removal for replacement.
  - 3. Conceal pipes, ducts and wiring in finished areas unless otherwise indicated.
  - 4. Install materials in lengths that produce the minimum amount of joints.
- B. Comply with manufacturer's written instructions and recommendations for installing products in applications indicated.
- C. Install products at the time and under conditions that will ensure the best possible results. Maintain conditions required for product performance until Substantial Completion.
- D. Conduct construction operations so no part of the Work is subjected to damaging operations or loading in excess of that expected during normal conditions of occupancy.
- E. Tools and Equipment: Do not use tools or equipment that produces harmful noise and dust levels. Refer to Dust Control in the Scope of Work.
- F. Templates: Obtain and distribute to the parties involved templates for work specified to be factory prepared and field installed. Check Shop Drawings of other work to confirm that adequate provisions are made for locating and installing products to comply with indicated requirements.
- G. Attachments: Provide blocking and attachment plates, anchors and fasteners of adequate size and number to securely anchor each component in place, accurately located and aligned with other portions of the Work. Where size and type of attachments are not indicated, verify size and type required for load conditions.
  - 1. Mounting Heights: Where mounting heights are not indicated, mount components at heights directed by Owner.
  - 2. Allow for building movement, including thermal expansion and contraction.
  - 3. Coordinate installation of anchorages. Furnish setting drawings, templates and directions for installing anchorages, including sleeves, concrete inserts, anchor bolts, and items with integral anchors, that are to be embedded in concrete or masonry. Deliver such items to Project site in time for installation.
- H. Joints: Make joints of uniform width. Where joint locations in exposed work are not indicated, submit proposed joint layout, for Owner's approval. Fit exposed connections together to form hairline joints.
  - 1. Use weather cuts, miters, back caulk as needed. Use lengths that minimize joints.
- I. Hazardous Materials: Use products, cleaners, and installation materials that are not considered hazardous.
  - 1. If required, Contractor must submit MSDS for all products to be used onsite to Owner for approval. Owner shall have seven (7) calendar days to review and approve/disapprove of the product.

2. If required, Contractor must submit a weekly schedule detailing when and where approved products will be used on an hour-by-hour basis. This schedule must be submitted by 9:00 AM on Wednesday of the week prior to the scheduled work week.

### 3.6 PROGRESS CLEANING

- A. General: Clean Project site and work areas daily, including common areas. Coordinate progress cleaning for joint-use areas where more than one installer has worked. Enforce requirements strictly. Dispose of materials lawfully in compliance with Section 01 7419 "Construction Waste Management and Disposal."
  1. Comply with requirements in NFPA 241 for removal of combustible waste materials and debris.
  2. Do not hold materials more than seven (7) calendar days during normal weather or three (3) calendar days if the temperature is expected to rise above 80 degrees F.
  3. Containerize hazardous and unsanitary waste materials separately from other waste. Mark containers appropriately and dispose of legally, according to regulations.
  4. Do not use Owner receptacles.
  5. Recycle as outlined in Waste Management Plan in Section 01 7419.
- B. Site: Maintain Project site free of waste materials and debris.
- C. Work Areas: Clean areas where work is in progress to the level of cleanliness necessary for proper execution of the Work.
  1. Remove liquid spills promptly.
  2. Where dust would impair proper execution of the Work, broom-clean or vacuum the entire work area, as appropriate.
- D. Installed Work: Keep installed work clean. Clean installed surfaces according to written instructions of manufacturer or fabricator of product installed, using only cleaning materials specifically recommended. If specific cleaning materials are not recommended, use cleaning materials that are not hazardous to health or property and that will not damage exposed surfaces.
- E. Concealed Spaces: Remove debris from concealed spaces before enclosing the space.
- F. Exposed Surfaces in Finished Areas: Clean exposed surfaces and protect as necessary to ensure freedom from damage and deterioration at time of Substantial Completion.
- G. Waste Disposal: Burying or burning waste materials on-site will not be permitted. Washing waste materials down sewers or into waterways will not be permitted.
- H. During handling and installation, clean and protect construction in progress and adjoining materials already in place. Apply protective covering where required to ensure protection from damage or deterioration at Substantial Completion.
- I. Clean and provide maintenance on completed construction as frequently as necessary through the remainder of the construction period. Adjust and lubricate operable components to ensure operability without damaging effects.

- J. Limiting Exposures: Supervise construction operations to assure that no part of the construction, completed or in progress, is subject to harmful, dangerous, damaging or otherwise deleterious exposure during the construction period.

### 3.7 STARTING AND ADJUSTING

- A. Start equipment and operating components to confirm proper operation. Remove malfunctioning units, replace with new units and re-test.
- B. Adjust operating components for proper operation without binding. Adjust equipment for proper operation.
- C. Test each piece of equipment to verify proper operation. Test and adjust controls and safeties. Replace damaged and malfunctioning controls and equipment.
- D. Manufacturer's Field Service: If a factory-authorized service representative is required to inspect field-assembled components and equipment installation, comply with qualification requirements in Division 01 04 00 Section "Quality Requirements."

### 3.8 PROTECTION OF INSTALLED CONSTRUCTION

- A. Provide final protection and maintain conditions that ensure installed Work is without damage or deterioration at time of Substantial Completion.
- B. Comply with manufacturer's written instructions for temperature and relative humidity.

### 3.9 CORRECTION OF THE WORK

- A. Repair or remove and replace defective construction. Restore damaged substrates and finishes. Comply with requirements in Division 01 73 29 Section "Cutting and Patching."
  - 1. Repairing includes replacing defective parts, refinishing damaged surfaces, touching up with matching materials and properly adjusting operating equipment.
- B. Restore permanent facilities used during construction as well as landscapes and hardscapes to their original condition.
- C. Remove and replace damaged surfaces that are exposed to view if surfaces cannot be repaired without visible evidence of repair.
- D. Repair components that do not operate properly. Remove and replace operating components that cannot be repaired.
- E. Remove and replace chipped, scratched and broken glass or reflective surfaces.

**END OF SECTION 01 7300**

## SECTION 01 7329 CUTTING AND PATCHING

### PART 1 GENERAL

#### 1.1 RELATED DOCUMENTS

- A. Drawings and general provisions of the Contract, including General and Supplementary Conditions and other Division 01 Specification Sections, apply to this Section.

#### 1.2 SUMMARY

- A. This Section includes procedural requirements for cutting and patching.
- B. See Divisions 02 through 33 Sections for specific requirements and limitations applicable to cutting and patching individual parts of the Work. Not all Sections will be used.

#### 1.3 QUALITY ASSURANCE

- A. Structural Elements: Do not cut and patch structural elements in a manner that could change their load-carrying capacity or load-deflection ratio.
- B. Operational Elements: Do not cut and patch operating elements and related components in a manner that results in reducing their capacity to perform as intended or that results in increased maintenance or decreased operational life or safety.
- C. Miscellaneous Elements: Do not cut and patch miscellaneous elements or related components in a manner that could change their load-carrying capacity, that results in reducing their capacity to perform as intended, or that results in increased maintenance or decreased operational life or safety.
- D. Visual Requirements:
  - 1. Unless indicated otherwise, patching, extending or matching shall be performed as necessary to make the Work complete, with all components matching and consistent.
  - 2. Do not cut and patch construction in a manner that results in visual evidence of cutting and patching. Do not cut and patch construction exposed on the exterior or in occupied spaces in a manner that would, in Owner's opinion, reduce the building's aesthetic qualities. Remove and replace construction that has been cut and patched in a visually unsatisfactory manner.
  - 3. Patching materials shall meet the requirements of the jurisdictional code authorities.
  - 4. All patching procedures shall be reviewed with the Owner prior to proceeding.

#### 1.4 WARRANTY

- A. Existing Warranties: Remove, replace, patch and repair materials and surfaces cut or damaged during cutting and patching operations, by methods and with materials so as not to void existing warranties.

PART 2 PRODUCTS

2.1 MATERIALS

- A. General: Comply with requirements specified in other Sections.
- B. In-Place Materials: Use materials identical to in-place materials. For exposed surfaces, use materials that visually match in-place adjacent surfaces to the fullest extent possible.
  - 1. If identical materials are unavailable or cannot be used, use materials that, when installed, will match the visual and functional performance of in-place materials.

PART 3 EXECUTION

3.1 EXAMINATION

- A. Examine surfaces to be cut and patched and conditions under which cutting and patching are to be performed.
  - 1. Compatibility: Before patching, verify compatibility with and suitability of substrates, including compatibility with in-place finishes or primers.
  - 2. Proceed with installation only after unsafe or unsatisfactory conditions have been corrected.

3.2 PREPARATION

- A. Temporary Support: Provide temporary support of Work to be cut.
- B. Protection: Protect in-place construction during cutting and patching to prevent damage. Provide protection from adverse weather conditions for portions of Project that might be exposed during cutting and patching operations.
- C. Adjoining Areas: Avoid interference with use of adjoining areas or interruption of free passage to adjoining areas.
- D. Cut, move or remove items as necessary for access to alterations and renovations work; replace and restore at completion.
- E. Contact the Owner when unsuitable materials not marked for removal - such as rotted wood, rusted metals and deteriorated concrete and masonry are discovered.
- F. Remove debris and abandoned items from area and from concealed spaces.
- G. Prepare surfaces and remove surface finishes to provide for proper installation of new work and new finishes.

3.3 PERFORMANCE

- A. General: Employ skilled workers to perform cutting and patching. Proceed with cutting and patching at the earliest feasible time and complete without delay.

- B. Cutting: Cut in-place construction by sawing, drilling, breaking, chipping, grinding and similar operations, including excavation, using methods least likely to damage elements retained or adjoining construction. Provide appropriate dust control while cutting through surfaces. If possible, review proposed procedures with original Installer; comply with original Installer's written recommendations.
1. In general, use hand or small power tools designed for sawing and grinding, not hammering and chopping. Cut holes and slots as small as possible, neatly to size required and with minimum disturbance of adjacent surfaces. Temporarily cover openings when not in use.
  2. Finished Surfaces: Cut or drill from the exposed or finished side into concealed surfaces.
  3. Concrete and Masonry: Cut using a cutting machine, such as an abrasive saw or a diamond-core drill.
  4. Excavating and Backfilling: Comply with requirements in applicable Division 31 and 33 Sections (Sections may not be used) where required by cutting and patching operations.
  5. Proceed with patching after construction operations requiring cutting are complete.
- C. Patching: Patch construction by filling, repairing, refinishing, closing up and similar operations following performance of other Work. Patch with durable seams that are as invisible as possible. Provide materials and comply with installation requirements specified in other Sections.
1. Inspection: Where feasible, test and inspect patched areas after completion to demonstrate integrity of installation.
  2. Exposed Finishes: Restore exposed finishes of patched areas and extend finish restoration into retained adjoining construction in a manner that will eliminate evidence of patching and refinishing.
  3. Floors and Walls: Where walls or partitions that are removed extend one finished area into another, patch and repair floor and wall surfaces in the new space. Provide an even surface of uniform finish, color, texture and appearance. Remove in-place floor and wall coverings and replace with new materials, if necessary, to achieve uniform color and appearance.
  4. Ceilings: Patch, repair or rehang in-place ceilings as necessary to provide an even-plane surface of uniform appearance.
  5. Exterior Building Enclosure: Patch components in a manner that restores enclosure to a weathertight condition.
- D. Trim existing doors as necessary to clear new floor finishes; refinish trimmed areas.
- E. Where existing items are indicated as cut or reconfigured, cap and finish all exposed edges to match the existing construction to remain. Provide new or relocated supports spaced to be consistent with the installation.
- F. Cleaning: Clean areas and spaces where cutting and patching are performed. Completely remove paint, mortar, oils, putty and similar materials.

**END OF SECTION 01 7329**

**SECTION 01 7419  
CONSTRUCTION WASTE MANAGEMENT  
AND DISPOSAL**

PART 1 GENERAL

1.1 RELATED DOCUMENTS

- A. Drawings and general provisions of the Contract, including General and Supplementary Conditions, Project Documents, and other Division 01 Specification Sections, apply to this Section.

1.2 SUMMARY

- A. This Section includes administrative and procedural requirements for the following:
  - 1. Salvaging of non-hazardous demolition and construction waste.
  - 2. Recycling of non-hazardous demolition and construction waste.
  - 3. Disposing of non-hazardous demolition and construction waste.

1.3 DEFINITIONS

- A. Construction Waste: All non-hazardous building and site materials or other non-hazardous solid waste resulting from construction, remodeling, renovation, repair or land-clearing operations. Construction waste includes packaging and material that is recycled, reused, salvaged or disposed as garbage.
- B. Demolition Waste: All non-hazardous building and site materials or other non-hazardous solid waste resulting from demolition or selective demolition operations.
- C. Disposal: Removal off-site of demolition and construction waste and subsequent sale, recycling, reuse or deposit in landfill or incinerator acceptable to authorities having jurisdiction.
- D. Recycle: Recovery of demolition or construction waste for subsequent processing for the purpose of using the material in the manufacture of a new product.
  - 1. Source-Separated Recycling: The process of separating recyclable materials in separate containers as they are generated on the job-site. The separated materials are hauled directly to a recycling facility or transfer station.
  - 2. Co-mingled Recycling: The process of collecting mixed recyclable materials in one container on-site. The container is taken to a material recovery facility where materials are separated for recycling.
- E. Re-Use: Making use of a material without altering its form. Materials can be reused on-site or reused on other project off-site. Examples include, but are not limited to the following:
  - 1. Grinding of concrete for use as sub-base material.
  - 2. Chipping of land-clearing debris for use as mulch.

- F. Salvage: Recovery of demolition or construction waste and subsequent sale or re-use in another facility.
- G. Salvage and Re-use: Recovery of demolition or construction waste and subsequent incorporation into the Work.

#### 1.4 PERFORMANCE GOALS

- A. General: Material from demolition projects shall be recycled or reused whenever practicable (RCW 39.04.135). Contractor to develop a waste management plan that results in end-of-Project rates for salvage/recycling of fifty (50%) percent by weight of total waste generated by the Work by one or a combination of the following:
  - 1. Salvage.
  - 2. Reuse.
  - 3. Source-separated Recycling.
  - 4. Co-mingled Recycling.
- B. Salvage/Recycle Goals: Owner's goal is to salvage and recycle as much non-hazardous demolition and construction waste as possible including the following materials:
  - 1. Cardboard.
  - 2. Clean dimensional wood.
  - 3. Metals: Material banding, stud trim, ductwork, piping, rebar, roofing, other trim, steel, iron, galvanized sheet steel, stainless steel, aluminum, copper, zinc, lead, brass, and bronze.
  - 4. Gypsum board.

#### 1.5 SUBMITTALS

- A. Waste Management Plan: Submit three (3) copies of plan within seven (7) calendar days of date established for the Notice of Proceed.
- B. Waste Reduction Progress Reports: Electronically submit, concurrent with Final Application for Payment, the report to the Owner. Include separate reports for demolition and construction waste. Include the following information:
  - 1. Material category.
  - 2. Generation point of waste.
  - 3. Destination of waste.
  - 4. Total quantity of waste in tons.
  - 5. Quantity of waste salvaged, both estimated and actual in tons.
  - 6. Quantity of waste recycled, both estimated and actual in tons.
  - 7. Total quantity of waste recovered (salvaged plus recycled) in tons.
  - 8. Total quantity of waste recovered (salvaged plus recycled) as a percentage of total waste.
- C. Waste Reduction Calculations: Before request for Substantial Completion, electronically submit a copy of calculated end-of-Project rates for salvage, recycling, and disposal as a percentage of total waste generated by the Work to the Owner.
- D. Records of Donations: Indicate receipt and acceptance of salvageable waste donated to individuals and organizations. Indicate whether organization is tax exempt.

- E. Records of Sales: Indicate receipt and acceptance of salvageable waste sold to individuals and organizations. Indicate whether organization is tax exempt.
- F. Recycling and Processing Facility Records: Indicate receipt and acceptance of recyclable waste by recycling and processing facilities licensed to accept them. Include manifests, weight tickets, receipts and invoices. If waste is taken to a facility that landfills and recycles, include facility record of recycling rate for the period of construction.
- G. Landfill and Incinerator Disposal Records: Indicate receipt and acceptance of waste by landfills and incinerator facilities licensed to accept them. Include manifests, weight tickets, receipts and invoices.

#### 1.6 QUALITY ASSURANCE

- A. Regulatory Requirements: Conduct construction waste management activities in accordance with State of Washington RCW 70.95.240, Seattle Municipal Code Chapter 21.36 and all other applicable laws and ordinances.
- B. Review of the following publications and programs (request copies by calling King County Solid Waste Division at 206-477-4466)
  - 1. Construction Recycling Directory for Seattle/ King County.
  - 2. Contractors Guide: Save money and resources through job-site recycling and waste prevention.
  - 3. King County Solid Waste Division Report of Co-mingled Recycling Facilities (available at [www.metrokc.gov/dnrp/swd/construction-recycling/comingled.asp](http://www.metrokc.gov/dnrp/swd/construction-recycling/comingled.asp))

#### 1.7 WASTE MANAGEMENT PLAN

- A. General: Develop a plan consisting of waste identification, waste reduction work plan and cost/revenue analysis. Include separate sections in plan for demolition and construction waste. Indicate quantities by weight or volume, but use same units of measure throughout waste management plan.
- B. Waste Identification: Indicate anticipated types and quantities of demolition and construction waste generated by the Work. Include estimated quantities and assumptions for estimates.
- C. Waste Reduction Work Plan: List each type of waste and whether it will be salvaged, recycled or disposed of in landfill or incinerator. Include points of waste generation, total quantity of each type of waste, quantity for each means of recovery and handling and transportation procedures.
  - 1. Salvaged Materials for Reuse: For materials that will be salvaged and reused in this Project, describe methods for preparing salvaged materials before incorporation into the Work.
  - 2. Salvaged Materials for Sale: For materials that will be sold to individuals and organizations, include list of their names, addresses and telephone numbers.
  - 3. Salvaged Materials for Donation: For materials that will be donated to individuals and organizations, include list of their names, addresses and telephone numbers.

4. Recycled Materials: Include list of local receivers and processors and type of recycled materials each will accept. Include names, addresses and telephone numbers.
  5. Disposed Materials: Indicate how and where materials will be disposed of. Include name, address and telephone number of each landfill and incinerator facility.
  6. Handling and Transportation Procedures: Include method that will be used for separating recyclable waste including sizes of containers, container labeling and designated location on Project site where materials separation will be located.
- D. Cost/Revenue Analysis: Indicate total cost of waste disposal as if there was no waste management plan and net additional cost or net savings resulting from implementing waste management plan. Include the following:
1. Total quantity of waste.
  2. Estimated cost of disposal (cost per unit). Include hauling and tipping fees and cost of collection containers for each type of waste.
  3. Total cost of disposal (with no waste management).
  4. Savings in hauling and tipping fees that are avoided.
  5. Handling and transportation costs. Include cost of collection containers for each type of waste.
  6. Net additional cost or net savings from waste management plan.

PART 2 PRODUCTS (Not Used)

PART 3 EXECUTION

3.1 PLAN IMPLEMENTATION

- A. General: Implement waste management plan as approved by Owner. Provide handling, containers, storage, signage, transportation and other items as required to implement waste management plan during the entire duration of the Contract.
- B. Waste Management Coordinator: Contractor shall be responsible for implementing, monitoring, and reporting status of waste management work plan.
- C. Training: Train workers, subcontractors and suppliers on proper waste management procedures, as appropriate for the Work occurring at Project site.
  1. Distribute waste management plan to everyone concerned within one (1) day of submittal return. A hard copy should remain on site. Send the plan electronically to the Owner.
  2. Distribute waste management plan to entities when they first begin work on-site. Review plan procedures and locations established for salvage, recycling and disposal.
  3. The General Contractor will ensure that the waste plan is communicated to the crews and subcontractors on site. They will be informed of:
    - a. How materials should be separated, and why.
    - b. Where materials should go.
    - c. How often the materials will be collected and delivered to the appropriate facilities.
    - d. The importance of recycling, and KCHA's recycling goals for the project.

- D. Site Access and Temporary Controls: Conduct waste management operations to ensure minimum interference with roads, streets, walks, walkways and other adjacent occupied and used facilities.
  - 1. Designate and label specific areas on Project site necessary for separating materials that are to be salvaged, recycled, reused, donated and sold.
  - 2. Comply with Division 01 50 00 Section "Temporary Facilities and Controls" for controlling dust and dirt, environmental protection and noise control.
  - 3. Clearly label the recycling bins and waste containers on site.
  - 4. Post lists of recyclable and non-recyclable materials in many locations, in different languages.
  - 5. The General Contractor will provide feedback to the crew and subcontractors on the results of their efforts
  
- E. To the greatest extent possible, include in material purchasing agreements a waste reduction provision requesting that materials and equipment be delivered in packaging made of recyclable material, that they reduce the amount of packaging, that packaging be taken back for reuse or recycling, and to take back all unused product. Ensure that subcontractors require the same provisions in their purchase agreements.

### 3.2 SALVAGING DEMOLITION WASTE

- A. Salvaged Items for Reuse in the Work:
  - 1. Clean salvaged items.
  - 2. Pack or crate items after cleaning. Identify contents of containers.
  - 3. Store items in a secure area until installation.
  - 4. Protect items from damage during transport and storage.
  - 5. Install salvaged items to comply with installation requirements for new materials and equipment. Provide connections, supports and miscellaneous materials necessary to make items functional for use indicated.
  
- B. Salvaged Items for Sale and Donation: Not permitted on Project site.
  
- C. Salvaged Items for Owner's Use:
  - 1. Clean salvaged items.
  - 2. Pack or crate items after cleaning. Identify contents of containers.
  - 3. Store items in a secure area until delivery to Owner.
  - 4. Transport items to Owner's designated off-site storage area.
  - 5. Protect items from damage during transport and storage.

### 3.3 RECYCLING DEMOLITION AND CONSTRUCTION WASTE, GENERAL

- A. General: Recycle paper and beverage containers used by on-site workers.
  
- B. Recycling Receivers and Processors: The list below is provided for information only; available recycling receivers and processors include, but are not limited to, the following:
  - 1. Washington State Department of Ecology, Recycling, Northwest Region 425-649-7000.
  - 2. Industrial Materials Exchange (IMEX), Hazardous Waste Management Program, King County, Washington.

3. The “Recycling Plus Program Manual” published by the Washington State Clean Washington Center can be used to develop a job site reduction program. The manual includes a job-site recycling worksheet and form, tips on waste reduction, and other technical assistance. The manual also includes sample language for waste reduction requirements for subcontractors’ agreements, as well as sample provision for a full-service recycling agreement.
  4. LEED Reference Guide, Construction Waste Management section.
  5. Recovery 1 is a resource recovery, recycling and research facility dedicated to developing sustainable waste management systems. [www.recovery1.com](http://www.recovery1.com) or by phone at 800-949-5852.
  6. Total Reclaim offers a wide variety of innovative environmental services for management of electronics and other hard to handle materials, including fluorescent lamps, refrigerant gases and appliances. [www.totalreclaim.com](http://www.totalreclaim.com) or by phone 206-343-7443.
  7. “Contractors’ Guide for Preventing Waste and Recycling”  
<https://kingcounty.gov/~media/depts/dnrp/solid-waste/construction-recycling/documents/ConGuide.ashx?la=en>
  8. “Seattle/King County Construction Recycling Directory.”  
<https://kingcounty.gov/depts/dnrp/solid-waste/programs/green-building/county-green-building.aspx>
- C. Recycling Incentives: Revenues, savings, rebates, tax credits and other incentives received for recycling waste materials shall accrue to Owner.
- D. Procedures: Separate recyclable waste from other waste materials, trash and debris. Separate recyclable waste by type at Project site to the maximum extent practical.
1. Provide appropriately marked containers or bins for controlling recyclable waste until they are removed from Project site. Include list of acceptable and unacceptable materials at each container and bin.
    - a. Inspect containers and bins for contamination and remove contaminated materials if found.
  2. Stockpile processed materials on-site without intermixing with other materials. Place, grade and shape stockpiles to drain surface water. Cover to prevent windblown dust.
  3. Stockpile materials away from construction area. Do not store within drip line of remaining trees.
  4. Store components off the ground and protect from the weather.
  5. Remove recyclable waste off Owner's property and transport to recycling receiver or processor.
- 3.4 RECYCLING DEMOLITION WASTE
- A. Wood Materials: Sort and stack members according to size, type and length. Separate lumber, engineered wood products, panel products and treated wood materials.
  - B. Metals: Separate metals by type.
    1. Structural Steel: Stack members according to size, type of member and length.
    2. Remove and dispose of bolts, nuts, washers and other rough hardware.
  - C. Gypsum Board: Stack large clean pieces on wood pallets and store in a dry location. Remove edge trim and sort with other metals. Remove and dispose of fasteners.

- D. Equipment: Drain tanks, piping, and fixtures. Seal openings with caps or plugs. Protect equipment from exposure to weather.
- E. Plumbing Fixtures: Separate by type and size.
- F. Piping: Reduce piping to straight lengths and store by type and size. Separate supports, hangers, valves, sprinklers and other components by type and size.
- G. Lighting Fixtures: Separate lamps by type and protect from breakage.
- H. Electrical Devices: Separate switches, receptacles, switchgear, transformers, meters, panelboards, circuit breakers and other devices by type.
- I. Conduit: Reduce conduit to straight lengths and store by type and size.

### 3.5 RECYCLING CONSTRUCTION WASTE

- A. Packaging:
  - 1. Cardboard and Boxes: Break down packaging into flat sheets. Bundle and store in a dry location.
  - 2. Polystyrene Packaging: Separate and bag materials.
  - 3. Pallets: As much as possible, require deliveries using pallets to remove pallets from Project site. For pallets that remain on-site, break down pallets into component wood pieces and comply with requirements for recycling wood.
  - 4. Crates: Break down crates into component wood pieces and comply with requirements for recycling wood.
- B. Wood Materials:
  - 1. Clean Cut-Offs of Lumber: Grind or chip into small pieces.
  - 2. Clean Sawdust: Bag sawdust that does not contain painted or treated wood.
- C. Gypsum Board: Stack large clean pieces on wood pallets and store in a dry location.
  - 1. Clean Gypsum Board: Grind scraps of clean gypsum board using small mobile chipper or hammer mill. Screen out paper after grinding.

### 3.6 DISPOSAL OF WASTE

- A. General: Except for items or materials to be salvaged, recycled or otherwise reused, remove waste materials from Project site and legally dispose of them in a landfill or incinerator acceptable to authorities having jurisdiction.
  - 1. Except as otherwise specified, do not allow waste materials that are to be disposed of accumulate on-site.
  - 2. Remove and transport debris in a manner that will prevent spillage on adjacent surfaces and areas.
- B. Burning: Do not burn waste materials.
- C. Disposal: Transport waste materials off Owner's property and legally dispose of them.

**END OF SECTION 01 7419**

# Waste Disposal and Recycling Data Form



The resource conservation program at KCHA tracks the disposal and recycling data for all KCHA activities. These includes all of the waste and recycling generated by residents, food composting, yard waste composting, unit-improvement waste, illegal dumping waste, and all waste created during the construction and demolition process.

Our goals for all of these areas are:

1. Track the diversion of our waste and improve when possible
2. Meet KCHA recycling goals.

Please provide estimates, to the best of your ability, about the projected waste being generated on this project as well as how much of that waste is being recycled vs disposed. If estimates aren't possible, then we will need this information at project close-out.

**Project Name:** GREENBRIDGE APT. BUILDINGS A, B & C WALKWAY REPAIRS

**Project Address:** 9915 7TH AVE. SEATTLE, WA. 98106

**Work Order No.:** \_\_\_\_\_ **Job No.:** AW2501531

DESCRIPTION	WEIGHT	QUANTITY (Circle One)		
		Lbs.	CY	Tons
<b>Total Waste Generated**</b>		Lbs.	CY	Tons
<b>Waste Disposed</b>		Lbs.	CY	Tons
<b>Waste Recycled</b>		Lbs.	CY	Tons
**Waste Disposed plus Waste Recycled should equal Total Waste Generated				
<b>What % of the total waste do you estimate you will recycle?</b>				

The following tables identify materials expected on this project, the quantities generated, whether they will be disposed or recycled, and what facility they will be disposed or recycled at.

DEMOLITION PHASE				
MATERIAL	QUANTITY Lbs./CY/Tons	DISPOSAL / RECYCLE? (CIRCLE ONE)		DISPOSAL OR RECYCLING FACILITY
		Disposal	Recycle	
		Disposal	Recycle	
		Disposal	Recycle	
		Disposal	Recycle	
		Disposal	Recycle	
		Disposal	Recycle	

Example: Roofing, 3 tons, Recycle, DTG Recycle

CONSTRUCTION PHASE				
MATERIAL	QUANTITY Lbs./CY/Tons	DISPOSAL / RECYCLE? (CIRCLE ONE)		DISPOSAL OR RECYCLING FACILITY
		Disposal	Recycle	
		Disposal	Recycle	
		Disposal	Recycle	
		Disposal	Recycle	
		Disposal	Recycle	
		Disposal	Recycle	

Example: Misc. Con. Mat., 30 cy, Recycle, Waste Management

## SECTION 01 7700 CLOSEOUT PROCEDURES

### PART 1 GENERAL

#### 1.1 RELATED DOCUMENTS

- A. Drawings and general provisions of the Contract, including General and Supplementary Conditions and other Division 01 Specification Sections, apply to this Section.

#### 1.2 SUMMARY

- A. This Section includes administrative and procedural requirements for contract closeout, including, but not limited to, the following:
  - 1. Inspection procedures.
  - 2. Warranties.
  - 3. Final cleaning.
- B. See the Owner-Contractor Contract for requirements for Applications for Payment for Substantial and Final Completion.
- C. See Division 01 7839 Section "Project Record Documents" for submitting Record Drawings, Record Specifications and Record Product Data.
- D. See Division 01 7823 Section "Operation and Maintenance Data" for operation and maintenance manual requirements.
- E. See Divisions 02 through 33 Sections for specific closeout and special cleaning requirements for the Work in those Sections. Not all Sections will be used.

#### 1.3 SUBSTANTIAL COMPLETION (Refer to Article 9.8 AIA A201-2017)

- A. Preliminary Procedures: Before requesting inspection for determining date of Substantial Completion, complete the following. List items below that are incomplete in request.
  - 1. Prepare a list of items to be completed and corrected (punch list), the value of items on the list, and reasons why the Work is not complete.
  - 2. Advise Owner of pending insurance changeover requirements.
  - 3. Submit specific warranties, workmanship bonds, maintenance service agreements, final certifications and similar documents (to be included in O&M Manuals).
  - 4. Obtain and submit to Owner, the releases permitting Owner unrestricted use of the Work and access to services and utilities. Include occupancy permits, operating certificates, and similar releases.
  - 5. Prepare and submit Project Record Documents, operation and maintenance manuals, damage or settlement surveys, property surveys and similar final record information to the Owner.
  - 6. Deliver tools, spare parts, extra materials and similar items to location designated by Owner. Label with manufacturer's name and model number where applicable.
  - 7. Make final changeover of permanent locks and deliver keys to Owner. Advise Owner's personnel of changeover in security provisions.

8. Complete startup testing of systems.
  9. Submit test/adjust/balance records to the Owner.
  10. Terminate and remove temporary facilities from Project site, along with mockups, construction tools and similar elements.
  11. Advise Owner of changeover in heat and other utilities.
  12. Submit changeover information related to Owner's occupancy, use, operation and maintenance.
  13. Complete final cleaning requirements, including touchup painting.
  14. Touch up and otherwise repair and restore marred exposed finishes to eliminate visual defects.
  15. Provide training on all newly installed systems by qualified personnel. Training will be presented to those that use the equipment, i.e. tenants site staff, facility users.
- B. Inspection: Submit a written request for inspection for Substantial Completion to the Owner. On receipt of request, Owner will either proceed with inspection or notify Contractor of unfulfilled requirements. Owner will prepare the Certificate of Substantial Completion after inspection or will notify Contractor of items, either on Contractor's list or additional items identified by Owner, that must be completed or corrected before certificate will be issued.
1. Re-inspection: Request re-inspection when the Work identified in previous inspections as incomplete is completed or corrected.
  2. Results of completed inspection will form the basis of requirements for Final Completion.

#### 1.4 CONTRACT COMPLETION (Refer to Article 9.10 in AIA A201-2017)

- A. Preliminary Procedures: Before requesting final inspection for determining date of Contract Completion, complete the following:
1. Submit a final Application for Payment according to the Owner-Contractor Contract provisions to the Owner.
  2. Submit to the Owner, a certified copy of Owner's Substantial Completion inspection list of items to be completed or corrected (punch list), endorsed and dated by Owner. The certified copy of the list shall state that each item has been completed or otherwise resolved for acceptance.
  3. Submit evidence of final, continuing insurance coverage complying with insurance requirements to the Owner.
  4. Instruct Owner's personnel in operation, adjustment and maintenance of products, equipment and systems.
- B. Inspection: Submit a written request for final inspection for acceptance to the Owner. On receipt of request, Owner will either proceed with inspection or notify Contractor of unfulfilled requirements. Owner will notify Contractor of construction that must be completed or corrected before certificate will be issued.
1. Re-inspection: Request re-inspection when the Work identified in previous inspections as incomplete is completed or corrected.

#### 1.5 LIST OF INCOMPLETE ITEMS (PUNCH LIST)

- A. Preparation: After Contractor has performed own Quality Control of the Work, Contractor will notify and schedule punch list inspection with Owner and other team

members. Owner will document items needing correction on Owner provided form listing area inspected and deficient item needing correction. Owner will provide Contractor with copy of punch list after inspection is completed. Owner has right to stop inspection due to quantity of repetitious items identified by Owner, or if Contractor has not performed own Quality Control of the Work

1. Organize list of spaces in sequential order.
2. Organize items applying to each space by major element, including categories for ceiling, individual walls, floors, equipment and building systems.

#### 1.6 WARRANTIES (Refer to Article 3.5 in AIA A201-2017)

- A. Submittal Time: Submit written warranties on request of Owner for designated portions of the Work where commencement of warranties other than date of Substantial Completion is indicated.
- B. Organize warranty documents into an orderly sequence based on the table of contents of the Project Manual.
  1. Bind warranties and bonds in heavy-duty, 3-ring, vinyl-covered, loose-leaf binders, thickness as necessary to accommodate contents, and sized to receive 8-1/2-by-11-inch paper.
  2. Provide heavy paper dividers with plastic-covered tabs for each separate warranty. Mark tab to identify the product or installation. Provide a typed description of the product or installation, including the name of the product and the name, address and telephone number of Installer.
  3. Identify each binder on the front and spine with the typed or printed title "WARRANTIES," Project name and name of Contractor.
- C. Provide additional copies of each warranty to include in operation and maintenance manuals.

### PART 2 PRODUCTS

#### 2.1 MATERIALS

- A. Cleaning Agents: Use cleaning materials and agents recommended by manufacturer or fabricator of the surface to be cleaned. Do not use cleaning agents that are potentially hazardous to health or property or that might damage finished surfaces.

### PART 3 EXECUTION

#### 3.1 FINAL CLEANING

- A. General: Provide final cleaning. Conduct cleaning and waste-removal operations to comply with local laws and ordinances and Federal and local environmental and anti-pollution regulations.
- B. Cleaning: Employ experienced workers or professional cleaners for final cleaning. Clean each surface or unit to condition expected in an average commercial building cleaning and maintenance program. Comply with manufacturer's written instructions.

1. Complete the following cleaning operations before requesting inspection for certification of Substantial Completion for entire Project or for a portion of Project:
  - a. Clean Project site, yard and grounds, in areas disturbed by construction activities, including landscape development areas, of rubbish, waste material, litter and other foreign substances.
  - b. Sweep paved areas broom clean. Remove petrochemical spills, stains and other foreign deposits.
  - c. Remove tools, construction equipment, machinery and surplus material from Project site.
  - d. Clean exposed exterior and interior hard-surfaced finishes to a dirt-free condition, free of stains, films and similar foreign substances. Avoid disturbing natural weathering of exterior surfaces. Restore reflective surfaces to their original condition.
  - e. Sweep concrete floors broom clean in unoccupied spaces.
  - f. Vacuum carpet and similar soft surfaces, removing debris and excess nap; shampoo if visible soil or stains remain.
  - g. Clean transparent materials, including mirrors and glass in doors and windows. Remove glazing compounds and other noticeable, vision-obscuring materials. Replace chipped or broken glass and other damaged transparent materials. Polish mirrors and glass, taking care not to scratch surfaces.
  - h. Remove labels that are not permanent.
  - i. Touch up and otherwise repair and restore marred, exposed finishes and surfaces. Replace finishes and surfaces that cannot be satisfactorily repaired or restored or that already show evidence of repair or restoration.
    - 1) Do not paint over "UL" and similar labels, including mechanical and electrical nameplates.
  - j. Wipe surfaces of mechanical and electrical equipment and similar equipment. Remove excess lubrication, paint and mortar droppings and other foreign substances.
  - k. Replace parts subject to unusual operating conditions.
  - l. Clean plumbing fixtures to a sanitary condition, free of stains, including stains resulting from water exposure.
  - m. Replace disposable air filters and clean permanent air filters. Clean exposed surfaces of diffusers, registers and grills.
  - n. Clean light fixtures, lamps, globes and reflectors to function with full efficiency. Replace burned-out bulbs and those noticeably dimmed by hours of use, and defective or noisy starters in fluorescent and mercury vapor fixtures to comply with requirements for new fixtures.
  - o. Leave Project clean and ready for occupancy.
- C. Comply with safety standards for cleaning. Do not burn waste materials. Do not bury debris or excess materials on Owner's property. Do not discharge volatile, harmful or dangerous materials into drainage systems. Remove waste materials from Project site and dispose of lawfully.

**END OF SECTION 01 7700**

**SECTION 01 7823**  
**OPERATION AND MAINTENANCE DATA**

PART 1 GENERAL

1.1 RELATED DOCUMENTS

- A. Drawings and general provisions of the Contract, including General and Supplementary Conditions and other Division 01 Specification Sections, apply to this Section.

1.2 SUMMARY

- A. This Section includes administrative and procedural requirements for preparing operation and maintenance manuals, including the following:
  - 1. Operation manuals for systems, subsystems, and equipment Maintenance manuals for the care and maintenance of products, materials, finishes, systems, and equipment.
- B. See Divisions 02 through 33 Sections for specific operation and maintenance manual requirements for the Work in those Sections. Every Division may not be used.

1.3 SUBMITTALS

- A. Manual: Submit one (1) electronic copy of each manual in final form at least fifteen (15) calendar days before final inspection. Owner will return copy with comments within fifteen (15) calendar days after final inspection.
  - 1. Correct or modify each manual to comply with Owner's comments. Submit two (2) hard copies and one (1) electronic copy on Compact Disk of each corrected manual within fifteen (15) calendar days of receipt of Owner's comments.

PART 2 - PRODUCTS

2.1 MANUALS- GENERAL

- A. Organization: Unless otherwise indicated, organize each manual into a separate section for each system and subsystem, and a separate section for each piece of equipment not part of a system. Each manual shall contain a title page, table of contents and manual contents.
- B. Title Page: Enclose title page in transparent plastic sleeve. Include the following information:
  - 1. Subject matter included in manual.
  - 2. Name and address of Project.
  - 3. Name and address of Owner.
  - 4. Date of submittal.
  - 5. Name, address and telephone number of Contractor.
  - 6. Name and address of Architect.
  - 7. Cross-reference to related systems in other operation and maintenance manuals.

- C. Table of Contents: List each product included in manual, identified by product name, indexed to the content of the volume, and cross-referenced to Specification Section number in Project Manual.
- D. Manual Contents: Organize into sets of manageable size. Arrange contents alphabetically by system, subsystem and equipment. If possible, assemble instructions for subsystems, equipment and components of one (1) system into a single binder.
  - 1. Binders: Heavy-duty, 3-ring, vinyl-covered, loose-leaf binders, in thickness necessary to accommodate contents, sized to hold 8-1/2-by-11-inch paper; with clear plastic sleeve on spine to hold label describing contents and with pockets inside covers to hold folded oversize sheets.
    - a. Identify each binder on front and spine, with printed title "OPERATION AND MAINTENANCE MANUAL," Project title or name, and subject matter of contents. Indicate volume number for multiple-volume sets.
  - 2. Dividers: Heavy-paper dividers with plastic-covered tabs for each section. Mark each tab to indicate contents. Include typed list of products and major components of equipment included in the section on each divider, cross-referenced to Specification Section number and title of Project Manual.
  - 3. Protective Plastic Sleeves: Transparent plastic sleeves designed to enclose diagnostic software diskettes for computerized electronic equipment.
  - 4. Drawings: Attach reinforced, punched binder tabs on drawings and bind with text.
    - a. If oversize drawings are necessary, fold drawings to same size as text pages and use as foldouts.
    - b. If drawings are too large to be used as foldouts, fold and place drawings in labeled envelopes and bind envelopes in rear of manual. At appropriate locations in manual, insert typewritten pages indicating drawing titles, descriptions of contents and drawing locations.

## 2.2 OPERATION MANUALS

- A. Content: In addition to requirements in this Section, include operation data required in individual Specification Sections and equipment descriptions, operating standards, operating procedures, operating logs, wiring and control diagrams, and license requirements.
- B. Descriptions: Include the following:
  - 1. Product name and model number.
  - 2. Manufacturer's name.
  - 3. Equipment identification with serial number of each component.
  - 4. Equipment function.
  - 5. Operating characteristics.
  - 6. Limiting conditions.
  - 7. Performance curves.
  - 8. Engineering data and tests.
  - 9. Complete nomenclature and number of replacement parts.
- C. Operating Procedures: Include start-up, break-in and control procedures; stopping and normal shutdown instructions; routine, normal, seasonal and weekend operating instructions; and required sequences for electric or electronic systems.

- D. Systems and Equipment Controls: Describe the sequence of operation and diagram controls as installed.
- E. Piped Systems: Diagram piping as installed and identify color-coding where required for identification.

### 2.3 PRODUCT MAINTENANCE MANUAL

- A. Content: Organize manual into a separate section for each product, material and finish. Include source information, product information, maintenance procedures, repair materials and sources, and warranties and bonds, as described below.
- B. Source Information: List each product included in manual; identify by product name and arrange to match manual's table of contents. For each product, list name, address and telephone number of Installer or supplier and maintenance service agent, and cross-reference Specification Section number and title in Project Manual.
- C. Product Information: Include the following, as applicable:
  - 1. Product name and model number.
  - 2. Manufacturer's name.
  - 3. Color, pattern and texture.
  - 4. Material and chemical composition.
  - 5. Re-ordering information for specially manufactured products.
- D. Maintenance Procedures: Include manufacturer's written recommendations and inspection procedures, types of cleaning agents, methods of cleaning, schedule for cleaning and maintenance, and repair instructions.
- E. Repair Materials and Sources: Include lists of materials and local sources of materials and related services.
- F. Warranties and Bonds: Include copies of warranties and bonds and lists of circumstances and conditions that would affect validity of warranties or bonds.

### 2.4 SYSTEMS AND EQUIPMENT MAINTENANCE MANUAL

- A. Content: For each system, subsystem and piece of equipment not part of a system, include source information, manufacturers' maintenance documentation, maintenance procedures, maintenance and service schedules, spare parts list and source information, maintenance service contracts, and warranty and bond information, as described below.
- B. Source Information: List each system, subsystem, and piece of equipment included in manual; identify by product name and arrange to match manual's table of contents. For each product, list name, address and telephone number of Installer or supplier and maintenance service agent, and cross-reference Specification Section number and title in Project Manual.
- C. Manufacturers' Maintenance Documentation: Manufacturers' maintenance documentation including maintenance instructions, drawings and diagrams for maintenance, nomenclature of parts and components, and recommended spare parts for each component part or piece of equipment.

- D. Maintenance Procedures: Include test and inspection instructions, troubleshooting guide, disassembly instructions, and adjusting instructions that detail essential maintenance procedures.
- E. Maintenance and Service Schedules: Include service and lubrication requirements, list of required lubricants for equipment, and separate schedules for preventive and routine maintenance and service with standard time allotment.
- F. Spare Parts List and Source Information: Include lists of replacement and repair parts, with parts identified and cross-referenced to manufacturers' maintenance documentation and local sources of maintenance materials and related services.
- G. Maintenance Service Contracts: Include copies of maintenance agreements with name and telephone number of service agent.
- H. Warranties and Bonds: Include copies of warranties and bonds and lists of circumstances and conditions that would affect validity of warranties or bonds.

### PART 3 EXECUTION

#### 3.1 MANUAL PREPARATION

- A. Product Maintenance Manual: Assemble a complete set of maintenance data indicating care and maintenance of each product, material and finish incorporated into the Work.
- B. Operation and Maintenance Manuals: Assemble a complete set of operation and maintenance data indicating operation and maintenance of each system, subsystem and piece of equipment not part of a system.
- C. Manufacturers' Data: Where manuals contain manufacturers' standard printed data, include only sheets pertinent to product or component installed. Mark each sheet to identify each product or component incorporated into the Work. If data includes more than one (1) item in a tabular format, identify each item using appropriate references from the Contract Documents. Identify data applicable to the Work and delete references to information not applicable.
- D. Drawings: Prepare drawings supplementing manufacturers' printed data to illustrate the relationship of component parts of equipment and systems and to illustrate control sequence and flow diagrams. Coordinate these drawings with information contained in Record Drawings to ensure correct illustration of completed installation.
  - 1. Do not use original Project Record Documents as part of operation and maintenance manuals.
- E. Comply with Division 01 7700 Section "Closeout Procedures" for schedule for submitting operation and maintenance documentation.

**END OF SECTION 01 7823**

**SECTION 01 7839**  
**PROJECT RECORD DOCUMENTS**

PART 1 GENERAL

1.1 RELATED DOCUMENTS

- A. Drawings and general provisions of the Contract, including General and Supplementary Conditions and other Division 01 Specification Sections, apply to this Section.

1.2 SUMMARY

- A. This Section includes administrative and procedural requirements for Project Record Documents, including the following:
  - 1. Record Drawings.
  - 2. Record Specifications.
  - 3. Record Product Data.
- B. See Division 01 7823 Section "Operation and Maintenance Data" for operation and maintenance manual requirements.
- C. See Divisions 02 through 33 Sections for specific requirements for Project Record Documents of the Work in those Sections. Every Division may not be used.

1.3 CLOSEOUT SUBMITTALS

- A. Record Drawings: Submit to Owner PDF **and CAD** files of scanned record prints and three (3) sets of prints.
- B. Record Specifications: Submit annotated PDF electronic files of Project's Specifications, including addenda and contract modifications to the Owner.
- C. Record Product Data: Submit to the Owner, annotated PDF electronic files and directories of each submittal.
  - 1. Where record Product Data are required as part of operation and maintenance manuals, submit duplicate marked-up Product Data as a component of manual.
- D. Miscellaneous Record Submittals: See other Specification Sections for miscellaneous recordkeeping requirements and submittals in connection with various construction activities.
- E. Submit annotated PDF electronic files and directories of each submittal.

PART 2 PRODUCTS

2.1 RECORD DRAWINGS

- A. Record Prints: Maintain one (1) set of black-line white prints of the Contract Drawings and Shop Drawings.

1. Preparation: Mark Record Prints to show the actual installation where installation varies from that shown originally. Require individual or entity who obtained record data, whether individual or entity is Installer, subcontractor or similar entity, to prepare the marked-up Record Prints.
    - a. Give particular attention to information on concealed elements that would be difficult to identify or measure and record later.
    - b. Record data as soon as possible after obtaining it. Record and check the markup before enclosing concealed installations.
  2. Mark the Contract Drawings or Shop Drawings, whichever is most capable of showing actual physical conditions, completely and accurately. If Shop Drawings are marked, show cross-reference on the Contract Drawings.
  3. Mark record sets with erasable, red-colored pencil. Use other colors to distinguish between changes for different categories of the Work at same location.
  4. Note Field Authorization numbers, alternate numbers, Change Order numbers, and similar identification, where applicable.
- B. Format: Identify and date each Record Drawing; include the designation "PROJECT RECORD DRAWING" in a prominent location.
1. Record Prints: Organize Record Prints and newly prepared Record Drawings into manageable sets. Bind each set with durable paper cover sheets. Include identification on cover sheets.
  2. Identification: As follows:
    - a. Project name.
    - b. Date.
    - c. Designation "PROJECT RECORD DRAWINGS."
    - d. Name of Architect.
    - e. Name of Contractor.

## 2.2 RECORD SPECIFICATIONS

- A. Preparation: Mark Specifications to indicate the actual product installation where installation varies from that indicated in Specifications, addenda and contract modifications.
1. Give particular attention to information on concealed products and installations that cannot be readily identified and recorded later.
  2. Mark copy with the proprietary name and model number of products, materials, and equipment furnished, including substitutions and product options selected.
  3. Record the name of manufacturer, supplier, Installer and other information necessary to provide a record of selections made.
  4. Note related Change Orders, Record Product Data and Record Drawings where applicable.

## 2.3 RECORD PRODUCT DATA

- A. Preparation: Mark Product Data to indicate the actual product installation where installation varies substantially from that indicated in Product Data submittal.
1. Give particular attention to information on concealed products and installations that cannot be readily identified and recorded later.
  2. Include significant changes in the product delivered to Project site and changes in manufacturer's written instructions for installation.

3. Note related Change Orders, Record Specifications and Record Drawings where applicable.

2.4 MISCELLANEOUS RECORD SUBMITTALS

- A. Assemble miscellaneous records required by other Specification Sections for miscellaneous record keeping and submittal in connection with actual performance of the Work. Bind or file miscellaneous records and identify each, ready for continued use and reference.

PART 3 EXECUTION

3.1 RECORDING AND MAINTENANCE

- A. Recording: Maintain one (1) copy of each submittal during the construction period for Project Record Document purposes. Post changes and modifications to Project Record Documents as they occur; do not wait until the end of Project.
- B. Maintenance of Record Documents and Samples: Store Record Documents and Samples in the field office apart from the Contract Documents used for construction. Do not use Project Record Documents for construction purposes. Maintain Record Documents in good order and in a clean, dry, legible condition, protected from deterioration and loss. Provide access to Project Record Documents for Owner's reference during normal working hours.

**END OF SECTION 01 7839**

# G703 - Continuation Sheet

APPLICATION NO:

06 FINAL

APPLICATION DATE:

04.19.21

PERIOD FROM:

04.01.21

PERIOD TO:

04.19.21

SITE NAME - PROJECT NAME; Contract No. CCxxxxx65

A ITEM NO.	B DESCRIPTION OF WORK	C SCHEDULED VALUE	D WORK COMPLETED		F MATERIALS PRESENTLY STORED (NOT IN D OR E)	G TOTAL COMPLETED & STORED TO DATE (D + E + F)		H BALANCE TO FINISH (C - G)	I RETAINAGE (AGGREGATE TO DATE)
			FROM PREVIOUS APPLICATION(S) (G)	THIS PERIOD		% (G ÷ C)			
	Allowance & Contingencies	29,000.00	18,851.74	10,148.26	0.00	29,000.00	100.00%	0.00	1,450.00
	Close out	13,523.33	6,761.00	6,762.33	0.00	13,523.33	100.00%	0.00	676.17
	Bond & Insurance	24,050.00	24,050.00	0.00	0.00	24,050.00	100.00%	0.00	1,202.50
	Mobilization	17,500.00	17,500.00	0.00	0.00	17,500.00	100.00%	0.00	875.00
	Demo Siding and Windows	30,000.00	30,000.00	0.00	0.00	30,000.00	100.00%	0.00	1,500.00
	Frame & GWB F/P, Door, Storage	19,000.00	19,000.00	0.00	0.00	19,000.00	100.00%	0.00	950.00
	Deck Coatings	15,500.00	15,500.00	0.00	0.00	15,500.00	100.00%	0.00	775.00
	Deck Railings	23,500.00	21,150.00	2,350.00	0.00	23,500.00	100.00%	0.00	1,175.00
	Roofing incl Ladders and Hatches	57,300.00	28,650.00	28,650.00	0.00	57,300.00	100.00%	0.00	2,865.00
	Roof Framing/Backing/Blocking	11,600.00	10,600.00	1,000.00	0.00	11,600.00	100.00%	0.00	580.00
	Siding and Flashing Materials	43,000.00	43,000.00	0.00	0.00	43,000.00	100.00%	0.00	2,150.00
	Siding Labor	47,000.00	45,000.00	2,000.00	0.00	47,000.00	100.00%	0.00	2,350.00
	Window Materials	16,000.00	16,000.00	0.00	0.00	16,000.00	100.00%	0.00	800.00
	Window Labor	15,000.00	15,000.00	0.00	0.00	15,000.00	100.00%	0.00	750.00
	Patio Door Materials	9,600.00	9,600.00	0.00	0.00	9,600.00	100.00%	0.00	480.00
	Patio Door Labor	9,800.00	9,800.00	0.00	0.00	9,800.00	100.00%	0.00	490.00
	Exterior Doors & Hardware Materials	13,500.00	13,500.00	0.00	0.00	13,500.00	100.00%	0.00	675.00
	Exterior Door Labor	10,625.00	10,625.00	0.00	0.00	10,625.00	100.00%	0.00	531.25
	Door Hardware Materials	2,200.00	2,200.00	0.00	0.00	2,200.00	100.00%	0.00	110.00
	Gutters	4,200.00	0.00	4,200.00	0.00	4,200.00	100.00%	0.00	210.00
	Flameblock Labor	15,000.00	15,000.00	0.00	0.00	15,000.00	100.00%	0.00	750.00
	Flameblock Materials	14,000.00	14,000.00	0.00	0.00	14,000.00	100.00%	0.00	700.00
	Blinds	8,500.00	8,500.00	0.00	0.00	8,500.00	100.00%	0.00	425.00
	Electrical & Lighting Fixtures	12,800.00	12,800.00	0.00	0.00	12,800.00	100.00%	0.00	640.00
	Exterior Painting	18,000.00	17,000.00	1,000.00	0.00	18,000.00	100.00%	0.00	900.00
	Indirect Costs/Overhead/Profit	103,569.63	90,210.00	13,359.63	0.00	103,569.63	100.00%	0.00	5,178.48
	CO 1 - Contingency	(8,218.97)	0.00	(8,218.97)	0.00	(8,218.97)	100.00%	0.00	(410.95)
	<b>TOTALS</b>	<b>575,548.99</b>	<b>514,297.74</b>	<b>61,251.25</b>	<b>0.00</b>	<b>575,548.99</b>	<b>100.00%</b>	<b>0.00</b>	<b>28,777.45</b>
	<b>5% RETAINAGE</b>	<b>28,777.45</b>	<b>25,714.89</b>	<b>3,062.56</b>	<b>0.00</b>	<b>28,777.45</b>			
	<b>TOTALS LESS RETAINAGE</b>	<b>546,771.54</b>	<b>488,582.85</b>	<b>58,188.69</b>	<b>0.00</b>	<b>546,771.54</b>		<b>0.00</b>	<b>28,777.45</b>
	<b>TOTAL BALANCE TO FINISH ( H + I )</b>								<b>28,777.45</b>
	<b>NET CHANGE ORDERS THIS PERIOD:</b>	<b>(8,218.97)</b>	<b>CHANGE ORDERS APPROVED THIS PERIOD (LIST C/O #s)</b>			<b>1</b>			
	<b>NET C/O ADDITIONS (THIS PERIOD):</b>	<b>0.00</b>	<b>NET C/O DEDUCTIONS (THIS PERIOD):</b>			<b>(8,218.97)</b>			
	<b>TOTAL CHANGE ORDERS TO DATE:</b>	<b>(8,218.97)</b>							

# Form G702

V - 105694

## Application and Certificate for Payment

<b>TO OWNER:</b>	<b>King County Housing Authority</b> Attn: Capital Construction Dept. 700 Andover Park W. Suite C Tukwila, WA 98188	<b>PROJECT NAME / SCOPE OF WORK:</b>	<b>SITE NAME</b>  PROJECT NAME	<b>APPLICATION NO:</b> 06 FINAL	<b>PERIOD TO:</b> 04.19.21	<b>Distribution to:</b> OWNER: <input checked="" type="checkbox"/> ARCHITECT: <input type="checkbox"/> CONTRACTOR: <input type="checkbox"/> FIELD: <input type="checkbox"/>
<b>FROM CONTRACTOR:</b>	<b>CONTRACTOR NAME</b> CONTRACTOR ADDRESS CITY, STATE, ZIP	<b>VIA ARCHITECT:</b>	<b>ARC</b> 119 S. MAIN ST. SUITE 200 SEATTLE, WA 98104-2579	<b>CONTRACT NO:</b> CCxxxxx65	<b>CONTRACT DATE:</b> 11/16/2020	
				<b>NTP DATE:</b> 11/16/2020		
				<b>PROJECT NO:</b> 215.1B		
				<b>WORK ORDER NO:</b> 1243		

### CONTRACTOR'S APPLICATION FOR PAYMENT

Application is made for payment, as shown below, in connection with the Contract. Continuation Sheet, Form G703, is attached.

1. ORIGINAL CONTRACT SUM.....	\$583,767.96
2. NET CHANGE BY CHANGE ORDERS.....	(\$8,218.97)
3. CONTRACT SUM TO DATE (Line 1 +/- 2).....	\$575,548.99
4. TOTAL COMPLETED & STORED TO DATE (Column G on G703).....	\$575,548.99
<b>5. RETAINAGE:</b>	
a. <u>5</u> % of Completed Work (Column D + E on G703: \$575,548.99 )=	\$28,777.45
b. <u>5</u> % of Stored Material (Column F on G703: \$0.00 )=	\$0.00
Total Retainage (Lines 5a + 5b or Total in Column I of G703).....	\$28,777.45
6. TOTAL EARNED LESS RETAINAGE..... (Line 4 Less Line 5 Total)	\$546,771.54
7. LESS PREVIOUS CERTIFICATES FOR PAYMENT..... (Line 6 from prior Certificate)	\$488,582.85
8. CURRENT PAYMENT DUE.....	\$58,188.69
9. BALANCE TO FINISH, INCLUDING RETAINAGE (Line 3 Less Line 6)	\$28,777.45

The undersigned Contractor certifies that to the best of the Contractor's knowledge, information and belief the Work covered by this Application for Payment has been completed in accordance with the Contract Documents, that all amounts have been paid by the Contractor for Work for which previous Certificates for Payment were issued and payments received from the Owner, and that current payment shown herein is now due.

**CONTRACTOR:**  
By: \_\_\_\_\_ Date: \_\_\_\_\_  
State of: \_\_\_\_\_  
County of: \_\_\_\_\_  
Subscribed and sworn to before  
me this \_\_\_\_\_ day of \_\_\_\_\_  
Notary Public: \_\_\_\_\_  
My Commission expires: \_\_\_\_\_

### OWNER'S REPRESENTATIVE CERTIFICATE FOR PAYMENT

In accordance with the Contract Documents, based on on-site observations and the data comprising this application, the Owner's Representative certifies to the Owner that to the best of the Representative's knowledge, information and belief the Work has progressed as indicated, the quality of the Work is in accordance with the Contract Documents, and the Contract is entitled to payment of the AMOUNT CERTIFIED.

**AMOUNT CERTIFIED**..... \$58,188.69

(Attach explanation if amount certified differs from the amount applied. Initial all figures on this Application and on the Continuation Sheet that are changed to conform with the amount certified.)

**OWNER'S REPRESENTATIVE:**  
By: \_\_\_\_\_ Date: \_\_\_\_\_

This Certificate is not negotiable. The AMOUNT CERTIFIED is payable only to the Contractor named herein. Issuance, payment and acceptance of payment are without prejudice to any rights of the Owner or Contractor under this Contract.

CHANGE ORDER SUMMARY	ADDITIONS	DEDUCTIONS
Total changes approved in previous months by Owner	\$0.00	\$0.00
Total approved this month. (CO numbers listed below)	\$0.00	(\$8,218.97)
#s: 1 TOTALS	\$0.00	(\$8,218.97)
NET CHANGES by Change Order		(\$8,218.97)

**GENERAL CONTRACTOR CERTIFICATION UPON APPLICATION FOR PAYMENT**

OWNER:	<u>King County Housing Authority</u>	PAY REQUEST NUMBER:	<u>02</u>
GENERAL CONTRACTOR:	<u>CONTRACTOR NAME</u>	DATE: PERIOD FROM:	<u>4/1/2021</u>
PROJECT NAME:	<u>SITE NAME</u>	THROUGH:	<u>4/19/2021</u>
SCOPE OF WORK:	<u>PROJECT NAME</u>	CONTRACT NUMBER:	<u>CCxxxxx65</u>

1.	ORIGINAL CONTRACT AMOUNT:	\$	<u>583,767.96</u>
2.	APPROVED CHANGE ORDER(S):	\$	<u>(8,218.97)</u>
3.	CURRENT CONTRACT AMOUNT:	\$	<u>575,548.99</u>
4.	AMOUNT OF PREVIOUS CERTIFICATES FOR PAYMENT:	\$	<u>488,582.85</u>
5.	<b>AMOUNT OF CURRENT CERTIFICATE FOR PAYMENT REQUEST:</b>	<b>\$</b>	<b><u>58,188.69</u></b>

By submitting the accompanying Application for Payment, the Contractor certifies, agrees and warrants to the Owner as follows:

- The Contractor has made full payment to all laborers, subcontractors and suppliers of material and equipment whose charges were included in any prior Application for Payment, subject only to (a) retainage at the contract rate, and (b) the matters set forth below or on an attachment hereto.
- The Contractor knows of no one making a claim for payment other than those included in the current Application for Payment, who will be paid when the current Application for Payment is paid by Owner, except as noted below or on an attachment hereto.
- In consideration of payments made by Owner, the Contractor hereby waives and releases any and all claims and demands against Owner and the Project for all periods up to and including the period covered by this Application for Payment, subject only to (a) receipt of payment of the current Application, (b) applicable retainage, and (c) the matters set forth below or on an attachment hereto.

EXCEPTION(S) - DESCRIPTION:

AMOUNT:

GENERAL CONTRACTOR NAME:

CONTRACTOR NAME

BY AUTHORIZED SIGNER:

PRINT NAME

TITLE

DATE

**State of Washington  
County of King**

I certify that I know or have satisfactory evidence that \_\_\_\_\_ is the person who appeared before me, and said person acknowledged that (he/she) signed this instrument and acknowledged it to be (his/her) free and voluntary act for the uses and purposes mentioned in the instrument.

Signed before me on this \_\_\_\_\_ Day of \_\_\_\_\_

SEAL

Notary Public in and for the State of Washington

Residing at: \_\_\_\_\_

My Commission Expires: \_\_\_\_\_



## SUBSTITUTION REQUEST

PROJECT NAME: \_\_\_\_\_ DATE: \_\_\_\_\_  
A/E PROJECT NO.: \_\_\_\_\_ SUB. REQUEST NO.: \_\_\_\_\_  
FROM: \_\_\_\_\_ TO: \_\_\_\_\_  
RE: \_\_\_\_\_

SPECIFICATION TITLE: \_\_\_\_\_ DESCRIPTION: \_\_\_\_\_  
SECTION: \_\_\_\_\_ PAGE: \_\_\_\_\_ ARTICLE / PARAGRAPH: \_\_\_\_\_

PROPOSED SUBSTITUTION: \_\_\_\_\_  
MANUFACTURER: \_\_\_\_\_  
ADDRESS: \_\_\_\_\_ PHONE: \_\_\_\_\_  
TRADE NAME: \_\_\_\_\_ MODEL NO.: \_\_\_\_\_  
INSTALLER \_\_\_\_\_  
ADDRESS: \_\_\_\_\_ PHONE: \_\_\_\_\_

HISTORY:  New Product  2 - 5 years old  5 - 10 years old  More than 10 years old

Differences between proposed substitution and specified product: \_\_\_\_\_  
\_\_\_\_\_  
\_\_\_\_\_

Point-by-point comparative data attached - REQUIRED BY A/E

Reason for not providing specified item: \_\_\_\_\_  
\_\_\_\_\_

### SIMILAR INSTALLATION:

Project: \_\_\_\_\_ Architect: \_\_\_\_\_  
Address: \_\_\_\_\_ Owner: \_\_\_\_\_  
\_\_\_\_\_ Date Installed: \_\_\_\_\_

Proposed substitution affects other parts of the work:  No  Yes Explain: \_\_\_\_\_  
\_\_\_\_\_

Savings to Owner for accepting substitution \_\_\_\_\_ (\$ )

Proposed substitution changes Contract Time  No  Yes (If Yes):  Add  Deduct \_\_\_\_\_ days.

- If Contract Time is to be extended, a Change Order must be prepared.

Supporting Data Attached:  Drawings  Product Data  Samples  
 Tests  Reports  Other \_\_\_\_\_

The Undersigned certifies:

- Proposed substitution has been fully investigated and determined to be equal or superior in all respects to specified product.
- Same warranty will be furnished for proposed substitution as for specified product.
- Same maintenance service and source of replacement parts, as applicable is available.
- Proposed substitution will have no adverse effect on other trades and will not affect or delay progress schedule.
- Cost data as stated above is complete. Claims for additional costs related to accepted substitution which may subsequently become apparent are to be waived.
- Proposed substitution does not affect dimensions and functional clearances.
- Payment will be made for changes to building design, include A/E design, and construction costs caused by the substitution.
- Coordination, installation, and changes in the Work as necessary for accepted substitution will be complete in all respects.

Submitted by: \_\_\_\_\_

Signed by: \_\_\_\_\_

Firm: \_\_\_\_\_

Address: \_\_\_\_\_

Telephone: \_\_\_\_\_

Attachments: \_\_\_\_\_

A/E's Review and Action:

- Substitution approved – Make submittals in accordance with Specification Section
- Substitution approved as noted – make submittals in accordance with Specification Section
- Substitution rejected – Use specified materials
- Substitution Request received too late – Use specified materials

Signed by: \_\_\_\_\_ Date: \_\_\_\_\_



SOUTHEAST CORNER OF BUILDING 'A'



EAST ELEVATION OF BUILDING 'B'

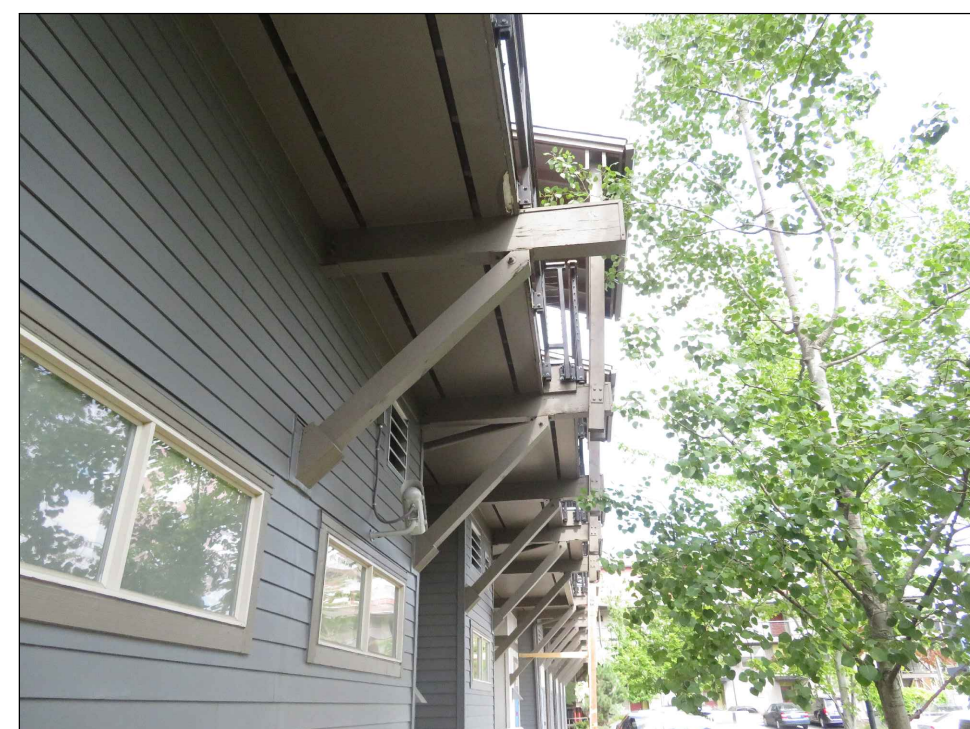

DECAYED WALKWAY FRAMING TO BE REPAIRED

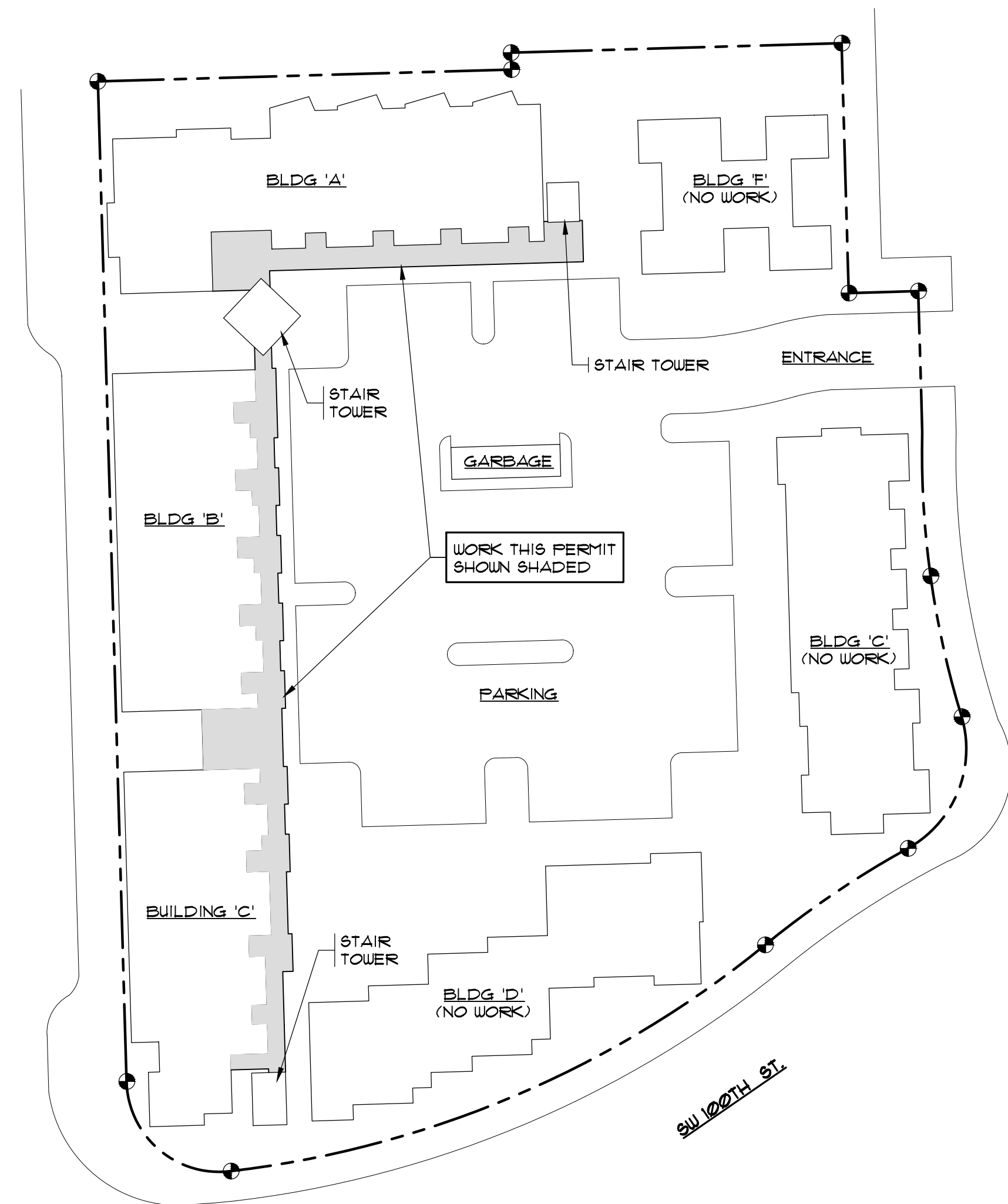

**SITE PLAN**  
SCALE: 1" = 30'-0"



NOTE:  
THE INFORMATION ON THIS SITE PLAN IS SCHEMATIC AND HAS BEEN DERIVED FROM THE SITE PLAN INFORMATION ON RECORD WITH KING COUNTY, AERIAL PHOTOGRAPHS AND SITE VISIT.

**DISCLAIMERS:**

**WATERPROOFING DISCLAIMER:**  
PACIFIC ENGINEERING TECHNOLOGIES, INC. HAS INCORPORATED INDUSTRY STANDARD FLASHING AND WEATHERPROOFING DETAILS IN THE REPAIR OF YOUR APARTMENT BUILDING. DUE TO THE COMPLEXITY AND UNIQUE DESIGN ELEMENTS OF THE SUBJECT BUILDING, PACIFIC ENGINEERING TECHNOLOGIES, INC. WILL MAKE NO EXPRESS OR IMPLIED WARRANTY OR GUARANTEE THAT THE SCOPE AND NATURE OF THE REPAIRS PROPOSED BY PACIFIC ENGINEERING TECHNOLOGIES, INC. AND SPECIFIED IN THE CONSTRUCTION PLANS AND DETAILS WILL COMPLETELY ELIMINATE ALL POSSIBLE FUTURE SOURCES OF STORM WATER INTRUSION OR STANDING WATER.

ADDITIONALLY, SINCE THE SCOPE OF REPAIR IS ISOLATED TO WORK AT THE SPECIFIC LOCATIONS, THE RECOMMENDED REPAIRS MAY NOT PREVENT MOISTURE INTRUSION INTO THE UNITS IF THE CAUSE IS RELATED TO OTHER SOURCES ABOVE OR BESIDE THE SPECIFIC REPAIR AREAS.

**MAINTENANCE:**  
NOTE TO BUILDING OWNER:  
THE SEVERE WEATHER CONDITIONS THAT ARE ENCOUNTERED DURING WINTER MONTHS IN THE PACIFIC NORTHWEST REQUIRE A DILIGENT ON-GOING MAINTENANCE PROGRAM FOR THE EXTERIOR WALKWAYS.

WALKWAYS MUST BE CLEANED ON A REGULAR BASIS IN ORDER THAT MOSS AND FUNGUS DOES NOT START TO GROW. FAILURE TO PROPERLY MAINTAIN WALKWAYS WILL LEAD TO PREMATURE FAILURE OF THE WATERPROOF MEMBRANE SURFACE.

BUILDING SEALANTS SHOULD ALSO BE EXAMINED ON AN ANNUAL BASIS. ANY SEALANTS THAT ARE FOUND NOT TO BE ADHERING PROPERLY SHOULD BE REPAIRED IMMEDIATELY.

DECK AND ROOF DRAINS MUST BE CLEANED ON A REGULAR BASIS TO PREVENT BLOCKAGE. BLOCKED DRAINS WILL ALLOW WATER TO BACK UP AND CONTRIBUTE TO WATER SEEPAGE INTO THE BUILDING.

EXTERIOR WOOD SHOULD BE EXAMINED ON A REGULAR BASIS TO MAINTAIN WATER RESISTANCE AND TO ENSURE MOSS AND FUNGUS DOES NOT START TO GROW.

**SCOPE OF WORK SUMMARY**

**TYPE: WALKWAY REPAIR**  
THE PURPOSE OF THESE DRAWINGS IS TO SHOW REPAIRS FOR THE WALKWAYS AT THE GREENBRIDGE APARTMENTS IN SEATTLE, WASHINGTON.

THE REPAIRS ARE IN ACCORDANCE WITH WSEBC CHAPTER 3 PROVISIONS FOR ALL COMPLIANCE METHODS, SECTION 3012 AND CHAPTER 4 REPAIRS.

THE SCOPE OF WORK CONSISTS OF THE FOLLOWING:  
• REPLACE THE WALKWAY WOOD MAIN SUPPORT BEAMS, POSTS AND KNEE BRACES WITH STEEL FRAMING AT BUILDINGS 'A', 'B', AND 'C'.  
• REPLACE DAMAGE WALKWAY WOOD BEAMS IN-KIND AT BUILDINGS 'A', 'B', AND 'C'.

THERE IS NO INCREASE IN THE EXISTING BUILDING(S) FOOTPRINT, SQUARE FOOTAGE OR HEIGHT.

**EXCLUSIONS:**  
NO REVIEW HAS BEEN MADE OF THE ADEQUACY OF THE EXISTING FRAMING MEMBERS.

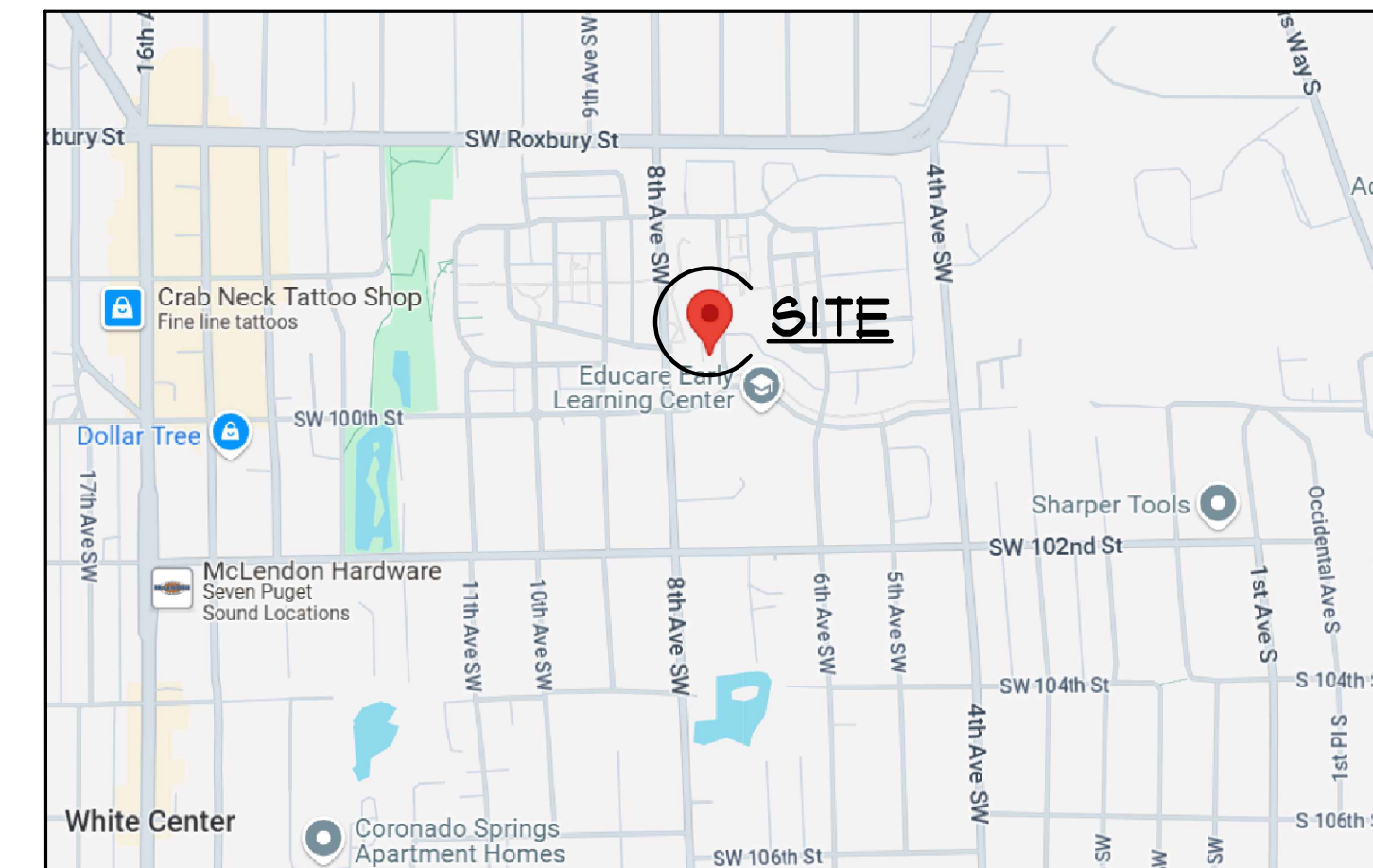

**VICINITY MAP**  
SCALE: N.T.S.

**ASSESSOR'S No.:** 289508-0160

**LEGAL DESCRIPTION:**

GREENBRIDGE MASTER PLAT  
PLAT BLOCK:  
PLAT LOT: 16

**BUILDING DATA:**

JURISDICTION: KING COUNTY  
CODES: 2021 WASHINGTON STATE EXISTING BUILDING CODE (WSEBC)  
2021 WASHINGTON STATE BUILDING CODE (WSBC)  
ZONING: R18  
OCCUPANCY: R-2 (APARTMENTS)  
M (RETAIL)  
CONSTRUCTION TYPE: V-A  
SPRINKLERED: YES  
NO. OF BUILDINGS: 6 (BUILDINGS A - F)  
WORK THIS PERMIT: BUILDINGS A, B AND C

**SHEET INDEX**

SHEET A1.0 SITE PLAN, VICINITY MAP AND PHOTOGRAPHS  
SHEET A1.1 NOTES  
SHEET A1.2 NOTES  
SHEET A2.0 WALKWAY PLANS  
SHEET A3.0 DETAILS  
SHEET A3.1 DETAILS  
SHEET S1.0 NOTES  
SHEET S2.0 WALKWAY FRAMING PLANS  
SHEET S3.0 SECTIONS

**RCW STATEMENT:**

THE "PROJECT" DOES NOT CLASSIFY AS A MULTITENANT BUILDING IN ACCORDANCE WITH RCW 64.55.010 (6.YVII) - A BUILDING WITH 12 OR FEWER UNITS THAT IS NO MORE THAN TWO STORIES. THEREFORE, THE BUILDING ENCLOSURE CERTIFICATIONS AND INSPECTIONS PER RCW 64.55.009 THROUGH 64.55.020 ARE NOT REQUIRED.

THE INFORMATION PRESENTED ON THESE DRAWINGS IS TO THE LEVEL OF DETAIL FOR CONSTRUCTION COST ESTIMATION ONLY, NOT FOR ACTUAL CONSTRUCTION

**PRELIMINARY**

ALL INFORMATION ON THIS DOCUMENT IS THE EXCLUSIVE PROPERTY OF PACIFIC ENGINEERING TECHNOLOGIES, INC. © COPYRIGHT 2026

Date	2/20/26
Revision	BID SET
No.	
Designed	G. MARCONDES
Drawn	V.H.N.
Checked	N.L.F.
Date	15 AUG, 2025
Approved	

**PACIFIC**  
ENGINEERING TECHNOLOGIES, INC.  
4444 Woodland Park Ave. N. - Suite 100 Seattle, Washington 98103-7499  
(206) 281-7500

Contents  
**SITE PLAN, VICINITY MAP AND PHOTOGRAPHS**

Project  
**GREENBRIDGE APARTMENTS BUILDINGS A, B AND C WALKWAY REPAIR**  
9915 11TH AVE. SEATTLE, WA

Sheet  
**A1.0**

Job No. 24200.00

**GENERAL NOTES:**

1. DO NOT SCALE DRAWINGS.
  2. REPETITIVE FEATURES MAY BE DRAWN OR CALLED OUT ONCE, BUT SHALL BE COMPLETELY PROVIDED AS IF DRAWN IN FULL.
  3. ALL WORKMANSHIP SHALL BE OF THE HIGHEST QUALITY AND SHALL BE IN ACCORDANCE WITH ALL MANUFACTURERS' SPECIFICATIONS, DIRECTIONS AND RECOMMENDATIONS. THE WORK SHALL ALSO BE IN STRICT CONFORMANCE WITH INDUSTRY STANDARDS AND COMPLY WITH SOUND ENGINEERING AND CONSTRUCTION PRACTICES. THE CONTRACTOR SHALL REPLACE PORTIONS OF THE INSTALLED WORK THAT DOES NOT MEET THESE REQUIREMENTS AT THEIR EXPENSE.
  4. ALL WORK SHALL BE PERFORMED IN ACCORDANCE WITH APPLICABLE FEDERAL, STATE AND LOCAL LAWS, AND IN ACCORDANCE WITH CURRENT CODE REQUIREMENTS.
  5. THE CONTRACTOR SHALL COORDINATE ALL REQUIRED LOCAL JURISDICTION INSPECTIONS AND SPECIAL INSPECTIONS. THE CONTRACTOR SHALL PROVIDE COPIES OF THE INSPECTION REPORTS TO PACIFIC ENGINEERING TECHNOLOGIES, INC. AND THE OWNER.
  6. ALL NEW AND/OR REPLACEMENT MATERIALS SHALL BE EQUAL OR BETTER IN KIND AS EXISTING MATERIALS.
  7. THE CONTRACTOR SHALL GUARANTEE ALL MATERIALS AND WORKMANSHIP FOR A PERIOD OF TWO (2) YEARS FROM THE DATE OF FINAL ACCEPTANCE BY OWNER.
  8. PLUMBING, MECHANICAL AND ELECTRICAL WORK (AS REQUIRED FOR REPAIR WORK) TO BE FILED UNDER SEPARATE PERMITS AND SHALL BE BIDDER DESIGNED. PLUMBING, MECHANICAL AND ELECTRICAL REPAIR DESIGN TO BE PERFORMED BY LICENSED AND QUALIFIED PLUMBING, MECHANICAL AND ELECTRICAL CONTRACTORS. ALL NEW MECHANICAL AND LIGHTING WORK SHALL CONFORM TO THE REQUIREMENTS OF THE WASHINGTON STATE ENERGY CODE.
  9. CONTACT THIS OFFICE AT (206) 281-1500 IF ANY ADDITIONAL DAMAGE IS FOUND OUTSIDE THIS SCOPE OF WORK DURING DEMOLITION OR ANY VARIATIONS TO THE SITE OR EXISTING BUILDING(S) ARE FOUND DURING THE CONSTRUCTION WORK.
- SITE CONDITIONS, SAFETY AND DEMOLITION:**
10. THE CONTRACTOR SHALL BE SOLELY RESPONSIBLE FOR THE CONDITIONS AT THE JOB SITE, INCLUDING THE SAFETY OF ALL PERSONS AT THE JOB SITE DURING THE PERFORMANCE OF THE WORK. THIS REQUIREMENT SHALL APPLY CONTINUOUSLY AND NOT BE LIMITED TO NORMAL WORKING HOURS.
  11. THE CONTRACTOR SHALL PROVIDE ACCEPTABLE SAFETY AND SECURITY MEASURES AND SHALL MAINTAIN SAFETY AND SECURITY AT THE JOB SITE DURING THE ENTIRE COURSE OF THE PROJECT.
  12. THE CONTRACTOR SHALL PROVIDE TEMPORARY BARRICADES AND OTHER FORMS OF PROTECTION TO PROTECT THE PUBLIC FROM INJURY DUE TO DEMOLITION AND REPAIR WORK. BARRICADES ARE TO REMAIN IN PLACE AFTER DEMOLITION WORK HAS BEEN COMPLETED AND THROUGHOUT THE DURATION OF THE WORK.
  13. THE CONTRACTOR SHALL REASONABLY SECURE SCAFFOLDING, WORK AREAS, BUILDING MATERIALS AND TOOLS FROM ACCESS TO THE PUBLIC AT ALL TIMES.
  14. THE REQUIRED AND/OR IMPLIED DUTY OF PACIFIC ENGINEERING TECHNOLOGIES, INC. TO CONDUCT CONSTRUCTION REVIEW OF THE CONTRACTOR'S PERFORMANCE DOES NOT, AND IS NOT INTENDED TO, INCLUDE REVIEW OF THE ADEQUACY OF THE CONTRACTOR'S SAFETY MEASURES IN, ON, OR NEAR THE CONSTRUCTION SITE.
  15. THE CONTRACTOR AND THE SUB-CONTRACTORS SHALL VISIT THE SITE TO REVIEW THE EXISTING SITE, BUILDING CONDITIONS, AND FEATURES, INCLUDING BUT NOT LIMITED TO: GRADES, DIMENSIONS, ACCESS TO THE WORK, POWER ACCESS, STAGING, REFUSE DISPOSAL, MATERIAL STORAGE, ETC.
  16. BEFORE WORK BEGINS, LOCATE ALL UNDERGROUND UTILITIES BY CONTACTING "CALL BEFORE YOU DIG" AT 1-800-424-5555 OR 811.
  17. A PRECONSTRUCTION MEETING WILL BE HELD PRIOR TO THE START OF THE PROJECT TO REVIEW GENERAL CONDITIONS, STAGING, SEQUENCING, ETC.
  18. ALL WORK SHALL BE PERFORMED DURING NORMAL BUSINESS HOURS DEFINED AS 8:00 AM TO 5:00 PM, MONDAY THROUGH FRIDAY, UNLESS OTHERWISE AGREED TO BY THE CONTRACTOR AND THE OWNER IN ADVANCE OR IF LOCAL JURISDICTIONAL REQUIREMENTS DICTATE DIFFERENTLY. THE STAGING OF THE WORK MAY COMMENCE 30 MINUTES PRIOR TO THE AGREED EARLIEST STARTING TIME.
  19. THE CONTRACTOR SHALL COORDINATE WITH THE OWNER FOR A DESIGNATED AREA WITHIN THE SITE TO BE USED FOR THE STORAGE OF MATERIALS, EQUIPMENT AND TEMPORARY CONSTRUCTION OFFICE BEFORE COMMENCING WITH THE WORK. THE SECURITY OF THE MATERIALS, EQUIPMENT AND TEMPORARY CONSTRUCTION OFFICE STORED ON-SITE IS THE RESPONSIBILITY OF THE CONTRACTOR.
  20. THE CONTRACTOR SHALL COORDINATE WITH THE OWNER FOR SCHEDULING ACCESS INTO UNITS, IF REQUIRED. IN UNITS THE CONTRACTOR ENTERS TO PERFORM REPAIRS, THE CONTRACTOR SHALL PHOTOGRAPH THE EXISTING CONDITIONS PRIOR TO REPAIRS SO AS TO AID IN RESOLVING ANY POSSIBLE CLAIMS THE OWNER MAY HAVE ABOUT DAMAGE TO INTERIORS FROM THE REPAIR WORK.
  21. IT IS INTENDED TO KEEP THE BUILDINGS OCCUPIED DURING THE PERFORMANCE OF THE WORK. MAINTAIN OR PROVIDE ACCESS TO ENTRY DOORS AND A CLEAR PATH TO DRIVEWAYS, SIDEWALKS AND ENTRY WALKWAYS TO NOT ADVERSELY IMPACT THE TENANTS AND GUESTS ENTERING AND LEAVING THE BUILDING(S) AND PREMISES AT ALL TIMES EXCEPT AS PRE-ARRANGED WITH OWNER. MAINTAIN ALL BUILDING EXITS.
  22. THE WORK SHALL NOT BLOCK INGRESS OR EGRESS FROM THE SITE AT ANY TIME. THE CONTRACTOR'S VEHICLES AND EQUIPMENT SHALL NOT BLOCK THE MARKED FIRE LANES OR DRIVEWAYS AND NOT UTILIZE ANY RESERVED PARKING SPACES WITHOUT OWNER'S PERMISSION.
  23. THE CONTRACTOR SHALL PROVIDE PORTABLE RESTROOM FACILITIES FOR WORKERS.
  24. THE CONTRACTOR SHALL PROVIDE ITS OWN DUMPSTER FOR CONSTRUCTION DEBRIS.
  25. THE CONTRACTOR SHALL PROVIDE HEAT AS NECESSARY TO COMPLETE THE WORK.
  26. THE CONTRACTOR SHALL BE RESPONSIBLE FOR DEMOLITION, TEMPORARY BRACING, METHODS, TECHNIQUES, SEQUENCES AND PROCEDURES IN CONNECTION WITH THE WORK.
  27. THE CONTRACTOR SHALL PROVIDE TEMPORARY BRACING OR SUPPORT TO PREVENT MOVEMENT OR SETTLEMENT OF STRUCTURE AS NEEDED IN AREAS BEING REPAIRED.
  28. PROVIDE SCAFFOLDING AND TEMPORARY WEATHER PROTECTION FOR AREAS OF THE BUILDING EXPOSED DURING CONSTRUCTION AS NECESSARY TO ACCOMPLISH THE REPAIR WORK SUFFICIENTLY AND TO PREVENT WATER DAMAGE FROM OCCURRING AS THE WORK PROGRESSES. ANY WATER DAMAGE TO THESE AREAS RESULTING DURING REPAIRS IS TO BE REPAIRED AT NO COST TO OWNER.
  29. PROTECT LANDSCAPING, DRAINAGE AND IRRIGATION SYSTEMS AS REQUIRED TO ACCOMPLISH THE WORK OR REMOVE AND REPLACE LANDSCAPING, DRAINAGE AND IRRIGATION SYSTEMS, WHICHEVER IS MORE COST EFFECTIVE. FOLLOWING THE WORK, THE IRRIGATION AND DRAINAGE SYSTEMS SHALL BE TESTED TO VERIFY THAT THEY ARE FUNCTIONING PROPERLY. ALL DAMAGED ITEMS SHALL BE REPLACED AT NO COST TO THE OWNER.
  30. PROPERLY PROTECT OR CAP ALL UTILITIES THAT MIGHT BE DISTURBED DUE TO DEMOLITION ACTIVITY.
  31. PROTECT EXISTING FINISHES, FIXTURES, EQUIPMENT, ETC. THAT ARE TO REMAIN FROM DAMAGE DURING CONSTRUCTION.
  32. THE CONTRACTOR IS TO LAY DOWN TEMPORARY COVER OF FLOOR TILE, CARPETS, FINISHES, ETC. FOR ANY WORK TO BE COMPLETED WITHIN THE UNITS.

**GENERAL NOTES (CONT.):**

33. PRIOR TO GENERAL/SELECTIVE DEMOLITION, THE GENERAL CONTRACTOR SHALL OBTAIN THE PERMISSION OF THE OWNER TO TEST WHETHER HAZARDOUS WASTES OR ASBESTOS IS PRESENT IN DEMOLITION DEBRIS. SHOULD HAZARDOUS MATERIALS OR ASBESTOS BE FOUND IN DEMOLITION DEBRIS, THE CONTRACTOR SHALL LEGALLY CONTAIN SUCH MATERIAL AND DISPOSE OF OFF SITE AT AN APPROVED DUMP SITE AFTER OBTAINING THE OWNER'S PERMISSION TO DO SO. THE COST OF RETAINING A QUALIFIED TESTING FIRM TO OBTAIN SAMPLES AND TEST FOR HAZARDOUS MATERIALS SHALL BE THE RESPONSIBILITY OF THE CONTRACTOR.
  34. COORDINATE ALL DEMOLITION ACTIVITIES WITH THE OWNER.
  35. THE CONTRACTOR SHALL TRANSPORT AND DISCARD IN A LEGAL MANNER ALL CONSTRUCTION DEBRIS AND REMOVED ITEMS NOT INTENDED FOR REUSE.
  36. INSPECT CONCEALED SPACES UNCOVERED DURING THE DEMOLITION PHASE FOR ADDITIONAL DAMAGE.
  37. REMOVE AND REPLACE ALL MOISTURE DAMAGED FINISHES INCLUDING DAMAGED THERMAL AND SOUND INSULATION.
  38. PRIOR TO COMPLETION OF DEMOLITION, THE CONTRACTOR SHALL REMOVE AND/OR PHOTOGRAPHICALLY DOCUMENT REPRESENTATIVE SAMPLES OF EXTERIOR TRIM, SIDING, ROOFING, INTERIOR TRIM, DOORS, ALL DOOR HARDWARE, WALL BASE TRIM, WALL COVERINGS, WINDOW COVERINGS, KITCHEN AND BATH ACCESSORIES, APPLIANCES, ETC. AS A GUIDE FOR REPLACEMENT OF LIKE-KIND MATERIALS.
  39. THE CONTRACTOR IS TO LEAVE THE SITE BROOM CLEAN FROM CONSTRUCTION RELATED DEBRIS AFTER DEMOLITION WORK IS COMPLETE, AT THE END OF EACH DAY AND AT THE END OF THE PROJECT.
- CONSTRUCTION:**
40. SUBCONTRACTORS SHALL HAVE A MINIMUM OF TEN YEARS OF EXPERIENCE INSTALLING THEIR RESPECTIVE PRODUCTS AND SHALL BE MANUFACTURER APPROVED INSTALLERS OF THOSE PRODUCTS.
  41. ALL SUCH PRODUCTS AND MATERIALS SHALL BE INSTALLED IN ACCORDANCE WITH THE MANUFACTURER'S RECOMMENDATIONS AND INSTALLATION INSTRUCTIONS, INDUSTRY STANDARDS AND CODE REQUIREMENTS. THE CONTRACTOR SHALL SUBMIT TO PACIFIC ENGINEERING TECHNOLOGIES, INC. A COPY OF THE INSTALLATION INSTRUCTIONS AND RELATED INSTALLATION STANDARDS AND REQUIREMENTS FOR REVIEW AND APPROVAL AND THE CONTRACTOR SHALL KEEP A SET OF THESE INSTRUCTIONS ON THE SITE DURING REPAIRS RELATING TO THAT WORK.
  42. PROVIDE WEATHER-RESISTIVE / AIR BARRIER BEHIND WALL CLADDING IN ACCORDANCE WITH USBC 1402.2 AND 1402.5 AND THE WASHINGTON STATE COMMERCIAL C402.5.1. WEATHER-RESISTIVE / AIR BARRIER SHALL BE CONTINUOUS AND ALL JOINTS SHALL BE TAPED OR SEALED IN ACCORDANCE WITH THE MANUFACTURER'S RECOMMENDATIONS.
  43. PROVIDE FLASHINGS FOR EXTERIOR BUILDING COMPONENTS IN ACCORDANCE WITH USBC CHAPTER 1404.4.
  44. INSTALL ROOFING COMPONENTS IN ACCORDANCE WITH USBC CHAPTER 15.
  45. THE CONTRACTOR SHALL VERIFY THAT ALL WATERPROOFING COMPONENTS ARE COMPATIBLE WITH EACH OTHER, I.E. SEALANTS AND BACKER ROD, SEALANTS, AND SELF ADHESIVE (FEEL 'N' STICK) MEMBRANE, ETC.
  46. THE CONTRACTOR SHALL SUBMIT MANUFACTURER'S PRODUCT DATA, MOCK-UP SAMPLES, SHOP DRAWINGS AND INSTALLATION INSTRUCTIONS FOR ALL PRODUCTS (SUCH AS: WINDOWS, SEALANTS, SHEET METAL FLASHINGS, SELF ADHESIVE MEMBRANES AND WATERPROOF MEMBRANES, ETC.) TO PACIFIC ENGINEERING TECHNOLOGIES, INC. FOR REVIEW PRIOR TO PRODUCT INSTALLATION.
  47. THE CONTRACTOR IS TO PROVIDE PACIFIC ENGINEERING TECHNOLOGIES, INC. WITH ACCESS TO REVIEW THE INSTALLATION OF THE NEW WEATHER-RESISTIVE BARRIER AND FLASHINGS PRIOR TO BEING COVERED BY THE NEW SIDING SYSTEM. THE CONTRACTOR IS TO PROVIDE A MINIMUM OF SEVENTY-TWO (72) HOURS NOTICE (EXCLUDING WEEKENDS) PRIOR TO WHEN THE CONTRACTOR WANTS REVIEW PERFORMED. THE CONTRACTOR IS TO MODIFY ANY CONDITIONS WITH THE INSTALLATION OF THE WEATHER-RESISTIVE BARRIER AND FLASHING SYSTEM AS DIRECTED BY PACIFIC ENGINEERING TECHNOLOGIES, INC. THAT DOES NOT COMPLY WITH THE REPAIR DRAWINGS. PACIFIC ENGINEERING TECHNOLOGIES, INC. MAY REQUIRE THAT THE SIDING BE REMOVED AND REPLACED AT NO COST TO THE OWNER IF PACIFIC ENGINEERING TECHNOLOGIES, INC. IS NOT ALLOWED TO REVIEW THE INSTALLATION OF THE WEATHER-RESISTIVE BARRIER AND FLASHINGS DUE TO INSUFFICIENT NOTIFICATION.
  48. NEW THERMAL INSULATION MUST COMPLY WITH THE CURRENT EDITION OF THE WASHINGTON STATE ENERGY CODE.
  49. PROVIDE MINIMUM R-3 PER INCH FOR EXISTING EXPOSED CEILING, WALL, OR FLOOR CAVITIES WASHINGTON STATE ENERGY CODE C503.1 EXCEPTION 3.
  50. ALL VENTILATION OPENINGS SHALL BE SCREENED EXCEPT DRYER VENTS. ALL VENT OPENINGS SHALL HAVE LOUVERS.
  51. THE CONTRACTOR SHALL REPAIR INTERIOR DISTRESS, SUCH AS, BUT NOT LIMITED TO NAIL POPS RESULTING FROM THE CONSTRUCTION WORK AND REPAIR THE INSIDE OF THE UNITS IF REQUIRED. ALL REPAIRS SHALL MATCH EXISTING AS CLOSE AS POSSIBLE. PROVIDE AN ALLOWANCE FOR EACH UNIT IN THE BID.
  52. THE CONTRACTOR SHALL BE RESPONSIBLE FOR PERFORMING ALL TESTING AND RECERTIFICATION OF THE EXISTING FIRE SPRINKLER AND FIRE ALARM SYSTEMS IF REQUIRED BY THE FIRE MARSHAL OR BUILDING DEPARTMENT.
  53. MECHANICAL EXHAUST DUCTS WHICH PENETRATE FIRE RESISTIVE WALL, FLOOR/CEILING OR ROOF/CEILING ASSEMBLIES SHALL BE FIRE DAMPERED OR LOCATED WITHIN FIRE RESISTIVE SHAFTS IN ACCORDANCE WITH USBC SECTION 711.
  54. PROVIDE FIREBLOCKING AND DRAFTSTOPPING AT INTERCONNECTIONS BETWEEN CONCEALED SPACES (SUCH AS SOFFITS, DROPPED CEILINGS, ATTICS, WALL CAVITIES, ETC.) AT THE CEILING AND FLOOR LEVELS AND HORIZONTALLY AT 10' INTERVALS IN ACCORDANCE WITH USBC SECTION 718.
  55. HOLES FOR WIRING AND PLUMBING PENETRATIONS THAT PASS THROUGH FIRE-RESISTANCE RATED ASSEMBLIES ARE TO BE SEALED WITH A FIRE RATED EXPANDING FOAM OR SEALANT. THE FOAM OR SEALANT SHALL BE IN ACCORDANCE WITH ASTM E 814 OR UL 1479 WITH AN F AND T RATING NOT LESS THAN THE ASSEMBLY RATING IN ACCORDANCE WITH USBC SECTION 714.4 AND 714.5.
  56. ALL NEW WOOD PLATES, NAILING STRIPS, AND LEDGERS IN CONTACT WITH CONCRETE OR EXPOSED TO THE WEATHER SHALL BE PRESSURE PRESERVATIVE TREATED. CUT ENDS, ETC. SHALL BE PAINTED WITH (2) COATS OF WOOD PRESERVATIVE PAINT.
  57. PROVIDE DIFFERENTIAL METAL PROTECTION TO PREVENT GALVANIC ACTION WHERE OCCURS.
  58. UPON COMPLETION OF ALL REPAIR WORK, THE OWNER, PACIFIC ENGINEERING TECHNOLOGIES, INC. AND CONTRACTOR WILL DEVELOP A "PUNCH LIST" OF WORK ITEMS TO BE COMPLETED AS PART OF THE PROJECT CLOSE-OUT. ALL ITEMS ON THE PUNCH LIST SHALL BE CORRECTED/REPAIRED BEFORE THE OWNER'S FINAL ACCEPTANCE OF THE WORK.
  59. UPON FINAL ACCEPTANCE OF THE WORK, CONTRACTOR SHALL SUBMIT AN OPERATION AND MAINTENANCE MANUAL AND ALL WARRANTIES TO THE HOMEOWNER'S ASSOCIATION.

Date	2/20/26
Revision	BID SET
No.	
Designed	G. MARCONDES
Drawn	V.H.N.
Checked	N.L.F.
Date	15 AUG, 2025
Approved	



Project: GREENBRIDGE APARTMENTS BUILDINGS A, B AND C WALKWAY REPAIR 9915 1TH AVE. SEATTLE, WA

Contents: NOTES

Sheet: A1.1

Job No. 24200.00

THE INFORMATION PRESENTED ON THESE DRAWINGS IS TO THE LEVEL OF DETAIL FOR CONSTRUCTION COST ESTIMATION ONLY, NOT FOR ACTUAL CONSTRUCTION

**PRELIMINARY**

ALL INFORMATION ON THIS DOCUMENT IS THE EXCLUSIVE PROPERTY OF PACIFIC ENGINEERING TECHNOLOGIES, INC. © COPYRIGHT 2026

**MATERIAL SPECIFICATIONS:**

**MATERIAL SPECIFICATIONS:**  
 THE MATERIAL SPECIFICATIONS ARE PRESENTED IN A SHORT FORM FORMAT. THE CONTRACTOR AND/OR SUBCONTRACTOR(S) SHALL INSTALL THE PRODUCTS IN ACCORDANCE WITH THE FOLLOWING CURRENT EDITION OF INDUSTRY STANDARDS AND CODES IN NO PARTICULAR ORDER:  
 A. REVISED CODE OF WASHINGTON (RCW)  
 B. WASHINGTON STATE BUILDING CODE (WSBC)  
 C. NATIONAL ROOFING CONTRACTORS ASSOCIATION (NRCA)  
 D. SHEET METAL AND AIR CONDITIONING NATIONAL ASSOCIATION (SMACNA)  
 E. MANUFACTURER'S PRODUCT INSTALLATION RECOMMENDATIONS  
 F. THESE REPAIR DOCUMENTS

**SOFFIT GYPSUM SHEATHING BOARD:**  
 A. SHALL BE GEORGIA-PACIFIC DENSGLASS SHEATHING  
 B. SHALL BE EXTERIOR RATED 5/8" THICK FIBERGLASS-FACED TYPE 'X' SHEATHING  
 C. INSTALL THE GSB WITH GALVANIZED 2d ROOFING NAILS (1 3/4" LONG) AT 4" ON-CENTER AT VERTICAL JOINTS, INTERMEDIATE STUDS AND TOP AND BOTTOM FLATES  
 D. REPLACE FULL SECTIONS OF SHEATHING WHERE POSSIBLE. BLOCK ALL EDGES.

**WOOD PRESERVATIVE:**  
 ALL LUMBER IN CONTACT WITH EARTH OR CONCRETE SHALL BE PRESSURE TREATED IN ACCORDANCE WITH AWP A STANDARD C2 WITH AMMONIACAL COPPER ZINC ARSENATE (ACZA) TO 0.25 PCF RETENTION WITH AN ASSAY ZONE 0.4" IN DEPTH. PAINT ALL SCARS, CUTS AND DRILL HOLES WITH TWO COATS OF COPPER NAPHTHATE.

**METAL FLASHINGS:**  
 METAL FLASHINGS SHALL MEET THE FOLLOWING SPECIFICATIONS:  
 • METAL FLASHINGS ARE TO BE GALVANIZED G90 (UNO).  
 • METAL FLASHINGS SHALL BE MINIMUM 24 GAUGE (UNO).  
 • FLASHINGS IN DIRECT CONTACT WITH CONCRETE OR BELOW GRADE ARE TO BE STAINLESS STEEL (UNO).  
 • VISIBLE METAL FLASHINGS SHALL BE PREFINISHED (KYNAR 500 OR EQUIVALENT). COLORS SHALL BE SUBMITTED TO AND APPROVED BY ARCHITECT.  
 • JOINTS SHALL BE SOLDERED.  
 • METAL FLASHINGS ARE TO BE ONE CONTINUOUS PIECE AS LONG AS POSSIBLE TO MINIMIZE JOINTS.  
 • HEM EXPOSED EDGES.  
 • FLASHINGS TO HAVE MINIMUM 6" VERTICAL LEGS AND 4" HORIZONTAL LEGS (UNO).  
 • FLASHING FLANGES SHALL EXTEND A MINIMUM 6" BEYOND INSIDE AND OUTSIDE CORNERS AND OPENINGS (I.E. THROUGH WALL SCUPPERS).  
 • SET FLASHINGS IN SEALANT (REFERENCE SEALANTS SECTION).  
 • LAPS/SPICES WITH OTHER FLASHINGS ARE TO BE 6" MINIMUM (UNO) SET IN (3) 3/8" CONT. BEADS OF SEALANT PARALLEL TO EDGE OF FLASHING, (REFERENCE SEALANTS SECTION).  
 • PROPERLY INTEGRATE METAL FLASHINGS WITH ADJACENT WEATHER-RESISTIVE BARRIER AND FLASHING ASSEMBLIES IN WEATHER BOARD FASHION WITH 6" MINIMUM VERTICAL LAPS/SPICES AND 3" MINIMUM HORIZONTAL LAPS/SPICES.  
 • PROVIDE SEPARATION (SUCH AS A LAYER OF COMPATIBLE SAF OR WRB) BETWEEN DISSIMILAR METALS TO PREVENT GALVANIC ACTION (CORROSION).  
 • OVER-BREAK OR UNDER-BREAK METAL FLASHINGS TO PROVIDE A TIGHT FIT AGAINST THE SUBSTRATE.  
 • METAL FLASHINGS SHALL HAVE CONTINUOUS SUPPORT AND POSITIVE ATTACHMENT TO THE BUILDING.  
 • FLASHINGS SHALL BE FABRICATED TO SLOPE AWAY FROM THE BUILDING OR TOWARDS THE ROOF.  
 • FABRICATION AND INSTALLATION OF METAL FLASHINGS IS TO TAKE INTO ACCOUNT EXPANSION AND CONTRACTION TO AVOID BUCKLING.  
 • THE CONTRACTOR SHALL PROVIDE MOCK-UPS OF METAL FLASHINGS FOR APPROVAL PRIOR TO FINAL FABRICATION AND INSTALLATION.  
 • CUT AND FOLDED LAP SPICES ARE NOT ACCEPTABLE.  
 • METAL FLASHINGS SHALL BE IN ACCORDANCE WITH SHEET METAL AND AIR CONDITIONING CONTRACTORS NATIONAL ASSOCIATION (SMACNA) ARCHITECTURAL SHEET METAL MANUAL.

**WATERPROOFING ACCESSORIES:**  
 • POLYCOAT 150 (MANUFACTURED BY POLYCOAT)  
 • SURE-TO-LEAK-STOP (MANUFACTURED BY POLYURETHANE, PEDESTRIAN WATERPROOFING DECK MEMBRANE COATING SYSTEM).  
 • CONTRACTOR SHALL USE ALL ASSOCIATED MANUFACTURER RECOMMENDED ACCESSORIES AND PRODUCTS SUCH AS SEALANTS, REINFORCING MESH, SILICA SAND, PRIMER, ETC.  
 • INSTALL WATERPROOF MEMBRANE SO THAT A UNIFORM AND CONSISTENT SURFACE IS PROVIDED WITH NO VISIBLE SEAMS OR TRANSITIONS.  
 • CONTRACTOR SHALL PERFORM AN ADHESION TEST TO ALL UNIQUE SURFACES PRIOR TO APPLICATION OF THE WATERPROOF MEMBRANE SYSTEM.  
 THE CONTRACTOR SHALL SUBMIT A WRITTEN REPORT STATING THE PREPARATION METHOD USED AND THE ADHESION TEST RESULTS TO PACIFIC ENGINEERING TECHNOLOGIES, INC. FOR REVIEW PRIOR TO APPLICATION OF THE WATERPROOF MEMBRANE SYSTEM.  
 • THE COLOR OF THE DECK MEMBRANE SHALL MATCH THE EXIST.  
 • OWNER TO APPROVE COLOR SELECTION PRIOR TO PURCHASE AND INSTALLATION.

**SELF ADHESIVE FLASHING (SAF):**  
 • HENRY FORTIFIBER FORTIFLASH BUTYL 30mil.  
 USE A MANUFACTURER RECOMMENDED PRIMER FOR INSTALLATION OVER OSB OR GYPSUM SHEATHING.

**FLUID APPLIED FLASHING:**  
 A. SHALL BE PROSOCCO / R-GUARD, LIQUID FLASHING MEMBRANE SYSTEM. THE SYSTEM CONSISTS OF THE FOLLOWING:  
 • JOINT AND SEAM FILLER  
 • FASTFLASH  
 • POROUSPREP  
 B. THE FLUID FLASHING MEMBRANE IS TO BE INSTALLED SUCH THAT THE UNDERLYING SUBSTRATE THAT THE FLUID FLASHING IS APPLIED TO, IS NOT VISIBLE AFTER APPLICATION (APPROX. 35 MIL. THICKNESS).  
 C. WHERE FLUID FLASHING MEMBRANE IS TO BE INTEGRATED WITH THE WRB, VERIFY THE ADHESION COMPATIBILITY WITH THE MANUFACTURER PRIOR TO PROCEEDING.  
 D. USE POROUSPREP ON EXPOSED EDGES OF GYPSUM SHEATHING PRIOR TO APPLICATION.

**WEATHER RESISTIVE BARRIER (WRB):**  
 THE WATER-RESISTIVE / AIR BARRIER SYSTEM SHALL MEET THE FOLLOWING SPECIFICATIONS:  
 • FORTIFIBER WEATHERSMART COMMERCIAL WRAP MANUFACTURED BY HENRY  
 a. THE SYSTEM IS TO INCLUDE ALL, ASSOCIATED ACCESSORIES AND ATTACHMENTS.  
 b. SEAL ALL LAPS AND SEAMS WITH MANUFACTURER'S PROVIDED TAPE AND/OR DOW CORNING 790 SILICONE WEATHER BARRIER SEALANT IN ACCORDANCE WITH MANUFACTURER'S RECOMMENDATIONS.  
 c. INSTALL IN ACCORDANCE WITH MANUFACTURER'S RECOMMENDATIONS.  
 • OR APPROVED EQUIVALENT. CONTRACTOR SHALL PROVIDE ALTERNATE IN BID DOCUMENTS

**MATERIAL SPECIFICATIONS (CONT.):**

**FIBER CEMENT SIDING:**  
 SHALL BE JAMES HARDIE FIBER-CEMENT H210 SIDING.  
 • HARDIE PANEL 5/16" SMOOTH PANELS.  
 A. ALL CUT EDGES OF THE SIDING PANELS SHALL BE PRIMED PRIOR TO INSTALLATION.  
 B. ATTACH SIDING TO MINIMUM 3/8" THICK PRESSURE TREATED FURRING STRIPS AND THE STRUCTURE IN ACCORDANCE WITH THE MANUFACTURER'S RECOMMENDATIONS. THE FASTENING PATTERN SHOULD BE DESIGNED FOR THE FOLLOWING CONDITIONS:  
 • BUILDING HEIGHT: 40'  
 • WIND SPEED: 110 MPH  
 • EXPOSURE: D  
 SUBMIT FASTENING PATTERN AND FASTENERS TO PACIFIC ENGINEERING TECHNOLOGIES, INC. FOR REVIEW AND APPROVAL PRIOR TO INSTALLATION.

**BACKER ROD:**  
 SOF-ROD BACKER ROD, MANUFACTURED BY NOMACO

THE DIAMETER OR WIDTH SHALL BE AS RECOMMENDED BY MANUFACTURER FOR THE SPECIFIC OPENING TO RECEIVE SEALANT. WHERE BACKER RODS ARE TO TURN 90 DEGREE CORNERS THE BACKER ROD SHALL TERMINATE AT CORNER AND A NEW PIECE OF BACKER ROD WILL CONTINUE IN THE NEXT DIRECTION.  
 ALLOW THE BACKER ROD TO REST (APPROXIMATELY 30 MINUTES) BEFORE APPLYING SEALANT.  
 IF BACKER ROD CAN NOT BE USED IN A PARTICULAR SITUATION, BOND BREAKING TAPE SHALL BE USED TO PREVENT THREE-SIDED ADHESION. INSTALL BACKER RODS PER MANUFACTURER'S RECOMMENDATIONS.

**SEALANTS:**  
**EXPOSED EXTERIOR SEALANT JOINTS:**  
 • SIKAFLEX HY100

SEALANT COLOR SHALL BE SIMILAR TO FINAL PAINTED COLOR (GRAY OR BLACK).

**WRB SEALANT:**  
 SHALL BE COMPATIBLE WITH AND ABLE TO ADHERE TO THE WRB.  
 APPROVED SEALANTS:  
 • HENRY MOISTOP SEALANT

**TRIM BOARDS:**  
 SHALL BE JAMES HARDIE TRIM BOARDS. ALL CUT ENDS SHALL BE PRIMED PRIOR TO INSTALLATION. INSTALL IN ACCORDANCE WITH MANUFACTURER'S RECOMMENDATIONS. SHIM AS REQUIRED TO BE FLUSH WITH ADJACENT TRIM.

**GUARDRAIL COMPOSITE TOP RAIL:**  
 2x3 FIBER REINFORCED LUMBER MANUFACTURED BY TANGET MATERIALS.

**PAINT (TRIM AND SIDING):**  
 SHALL BE SHERWIN-WILLIAMS SUPERPAINT. PROVIDE MANUFACTURER 10 YEAR WARRANTY. CONTRACTOR TO PROVIDE PRODUCT DATA AND 1" BY 1" COLOR SAMPLES FOR REVIEW AND APPROVAL BY PACIFIC ENGINEERING TECHNOLOGIES, INC AND THE OWNER PRIOR TO PURCHASE AND INSTALLATION.

**PAINT (ZINC RICH FOR METAL CORROSION):**  
 SHERWIN WILLIAMS ZINC CLAD 5

**PAINT (INSTALLED/EXISTING METAL AND STEEL):**  
 SHERWIN WILLIAMS PRO INDUSTRIAL DTM

**GENERAL NOTES:**  
 • CONTRACTOR SHALL VERIFY ALL PRODUCTS AND MATERIALS ARE COMPATIBLE WITH EACH OTHER PRIOR TO INSTALLATION.  
 • CONTRACTOR MAY SUBSTITUTE MATERIALS WITH SIMILAR QUALITY MATERIALS. SUBSTITUTED MATERIALS SHALL BE APPROVED BY ENGINEER AND WATERPROOFING DESIGNER PRIOR TO PURCHASE AND INSTALLATION.  
 • ALL PRODUCTS AND MATERIAL SAMPLES, INSTALLATION RECOMMENDATIONS AND SPECIFICATIONS SHALL BE SUBMITTED TO PACIFIC ENGINEERING TECHNOLOGIES, INC. FOR APPROVAL PRIOR TO PURCHASE AND INSTALLATION.  
 • COLORS ARE TO MATCH THE PRE-EXISTING BUILDING COLOR SCHEME. ANY PROPOSED COLOR CHANGES ARE TO BE APPROVED BY THE OWNER PRIOR TO PURCHASE AND INSTALLATION.  
 • CONTRACTOR IS TO FOLLOW MANUFACTURER'S APPLICATION RECOMMENDATIONS FOR COLD WEATHER WHEN TEMPERATURES ARE BELOW 40°. CONTRACTOR IS TO PERFORM AN ADHESION TEST FOR ALL QUESTIONABLE SUBSTRATES PRIOR TO FINAL INSTALLATION.

For bidding purposes, use Rhino Lining Extreme for base bid as noted in specifications.

THE INFORMATION PRESENTED ON THESE DRAWINGS IS TO THE LEVEL OF DETAIL FOR CONSTRUCTION COST ESTIMATION ONLY, NOT FOR ACTUAL CONSTRUCTION

**PRELIMINARY**

ALL INFORMATION ON THIS DOCUMENT IS THE EXCLUSIVE PROPERTY OF PACIFIC ENGINEERING TECHNOLOGIES, INC. © COPYRIGHT 2026

Date	2/20/26
Revision	BID SET
No.	
Designed	G. MAIRCONDES
Drawn	V.H.N.
Checked	N.L.F.
Date	15 AUG, 2025
Approved	



4444 Woodland Park Ave. N. - Suite 100 Seattle, Washington 98103-7499  
 (206) 281-7500

Project: GREENBRIDGE APARTMENTS BUILDINGS A, B AND C WALKWAY REPAIR 9915 1TH AVE. SEATTLE, WA

Contents: NOTES

Sheet: A12

Job No. 24200.00

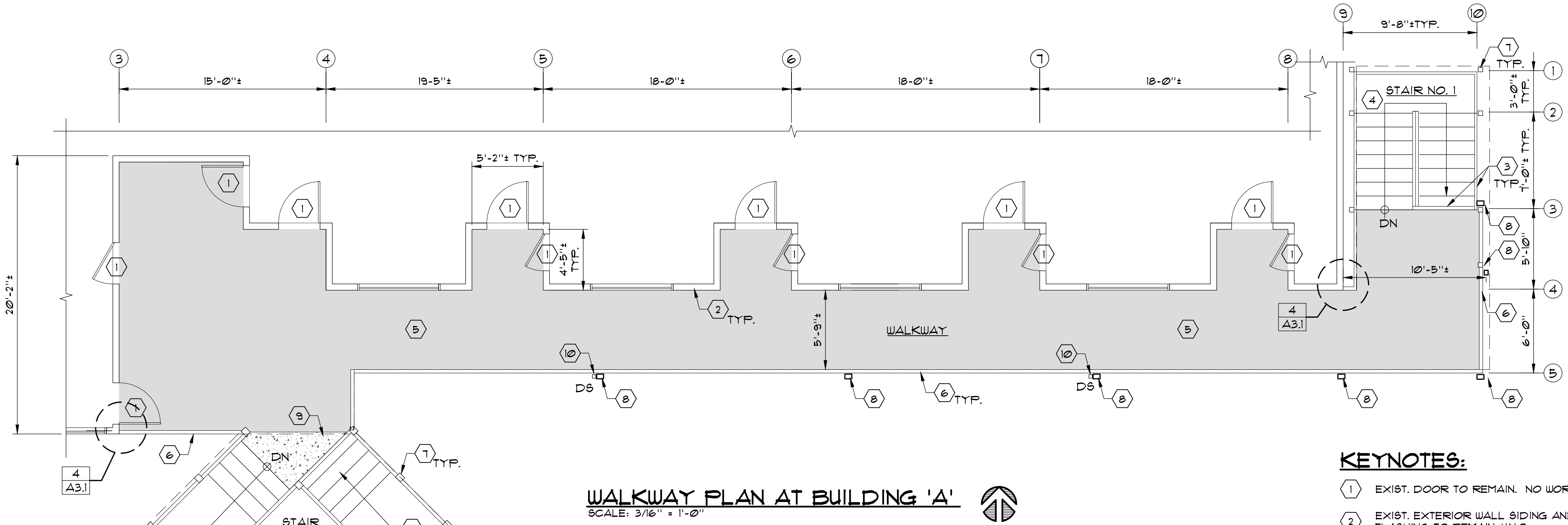

**WALKWAY PLAN AT BUILDING 'A'**  
SCALE: 3/16" = 1'-0"

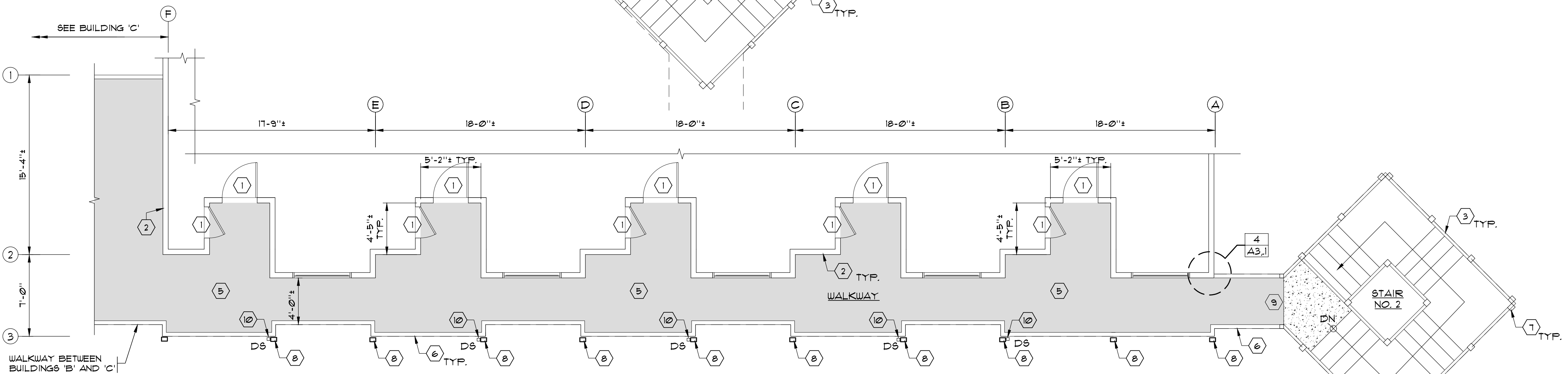

**WALKWAY PLAN AT BUILDING 'B'**  
SCALE: 3/16" = 1'-0"

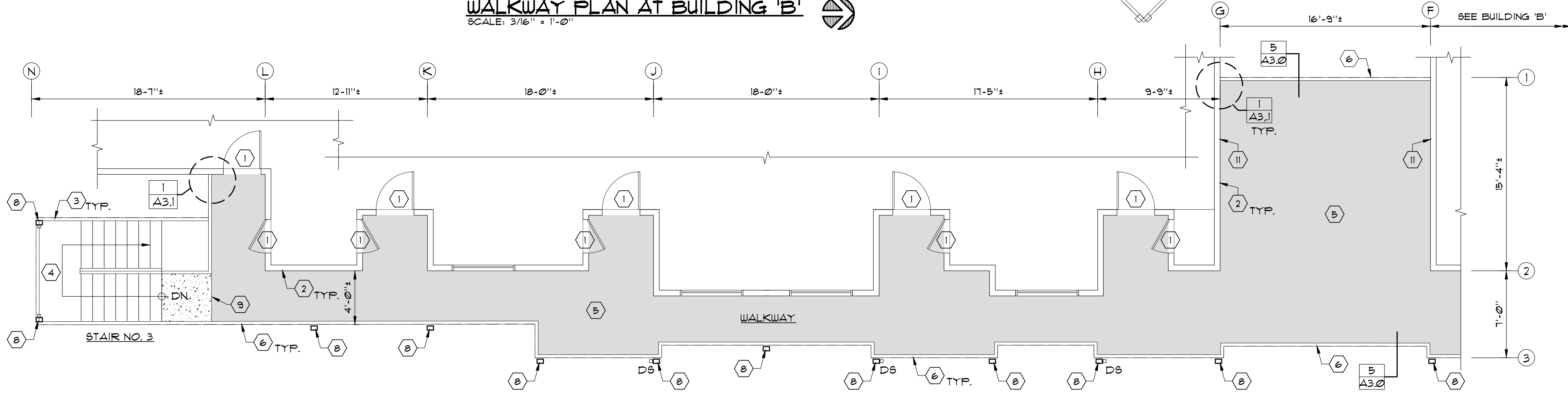

**WALKWAY PLAN AT BUILDING 'C'**  
SCALE: 3/16" = 1'-0"

**KEYNOTES:**

- 1 EXIST. DOOR TO REMAIN. NO WORK.
- 2 EXIST. EXTERIOR WALL SIDING AND BASE OF WALL FLASHING TO REMAIN, UNO.
- 3 REMOVE AND DISCARD EXIST. WOOD TOP RAIL. INSTALL NEW COMPOSITE WOOD TOP RAIL TO EXIST. STAIR GUARDRAIL TO REMAIN.
- 4 EXIST. STAIR TO REMAIN. NO WORK UNO.
- 5 EXIST. WALKWAY. REMOVE SOFFIT (4" MIN.) VENT STRIP AND FLYWOOD FLOOR SHEATHING AS REQUIRED TO PERFORM STRUCTURAL WORK. INSTALL NEW SOFFIT, VENT STRIP AND FLYWOOD SHEATHING WHERE REMOVED. CLEAN EXIST. WATERPROOF MEMBRANE AND INSTALL NEW DRIP EDGE AND CORNER FLASHINGS AND WATERPROOF MEMBRANE OVER THE ENTIRE SURFACE. TAPE, MUD, SAND (LEVEL 4), FRIME AND PAINT ENTIRE SOFFIT.
- 6 EXIST. WALKWAY GUARDRAIL. TEMPORARILY REMOVE AND STORE. REMOVE AND DISCARD EXIST. WOOD TOP RAIL AND INSTALL NEW COMPOSITE TOP RAIL. INSTALL NEW BLOCKING AND RE-INSTALL GUARDRAILS. REF. STRUCT.
- 7 EXIST. STAIR STEEL BEAMS, COLUMNS, ANGLES, ETC TO REMAIN. REMOVE CORROSION, CLEAN, AND PAINT WITH A ZINC RICH PRIMER AND EXTERIOR PAINT.
- 8 EXIST. WALKWAY WOOD BEAMS, KNEE BRACE AND COLUMNS TO BE REMOVED. PROVIDE TEMP. SUPPORT AS REQUIRED. REF. STRUCT. NEW STEEL BEAM AND COLUMN. REF. STRUCT.
- 9 REMOVE AND REPLACE THRESHOLD BETWEEN STAIR LANDING AND WALKWAY. REF. DETAIL.
- 10 EXIST. DOWNSPOUT (DS). REMOVE AND REPLACE TO MATCH EXIST.
- 11 PRIME, SEAL, AND PAINT EXTERIOR WALL.

Project No.	24200000
Revision	2/20/2026
Client	GREENBRIDGE APARTMENTS A, B AND C
Location	9915 1TH AVE. SEATTLE, WA
Scale	3/16" = 1'-0"
Author	G. MARCONDES
Checker	V. PAN
Engineer	N.L.F.
Date	15 AUG. 2025
Approved	

**PACIFIC**  
ENGINEERING TECHNOLOGIES, INC.  
4444 Woodland Park Ave. N., Suite 100, Seattle, Washington 98103-7489  
(206) 281-2300

Contents	WALKWAY PLANS
Project	GREENBRIDGE APARTMENTS A, B AND C WALKWAY REPAIR
Location	9915 1TH AVE. SEATTLE, WA
Scale	3/16" = 1'-0"
Author	G. MARCONDES
Checker	V. PAN
Engineer	N.L.F.
Date	15 AUG. 2025
Approved	

THE INFORMATION PRESENTED ON THESE DRAWINGS IS TO THE LEVEL OF DETAIL FOR CONSTRUCTION COST ESTIMATION ONLY, NOT FOR ACTUAL CONSTRUCTION

**PRELIMINARY**

ALL INFORMATION ON THIS DOCUMENT IS THE EXCLUSIVE PROPERTY OF PACIFIC ENGINEERING TECHNOLOGIES, INC. © COPYRIGHT 2026

**A2.0**  
Sheet  
Job No. 24200000

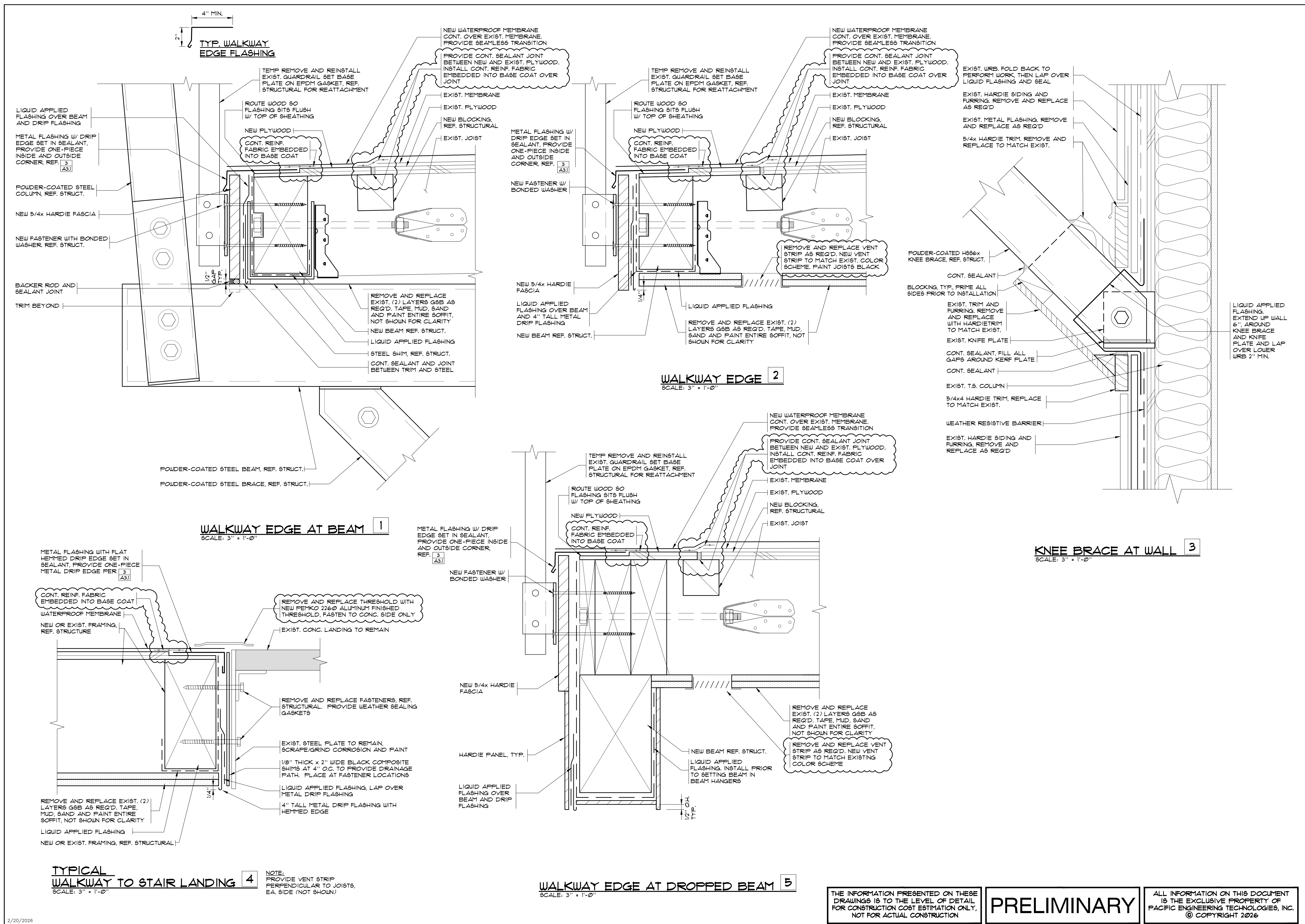

**WALKWAY EDGE AT BEAM 1**  
SCALE: 3" = 1'-0"

**WALKWAY EDGE 2**  
SCALE: 3" = 1'-0"

**KNEE BRACE AT WALL 3**  
SCALE: 3" = 1'-0"

**TYPICAL WALKWAY TO STAIR LANDING 4**  
SCALE: 3" = 1'-0"

**WALKWAY EDGE AT DROPPED BEAM 5**  
SCALE: 3" = 1'-0"

NOTE:  
PROVIDE VENT STRIP  
PERPENDICULAR TO JOISTS,  
E.A. SIDE (NOT SHOWN)

THE INFORMATION PRESENTED ON THESE  
DRAWINGS IS TO THE LEVEL OF DETAIL  
FOR CONSTRUCTION COST ESTIMATION ONLY.  
NOT FOR ACTUAL CONSTRUCTION

**PRELIMINARY**

ALL INFORMATION ON THIS DOCUMENT  
IS THE EXCLUSIVE PROPERTY OF  
PACIFIC ENGINEERING TECHNOLOGIES, INC.  
© COPYRIGHT 2026

Date: 2/20/26  
Revision: BID SET  
No. 3  
Designed: G. MARCONDES  
Drawn: VHN  
Checked: NLF  
Date: 15 AUG, 2025  
Approved: IB ALG

**PACIFIC**  
ENGINEERING TECHNOLOGIES, INC.  
4444 Woodland Park Ave. N. - Suite 100 Seattle, Washington 98103-7499  
(206) 281-1500

Contents  
**DETAILS**

Project: **GREENBRIDGE APARTMENTS BUILDINGS A, B AND C WALKWAY REPAIR**  
9915 1TH AVE. SEATTLE, WA

Sheet: **A3.0**  
Job No. 24200.00

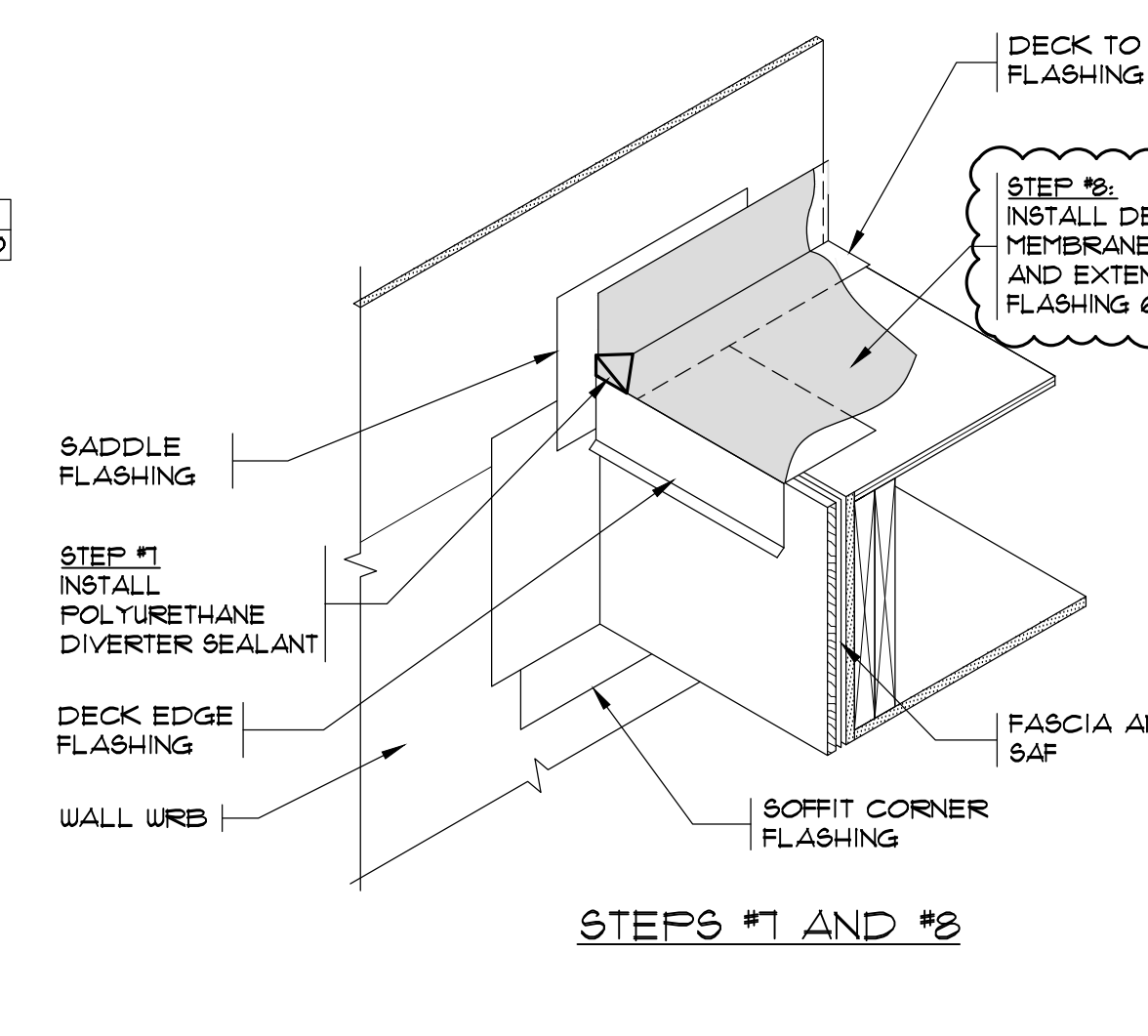
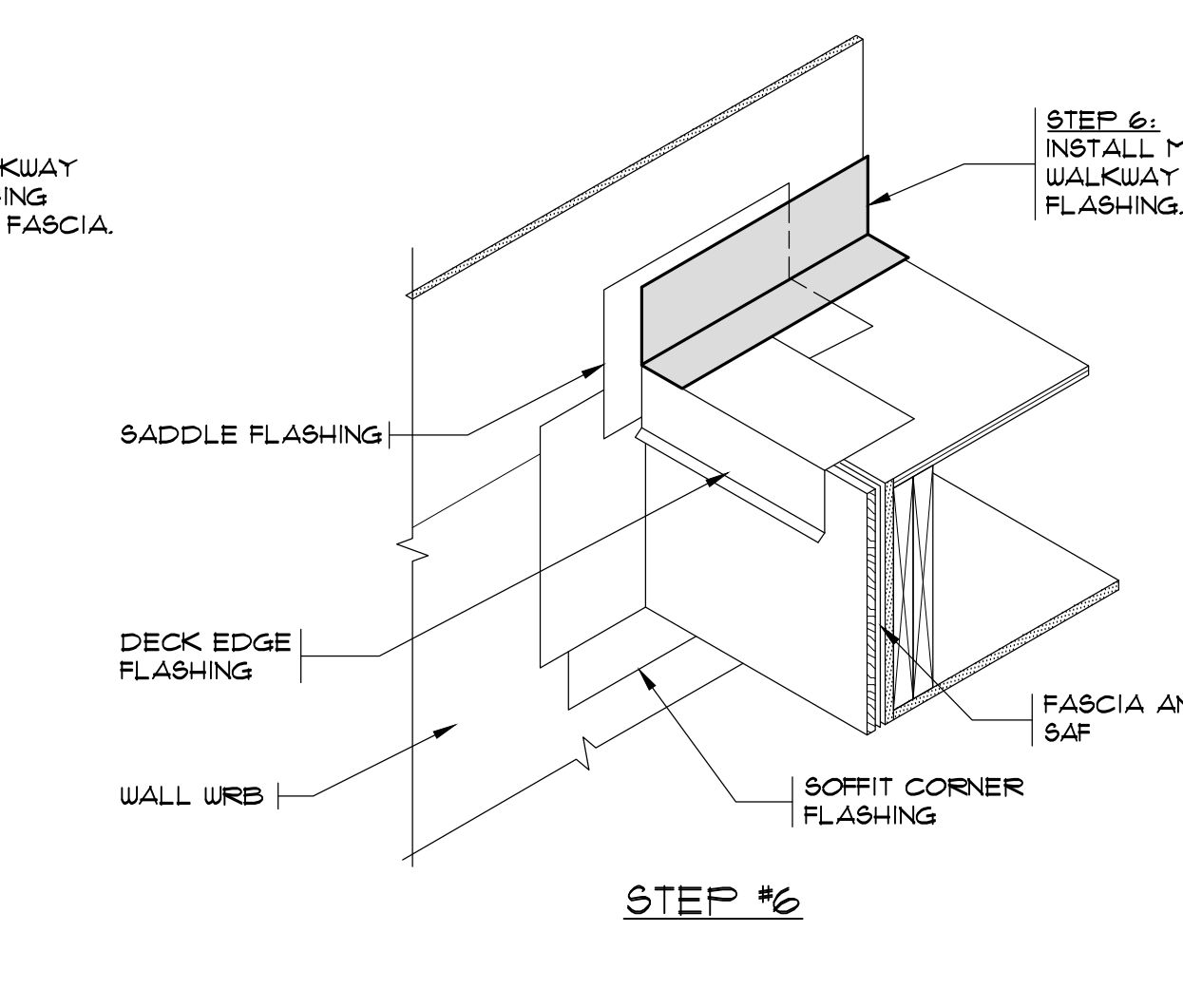
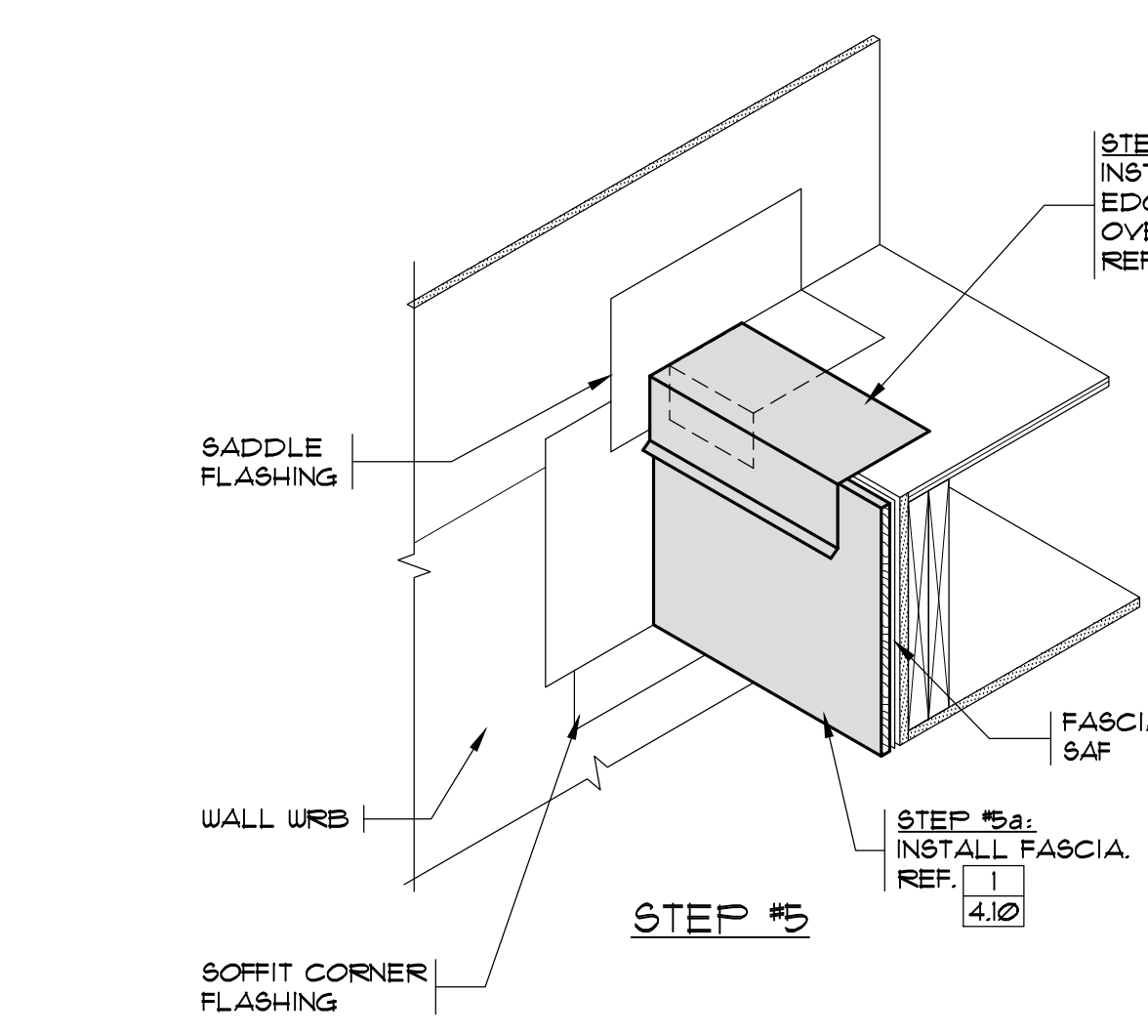
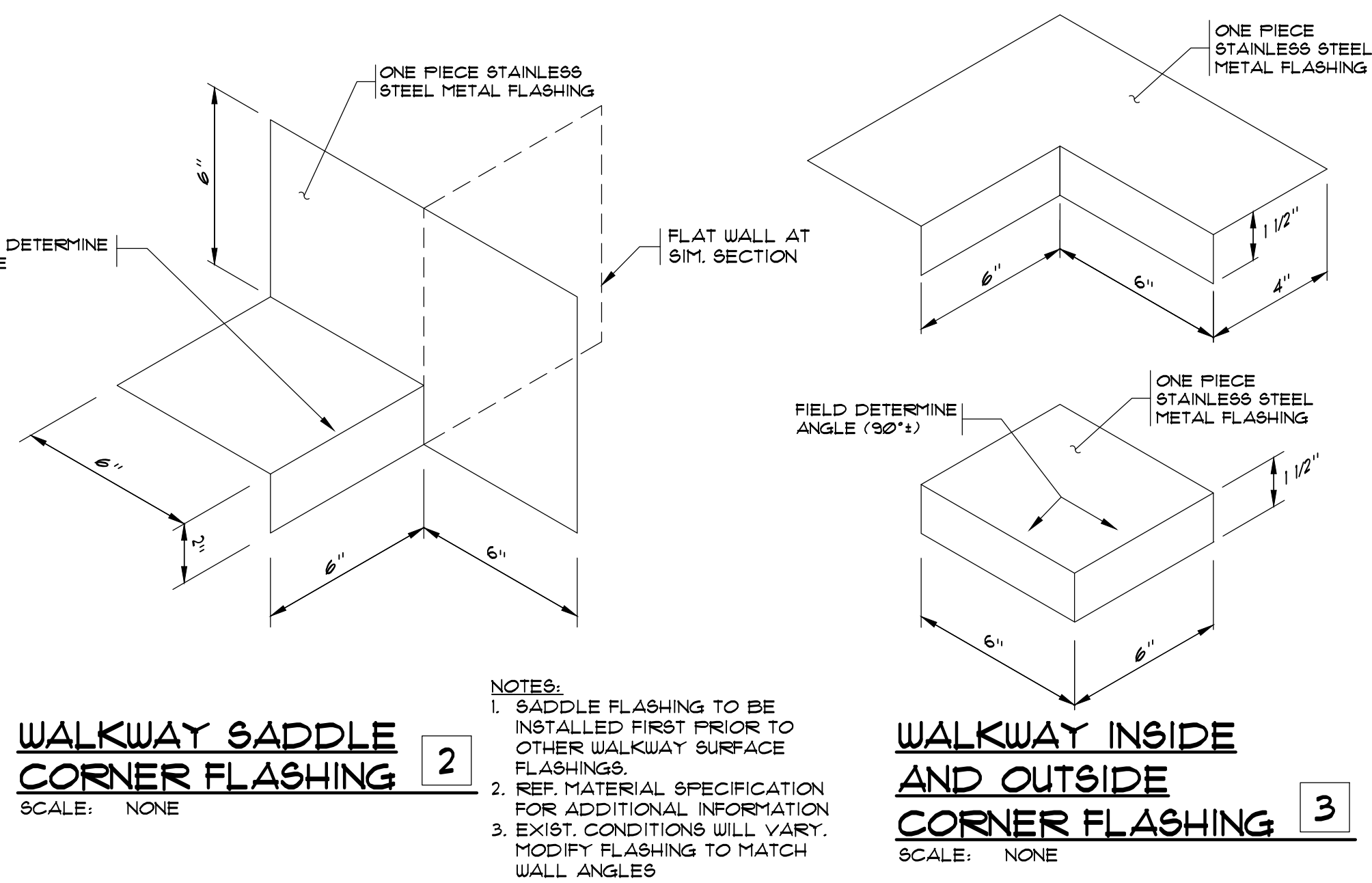
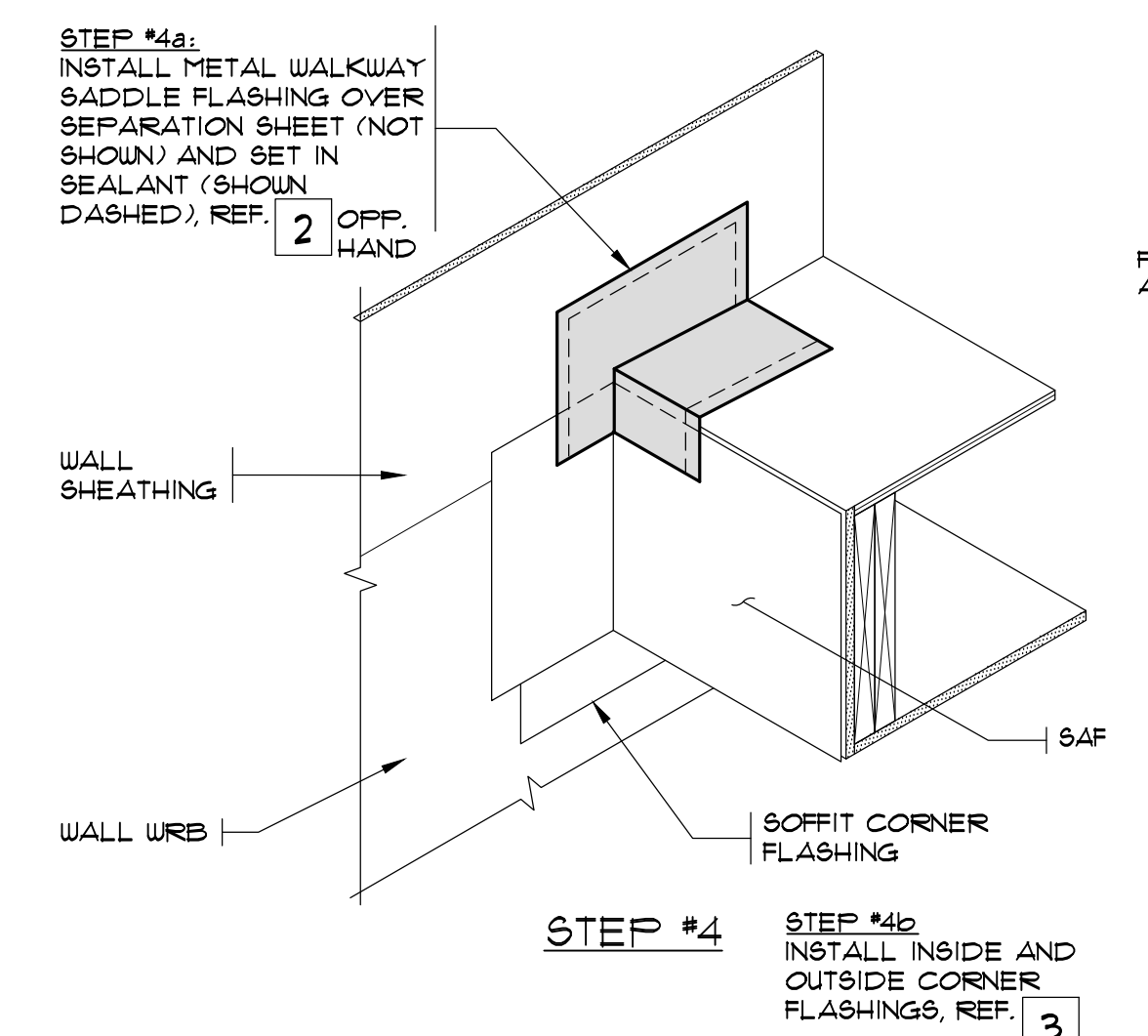
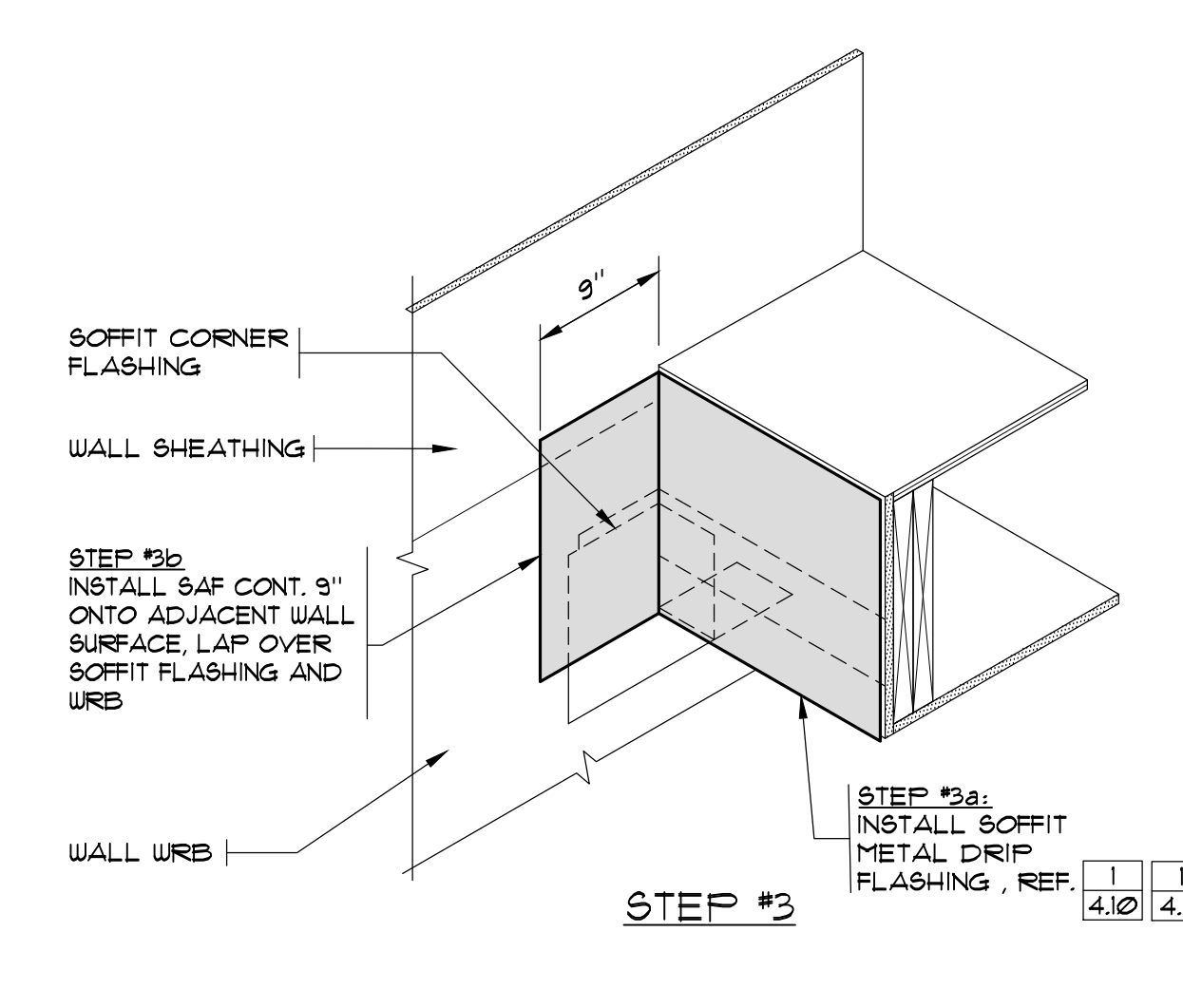
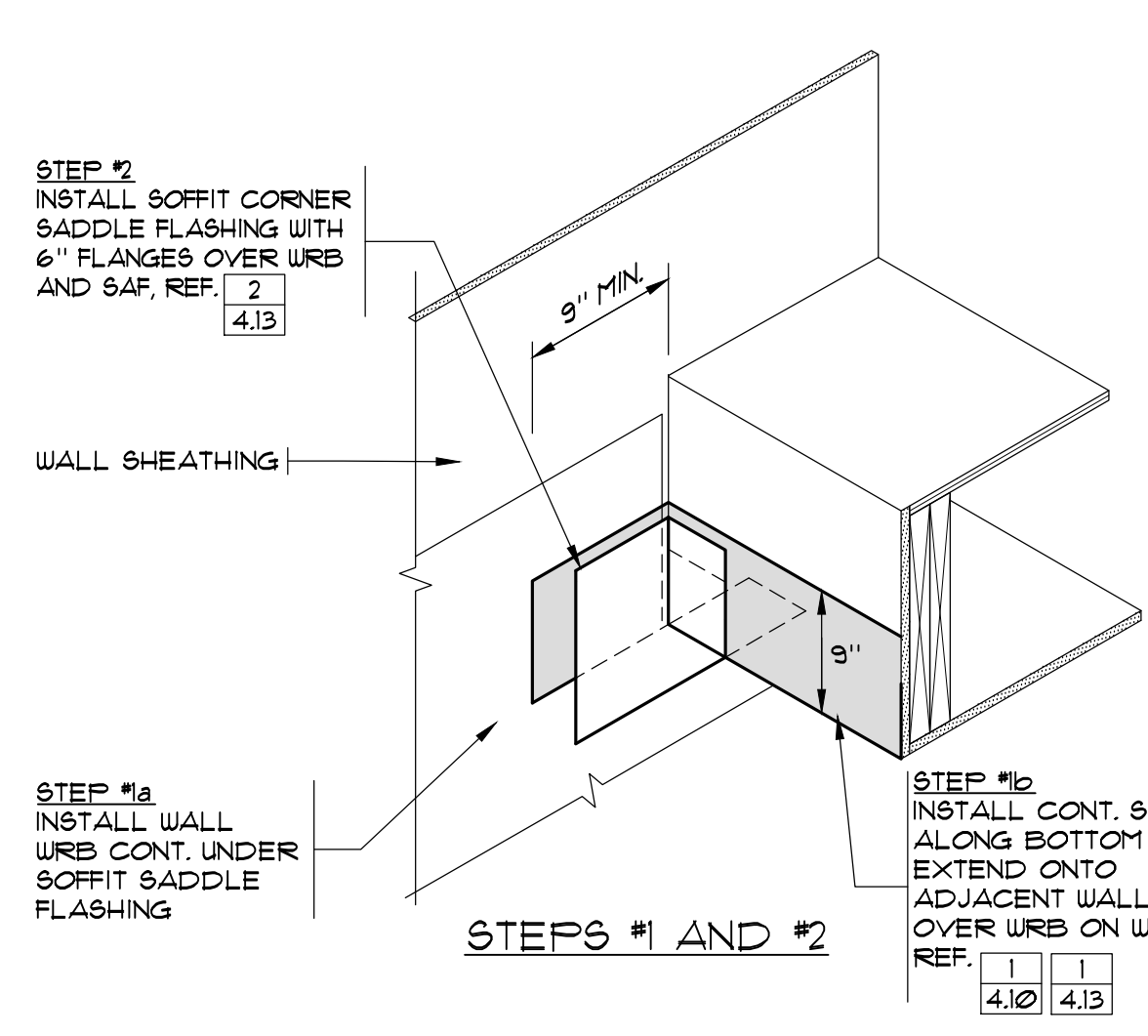

**TYPICAL WALKWAY SADDLE FLASHING AT FLAT WALL** 1  
SCALE: N.T.S.

NOTES:  
1. FRAMING CONDITIONS SHOWN ARE SCHEMATIC AND DO NOT SHOW EXIST. BEAM AND EXISTING FIELD CONDITIONS MAY DIFFER FROM WHAT IS SHOWN  
2. SIDING NOT SHOWN

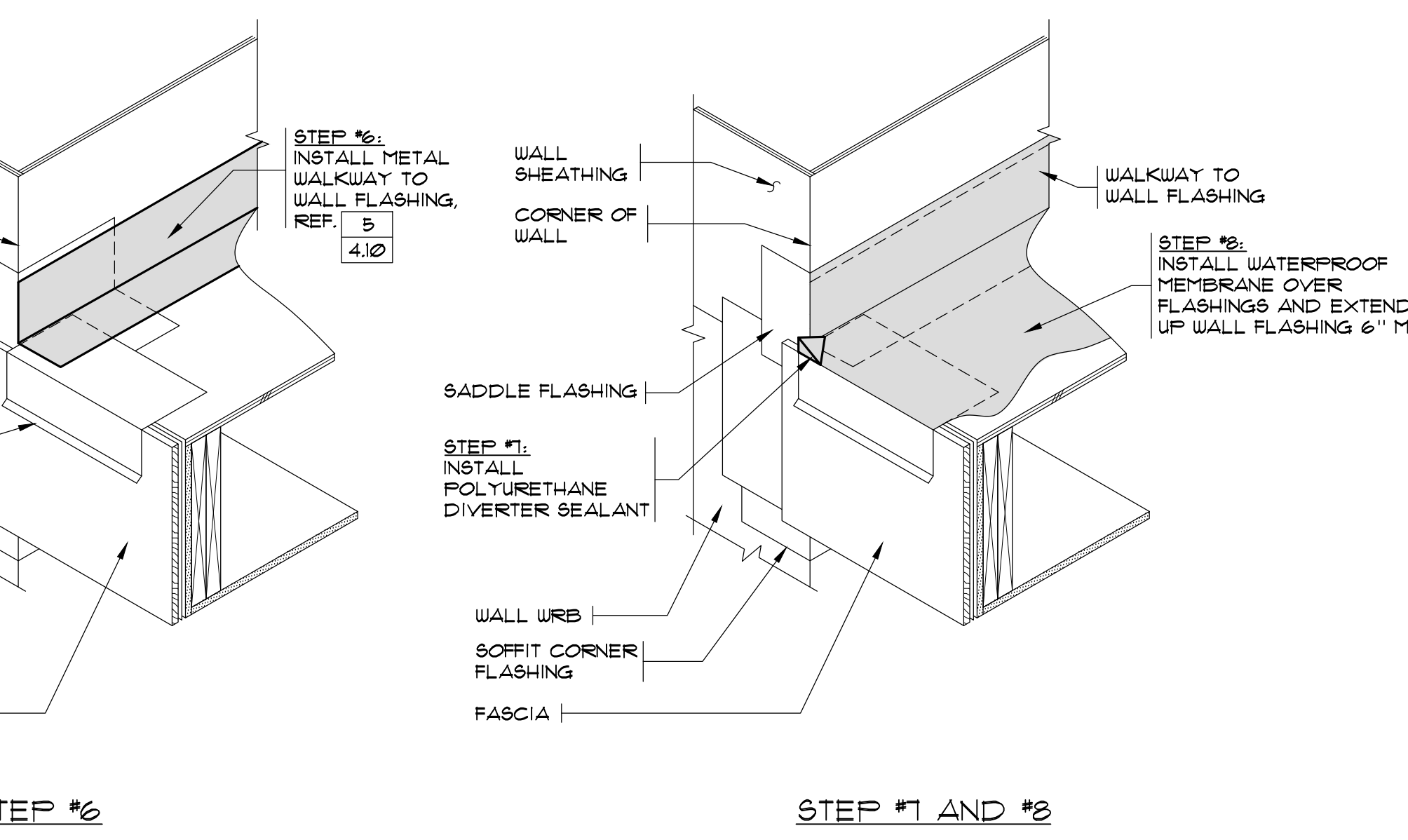
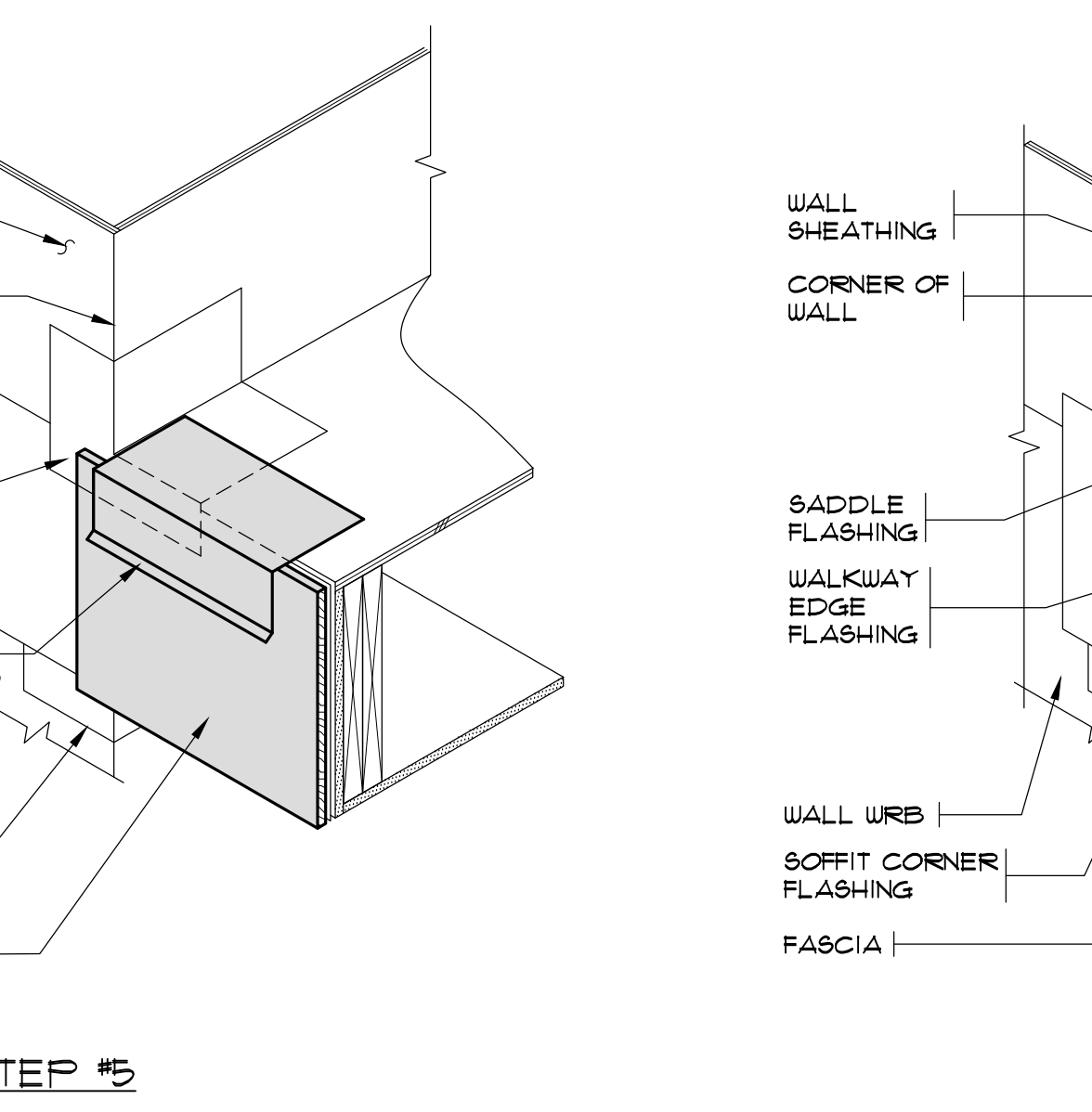
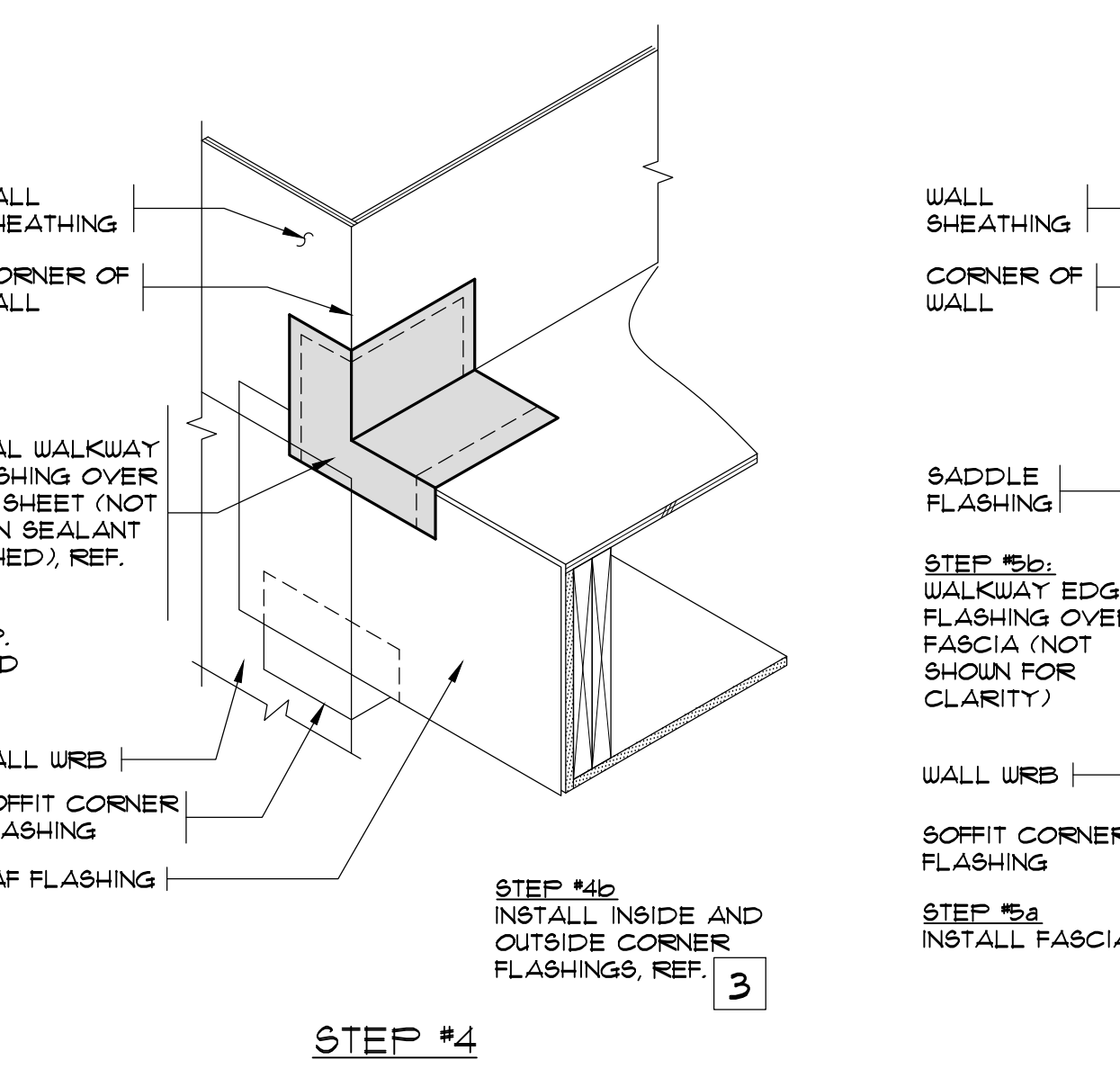
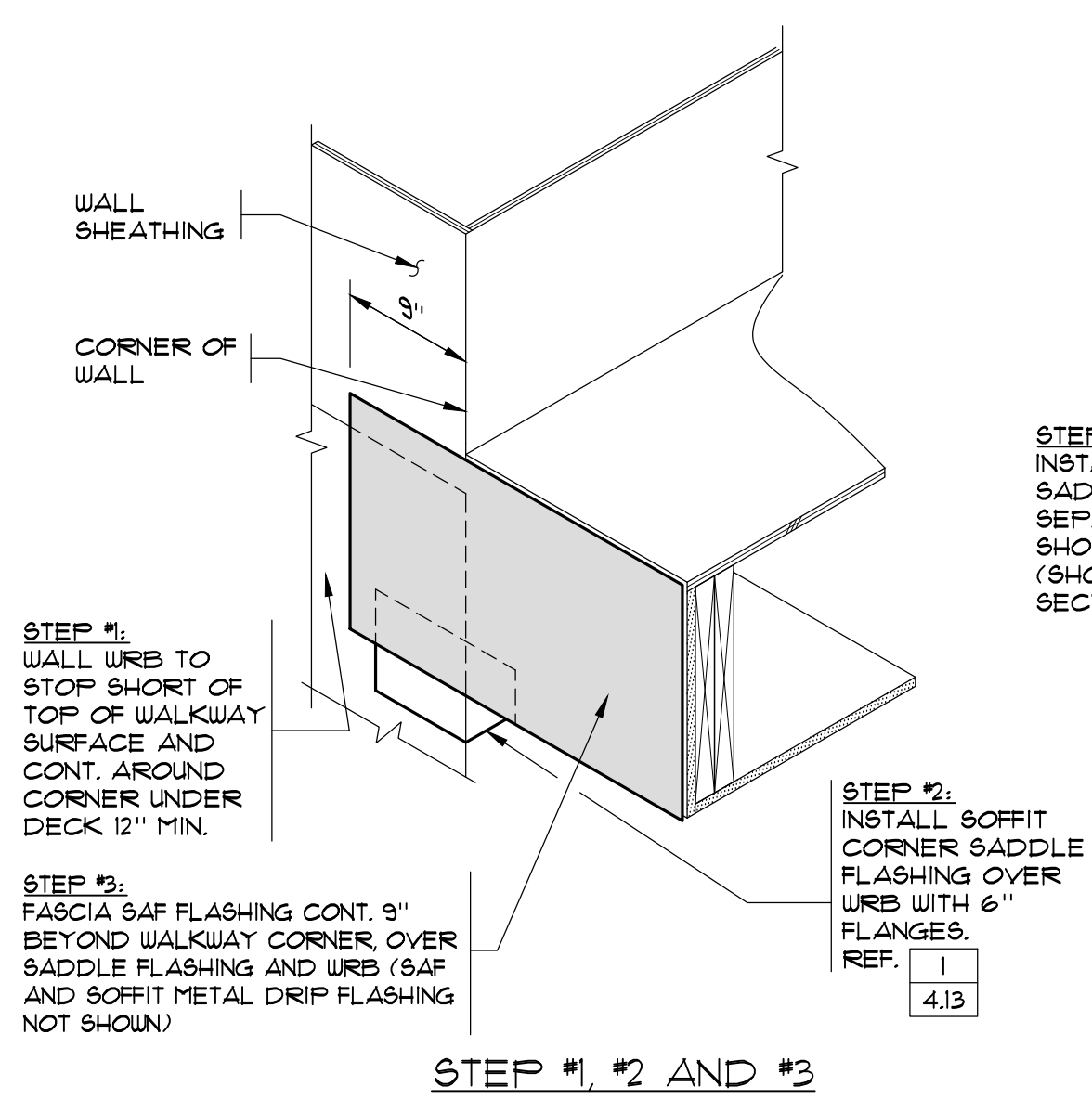

**TYPICAL WALKWAY SADDLE FLASHING AT WALL CORNER** 4  
SCALE: N.T.S.

NOTES:  
1. SCHEMATIC FIELD CONDITIONS MAY DIFFER FROM WHAT IS SHOWN  
2. FURRING AND SIDING NOT SHOWN

THE INFORMATION PRESENTED ON THESE DRAWINGS IS TO THE LEVEL OF DETAIL FOR CONSTRUCTION COST ESTIMATION ONLY, NOT FOR ACTUAL CONSTRUCTION

**PRELIMINARY**

ALL INFORMATION ON THIS DOCUMENT IS THE EXCLUSIVE PROPERTY OF PACIFIC ENGINEERING TECHNOLOGIES, INC. © COPYRIGHT 2026

Date	2/20/26
Revision	BID SET
No.	
Designed	G. MARCONDES
Drawn	V.H.N.
Checked	N.L.F.
Date	15 AUG, 2025
Approved	
<b>PACIFIC ENGINEERING TECHNOLOGIES, INC.</b> 4444 Woodland Park Ave. N. - Suite 100 Seattle, Washington 98103-7499 (206) 281-7500	

Project	GREENBRIDGE APARTMENTS BUILDINGS A, B AND C WALKWAY REPAIR
Location	9935 11TH AVE. SEATTLE, WA
Contents	DETAILS
Sheet	A3.1
Job No.	24200.00

**STRUCTURAL NOTES:**

**CODE:**  
THE WASHINGTON STATE BUILDING CODE (WSBC) 2021 EDITION AND THE 2021 WASHINGTON STATE EXISTING BUILDING CODE (WSBEC).

**LIVE LOADS:**  
ROOF SNOW LOAD 25 PSF  
WALKWAY 100 PSF

**FOUNDATION:**  
BEFORE WORK BEGINS, LOCATE ALL UNDERGROUND UTILITIES BY CONTACTING "CALL BEFORE YOU DIG" AT 1-800-424-5555 OR 811. HOWEVER, THIS SERVICE DOES NOT HAVE A COMPLETE DATABASE OF ALL OBSTRUCTIONS, THEREFORE OTHER LOCATING SERVICES MAY ALSO BE NECESSARY.

EXTEND FOOTINGS TO FIRM UNDISTURBED SOIL OF 1500 PSF BEARING CAPACITY. EXTEND ALL FOOTINGS A MINIMUM OF 1'- 6" BELOW ADJACENT EXTERIOR FINISHED GRADE.

**CONCRETE:**  
CONCRETE f'c = 2500 PSI AT 28 DAYS.

CONCRETE PROTECTION FOR REINFORCING SHALL BE AS FOLLOWS:

BOTTOM OF FOOTINGS 3"

ALL CONCRETE IN FOOTINGS AND SLABS SHALL BE PLACED IN A MONOLITHIC POUR UNLESS SHOWN OTHERWISE OR APPROVED BY THE ENGINEER PRIOR TO PLACING. ALUMINUM CONDUIT AND ACCESSORIES SHALL NOT BE EMBEDDED IN CONCRETE.

**REINFORCING STEEL:**  
DEFORMED BILLET STEEL CONFORMING TO ASTM A615 (STANDARD Ø4, 2013 CURRENT), GRADE 60.

**STRUCTURAL AND MISCELLANEOUS STEEL:**  
ANGLES AND PLATES ASTM A36 Fy = 36,000 PSI. STEEL TUBES ASTM A500, GRADE "C" Fy = 50,000 PSI. ALL FABRICATION AND ERECTION SHALL BE IN ACCORDANCE WITH THE LATEST EDITION OF AISC "STEEL CONSTRUCTION MANUAL."

ALL WELDS SHALL BE 3/16" MINIMUM CONTINUOUS FILLET WELDS USING AWS D11 CLASS E70 ELECTRODES UNLESS NOTED OTHERWISE. ALL WELDING SHALL BE PERFORMED BY WELDERS CERTIFIED BY WABO.

ALL STEEL SHALL BE HOT-DIPPED GALVANIZED IN ACCORDANCE WITH ASTM A123. REPAIR ALL SCRAPER, DINGS, WELDS, ETC., IN ACCORDANCE WITH ASTM A120.

**STEEL BOLTS:**  
ALL BOLTS AND THREADED RODS SHALL BE ASTM A307 HOT-DIPPED GALVANIZED IN ACCORDANCE WITH ASTM A193-CLASS C UNLESS NOTED OTHERWISE. GALVANIZED BOLTS SHOULD BE INSTALLED IN STANDARD SIZE HOLES UNLESS NOTED OTHERWISE. PROVIDE CUT WASHERS FOR ALL BOLT HEADS AND NUTS BEARING ON WOOD.

**NAILS:**  
NAILING SHALL BE IN ACCORDANCE W/ FASTENING SCHEDULE TABLES 11-13 IN ICC-E9 EVALUATION REPORT E9R-1539 PREPARED FOR THE INTERNATIONAL STAPLE, NAIL AND TOOL ASSOCIATION (ISANTA). ALL NAILS SHALL HAVE STANDARD SIZE ROUND HEADS UNLESS NOTED OTHERWISE ON THE DRAWINGS. NAIL LENGTHS AND DIAMETERS SHALL BE AS FOLLOWS:  
10d 3" x Ø.131" DIA.  
10d COMMON 3" x Ø.148" DIA.

ALL NAILS EXPOSED TO WEATHER OR IN CONTACT WITH PRESSURE TREATED WOOD SHALL BE HOT-DIPPED GALVANIZED PER ASTM A193-CLASS D.

**SCREWS INSTALLED IN WOOD:**  
SCREWS FOR INSTALLATION IN WOOD SHALL BE MANUFACTURED BY THE SIMPSON STRONG-TIE COMPANY, IN ACCORDANCE WITH ICC-E9 REPORT E9R-2236 AND IAFMO UES REPORT #92. THE SCREW DIAMETERS AND LENGTHS ARE AS FOLLOWS:

SDU622 (Ø.22" DIAMETER LENGTHS: 3" TO 10")

SDU622 SCREWS HAVE PROPRIETARY CORROSION-RESISTANT COATINGS EQUIVALENT TO ASTM A193-CLASS D AND ARE INTENDED TO BE USED WHERE EXPOSED TO WEATHER OR IN CONTACT WITH MOST PRESSURE TREATED WOOD. EQUIVALENT SCREWS BY OTHER MANUFACTURERS MAY BE SUBSTITUTED PROVIDED THEY HAVE ICC-E9 APPROVAL FOR EQUAL LOAD CAPACITIES AND CORROSION RESISTANCE.

**LIGHT GAUGE FRAMING CONNECTORS:**  
NOTATIONS ON DRAWINGS RELATING TO FRAMING CLIPS, JOIST HANGERS AND OTHER CONNECTING DEVICES REFER TO CATALOG NUMBERS OF CONNECTORS MANUFACTURED BY THE SIMPSON STRONG-TIE COMPANY, DUBLIN, CALIFORNIA. EQUIVALENT DEVICES BY OTHER MANUFACTURERS MAY BE SUBSTITUTED PROVIDED THEY HAVE ICC-E9 APPROVAL FOR EQUAL LOAD CAPACITIES. CONNECTORS SHALL BE FASTENED TO THE FRAMING MEMBERS USING THE NUMBER AND TYPE OF FASTENERS CALLED FOR BY MANUFACTURER.

CONNECTORS IN CONTACT WITH PRESSURE TREATED LUMBER SHALL BE ZMAX/HDG GALVANIZED. ALL FASTENERS USED WITH ZMAX/HDG GALVANIZED CONNECTORS SHALL BE HOT-DIPPED GALVANIZED PER ASTM A193-CLASS D OR SDS SCREWS WITH PROPRIETARY COATING.

**STRUCTURAL LUMBER GRADES AND SHEATHING RATINGS:**  
ALL LUMBER SHALL BE GRADED IN ACCORDANCE WITH CURRENT WUPA STANDARD GRADING RULES FOR WESTERN LUMBER. USE THE FOLLOWING SPECIES AND MINIMUM GRADE:

BLOCKING HEM-FIR #1 Fb = 915 PSI OR #2 Fb = 850 PSI

ALL SHEATHING SHALL BE APA PERFORMANCE RATED PANELS. SHEATHING SHALL BE PLYWOOD OR ORIENTED STRAND BOARD (OSB). BOND CLASSIFICATION SHALL BE EXPOSURE 1 WHERE PROTECTED FROM THE WEATHER. BOND CLASSIFICATION SHALL BE EXTERIOR WHERE EXPOSED, SUCH AS EAVE AND SIDING APPLICATIONS. ALL ABUTTING PANELS SHALL HAVE 1/8" GAP.

**ENGINEERED WOOD PRODUCTS:**  
PSL ENGINEERED WOOD SHALL BE MANUFACTURED BY WEYERHAEUSER IN ACCORDANCE WITH ICC-E9 E9R-1987. ALTERNATE MANUFACTURERS REQUIRE ENGINEER'S APPROVAL PRIOR TO FABRICATION. USE THE FOLLOWING MINIMUM GRADE:

PARALLAM PSL BEAMS: GRADE 22E Fb = 2300 PSI

**GLUED LAMINATED LUMBER:**  
DOUGLAS FIR-LARCH GRADE 24F-V4 (Fb=2400 PSI) FOR SINGLE SPAN BEAMS. ALL GLULAM MATERIALS SHALL CONFORM TO THE REQUIREMENTS OF ANSI/AITC A1901 AND BE STAMPED WITH AN AITC QUALITY MARK OR AN APA-IBS TRADEMARK. ADHESIVES USED IN THE GLULAM MANUFACTURING PROCESS SHALL CONFORM TO AITC 408 FOR WET USE ADHESIVES. GLULAM MEMBERS SHALL BE MANUFACTURED FROM DOUGLAS FIR LAMINATING LUMBER. ALL BEAMS SHALL HAVE ZERO CAMBER UNLESS NOTED OTHERWISE. MEMBERS EXPOSED TO VIEW IN THE COMPLETED WORK SHALL BE ARCHITECTURAL APPEARANCE GRADE.

**GENERAL WOOD FRAMING NOTES:**  
1. MINIMUM NAILING SHALL BE IN ACCORDANCE WITH FASTENING SCHEDULE TABLES 11-13 IN ICC-E9 EVALUATION REPORT E9R-1539.  
2. PROVIDE CUT WASHERS FOR ALL BOLT HEADS AND NUTS BEARING ON WOOD.  
3. CURRENT WSBC BUILDING CODES ARE AVAILABLE ONLINE FOR FREE PUBLIC ACCESS AT CODES.ICCSAFE.ORG.

**WALKWAY SHEATHING:**  
APPLY PLYWOOD TO MATCH EXISTING THICKNESS 23/32" MIN. NAILED TO JOISTS WITH 10d RING SHANK NAILS AT 6" O.C. AT ALL SUPPORTED PANEL EDGES AND AT 12" O.C. ALONG INTERMEDIATE SUPPORTS. UNSUPPORTED PANEL EDGES SHALL BE TONGUE-AND-GROOVE OR BLOCKED. THE CUT EDGES OF EXISTING SHEATHING PANELS SHOULD BE BLOCKED. NEW FLOOR SHEATHING TO SPAN ACROSS A MINIMUM OF THREE SUPPORTS.

**SPECIAL INSPECTION:**

**SPECIAL INSPECTOR:**  
THE OWNER OR OWNER'S AUTHORIZED AGENT, OTHER THAN THE CONTRACTOR SHALL EMPLOY ONE OR MORE APPROVED AGENCIES TO PROVIDE SPECIAL INSPECTIONS FOR THE WORK LISTED IN THE STATEMENT OF SPECIAL INSPECTIONS SECTION BELOW. THE CONTRACTOR SHALL PROVIDE ADEQUATE NOTIFICATION TO THE SPECIAL INSPECTORS PRIOR TO THE PERFORMANCE OF WORK REQUIRING SPECIAL INSPECTION.

**STATEMENT OF SPECIAL INSPECTIONS:**  
THE FOLLOWING SPECIAL INSPECTIONS ARE REQUIRED PER CHAPTER 11 OF THE WSBC.

**STEEL:**  
SPECIAL INSPECTION OF STRUCTURAL STEEL SHALL BE IN ACCORDANCE WITH THE QUALITY ASSURANCE INSPECTION REQUIREMENTS IN CHAPTER N OF THE AISC 360 - SPECIFICATIONS FOR STRUCTURAL STEEL BUILDINGS. SPECIAL INSPECTION OF WELDS AND BOLTS SHALL BE IN ACCORDANCE WITH AISC 360-16 SECTION N5.

Date	
Revision	
BID SET	
No.	
Designed	G. MARCONDES
Drawn	V.H.N.
Checked	C.E.J.
Date	15 AUG, 2025
Approved	



Project: GREENBRIDGE APARTMENTS BUILDINGS A, B AND C WALKWAY REPAIR 9915 11th AVE. SEATTLE, WA

Contents: NOTES

Sheet: S1.0

Job No. 24200.00

THE INFORMATION PRESENTED ON THESE DRAWINGS IS TO THE LEVEL OF DETAIL FOR CONSTRUCTION COST ESTIMATION ONLY, NOT FOR ACTUAL CONSTRUCTION

**PRELIMINARY**

ALL INFORMATION ON THIS DOCUMENT IS THE EXCLUSIVE PROPERTY OF PACIFIC ENGINEERING TECHNOLOGIES, INC. © COPYRIGHT 2026

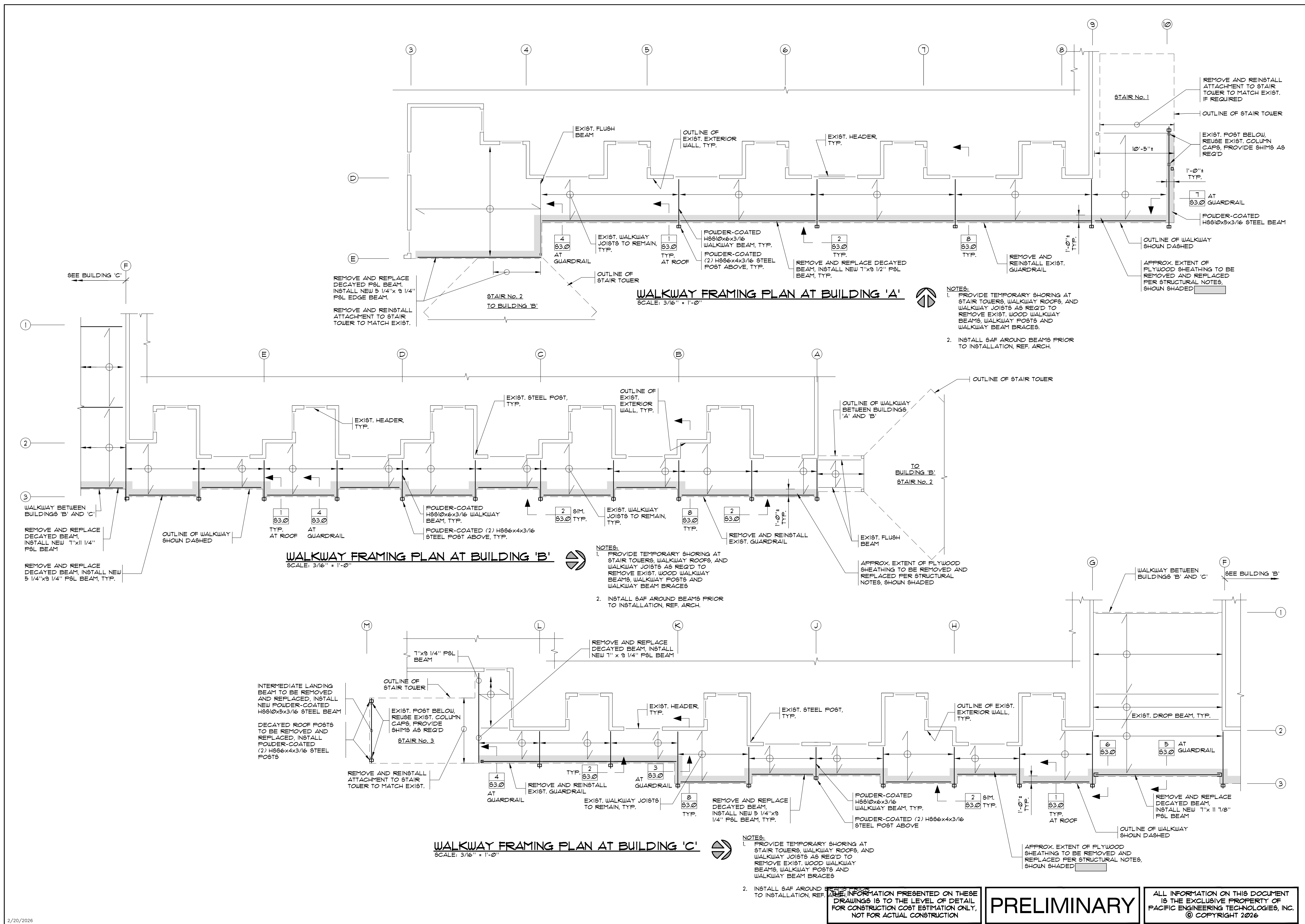

**WALKWAY FRAMING PLAN AT BUILDING 'A'**  
SCALE: 3/16" = 1'-0"

**WALKWAY FRAMING PLAN AT BUILDING 'B'**  
SCALE: 3/16" = 1'-0"

**WALKWAY FRAMING PLAN AT BUILDING 'C'**  
SCALE: 3/16" = 1'-0"

- NOTES:**
1. PROVIDE TEMPORARY SHORING AT STAIR TOWERS, WALKWAY ROOFS, AND WALKWAY JOISTS AS REQ'D TO REMOVE EXIST. WOOD WALKWAY BEAMS, WALKWAY POSTS AND WALKWAY BEAM BRACES.
  2. INSTALL SAF AROUND BEAMS PRIOR TO INSTALLATION, REF. ARCH.

- NOTES:**
1. PROVIDE TEMPORARY SHORING AT STAIR TOWERS, WALKWAY ROOFS, AND WALKWAY JOISTS AS REQ'D TO REMOVE EXIST. WOOD WALKWAY BEAMS, WALKWAY POSTS AND WALKWAY BEAM BRACES.
  2. INSTALL SAF AROUND BEAMS PRIOR TO INSTALLATION, REF. ARCH.

- NOTES:**
1. PROVIDE TEMPORARY SHORING AT STAIR TOWERS, WALKWAY ROOFS, AND WALKWAY JOISTS AS REQ'D TO REMOVE EXIST. WOOD WALKWAY BEAMS, WALKWAY POSTS AND WALKWAY BEAM BRACES.
  2. INSTALL SAF AROUND BEAMS PRIOR TO INSTALLATION, REF. ARCH.

ALL INFORMATION PRESENTED ON THESE DRAWINGS IS TO THE LEVEL OF DETAIL FOR CONSTRUCTION COST ESTIMATION ONLY, NOT FOR ACTUAL CONSTRUCTION

**PRELIMINARY**

ALL INFORMATION ON THIS DOCUMENT IS THE EXCLUSIVE PROPERTY OF PACIFIC ENGINEERING TECHNOLOGIES, INC. © COPYRIGHT 2026

Revision	BID SET
No.	
Designed	G. MARCONDES
Drawn	V.H.N.
Checked	C.E.J.
Date	15 AUG., 2025
Approved	

**PACIFIC**  
ENGINEERING TECHNOLOGIES, INC.  
4444 Woodland Park Ave. N. - Suite 100 Seattle, Washington 98103-7499  
(206) 281-7500

Contents  
**WALKWAY FRAMING PLANS**

Project  
**GREENBRIDGE APARTMENTS BUILDINGS A, B AND C WALKWAY REPAIR**

SEATTLE, WA  
9815 1TH AVE.

Sheet  
**S2.0**

Job No. 24200.00

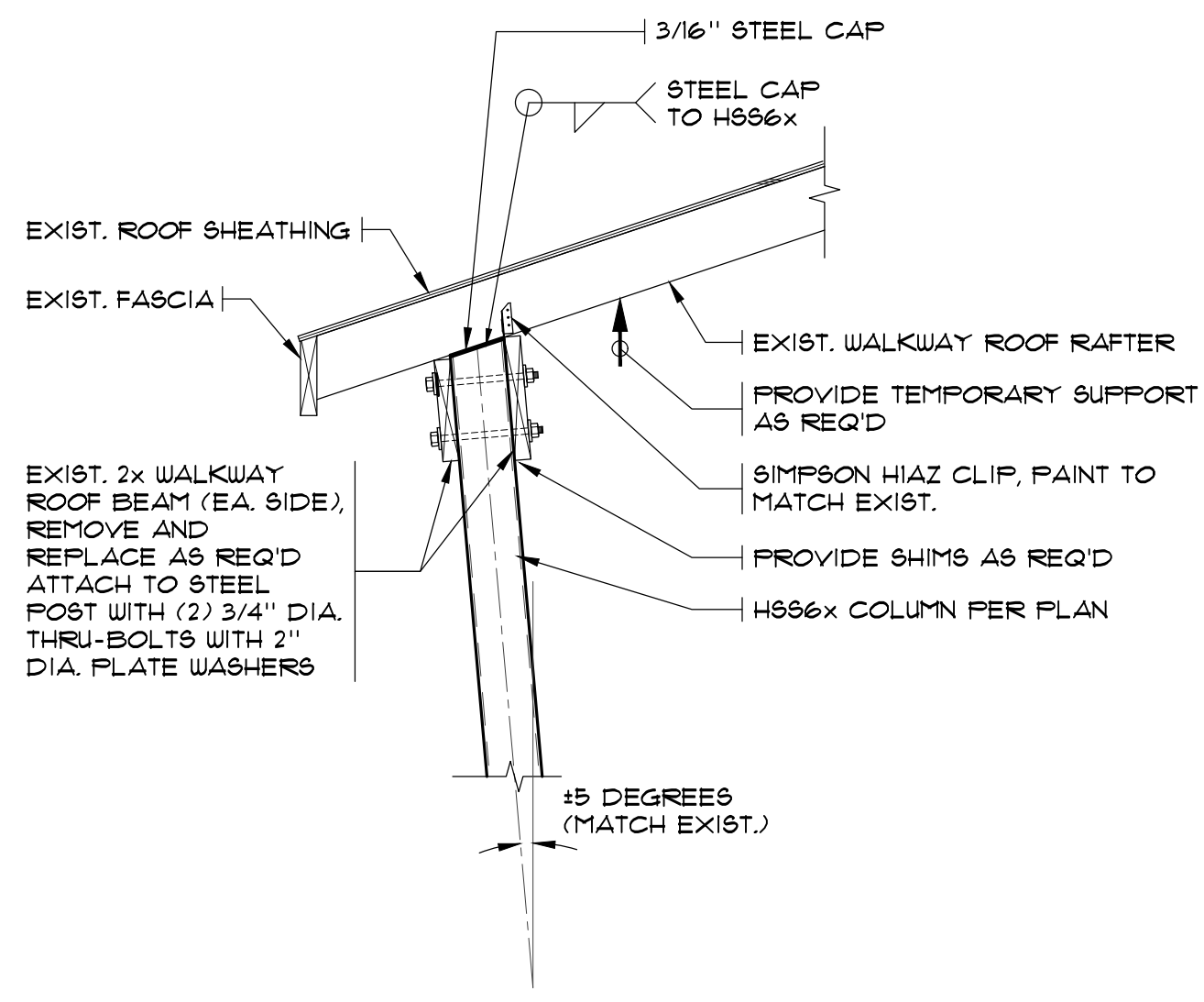

**SECTION 1**  
SCALE: 3/4" = 1'-0"

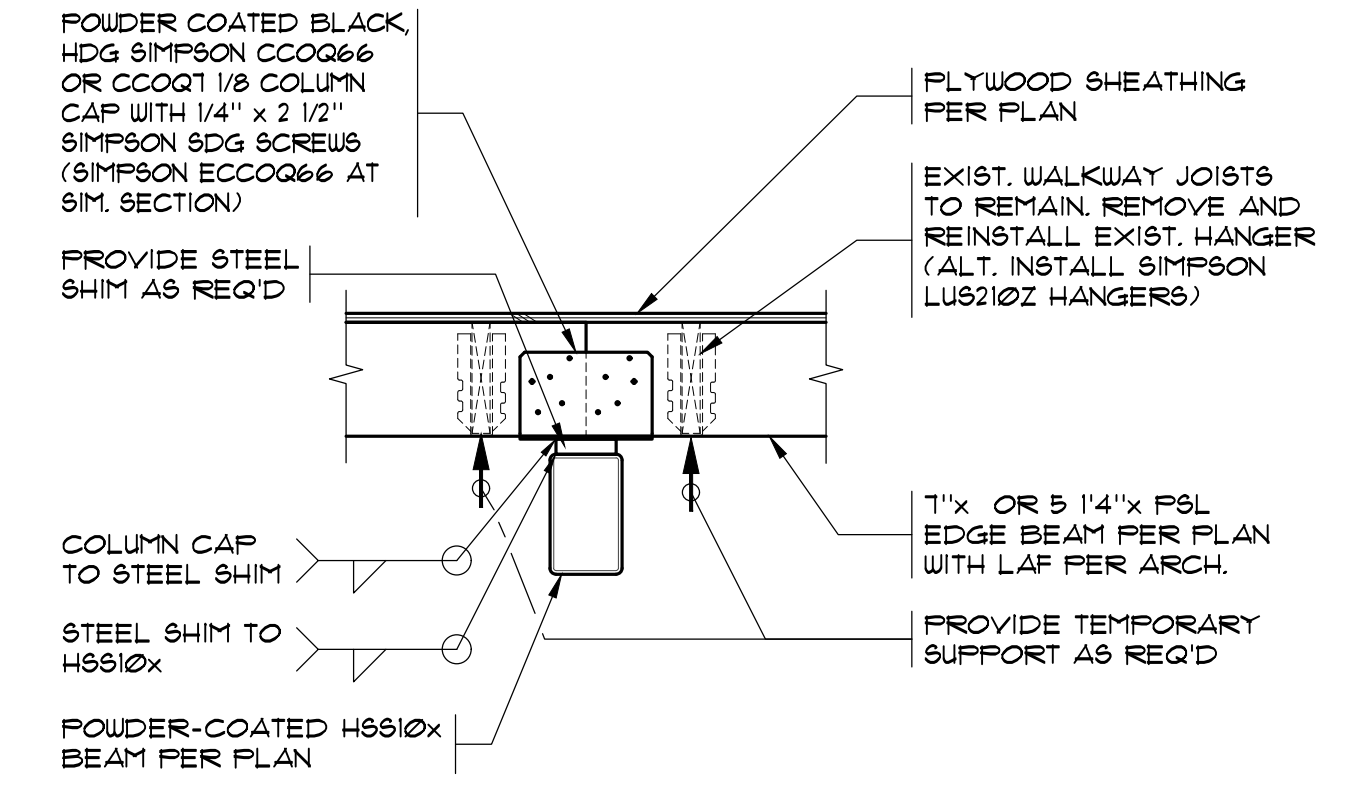

**SECTION 2**  
SCALE: 3/4" = 1'-0"

NOTE:  
GUARDRAIL ATTACHMENT AND BRACE NOT SHOWN FOR CLARITY (OMITTED IN SIM. SECTION)

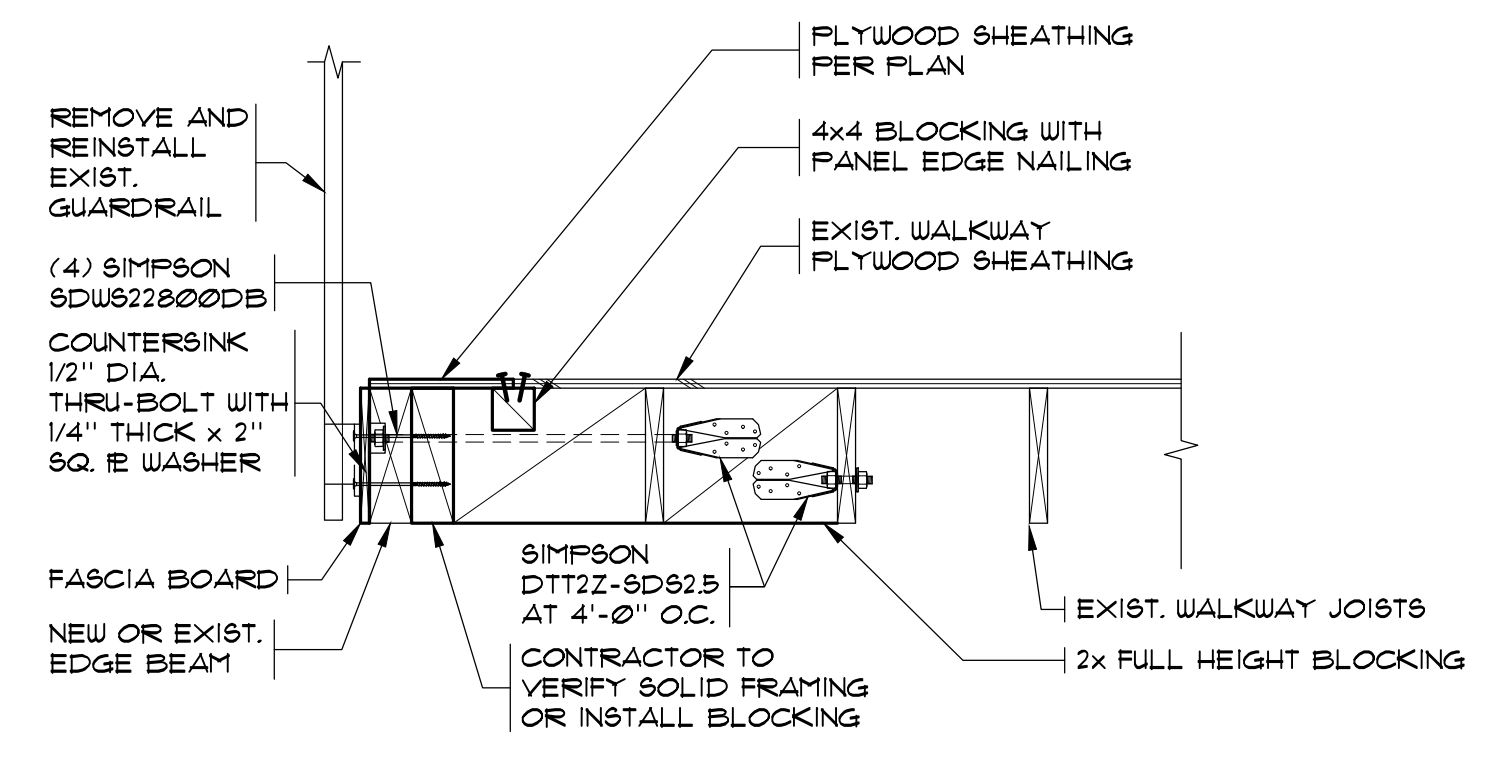

**SECTION 3**  
SCALE: 3/4" = 1'-0"

NOTE:  
FOR INFORMATION NOT SHOWN, REF. SECTION 8

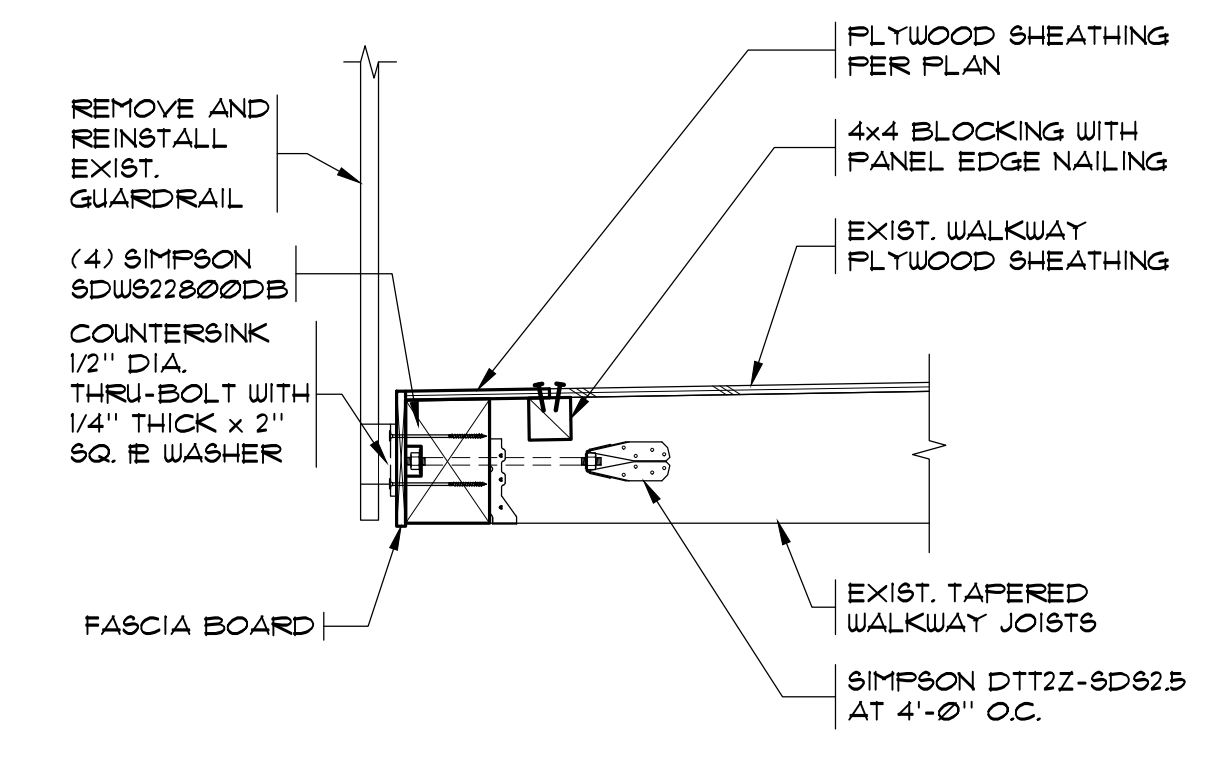

**SECTION 4**  
SCALE: 3/4" = 1'-0"

NOTE:  
FOR INFORMATION NOT SHOWN, REF. SECTION 8

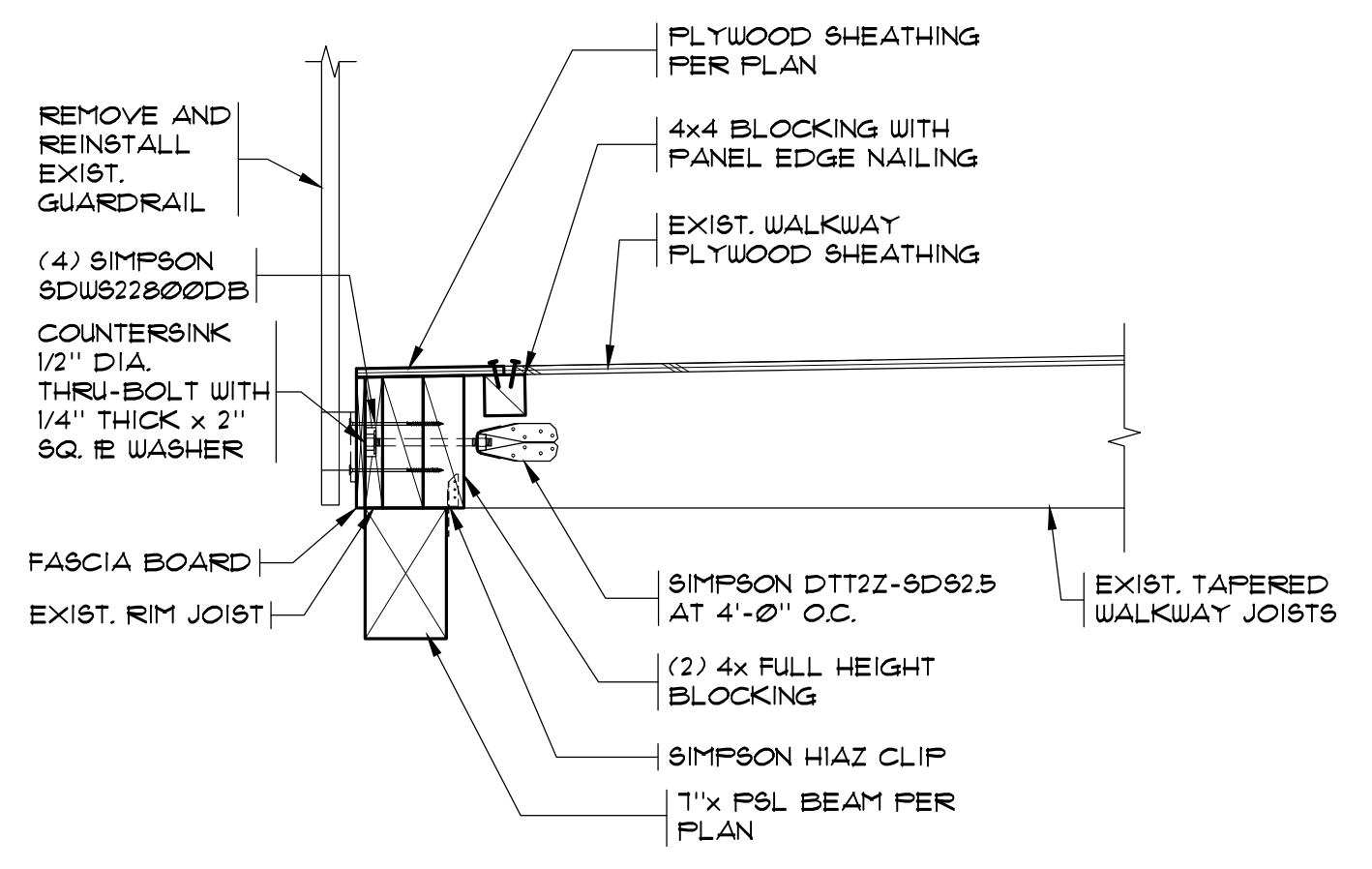

**SECTION 5**  
SCALE: 3/4" = 1'-0"

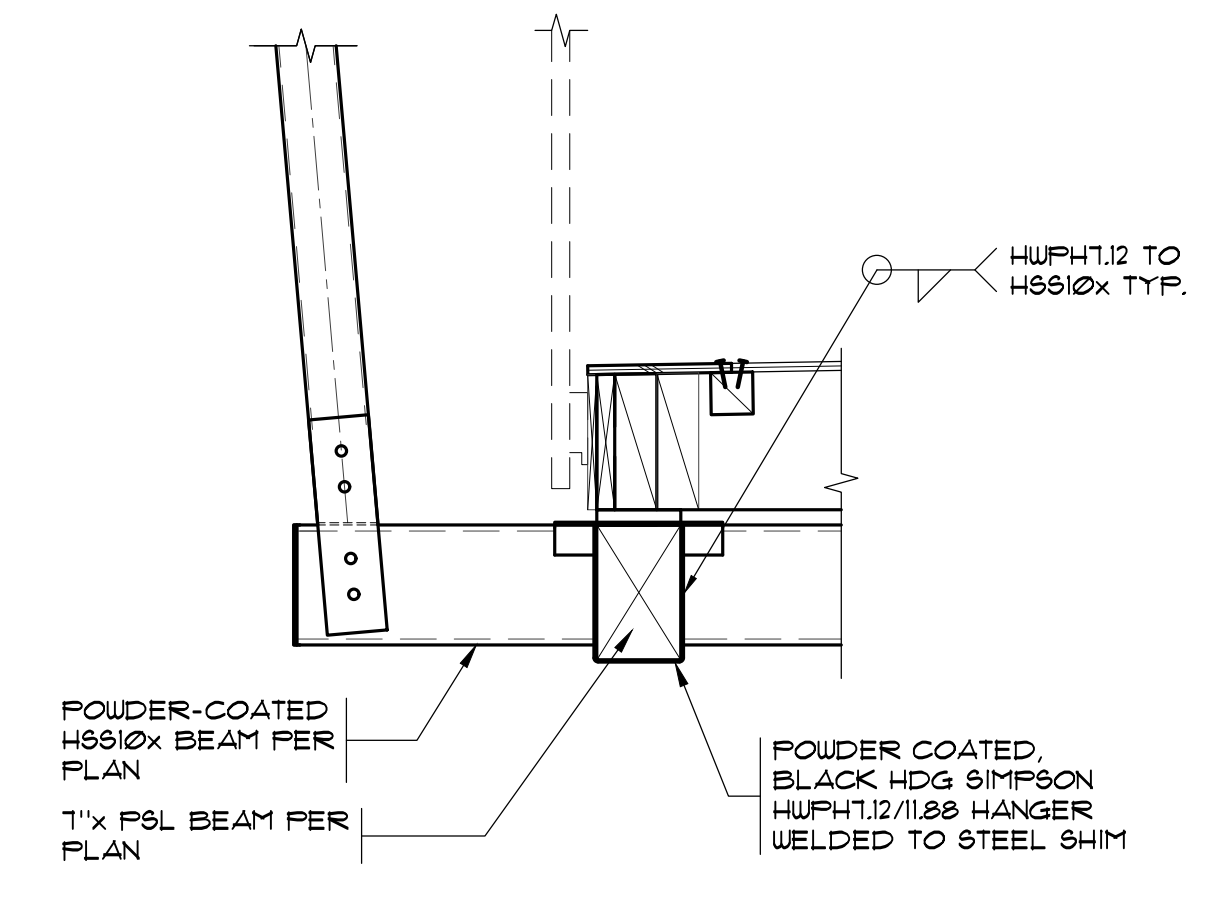

**SECTION 6**  
SCALE: 3/4" = 1'-0"

NOTES:  
• FOR INFORMATION NOT SHOWN, REF. SECTIONS 5 AND 8  
• GRIND STEEL EDGES FOR SMOOTH FINISH  
• BRACE NOT SHOWN FOR CLARITY  
• INSTALL LAF AROUND BEAM PRIOR TO INSTALLATION, REF. ARCH.

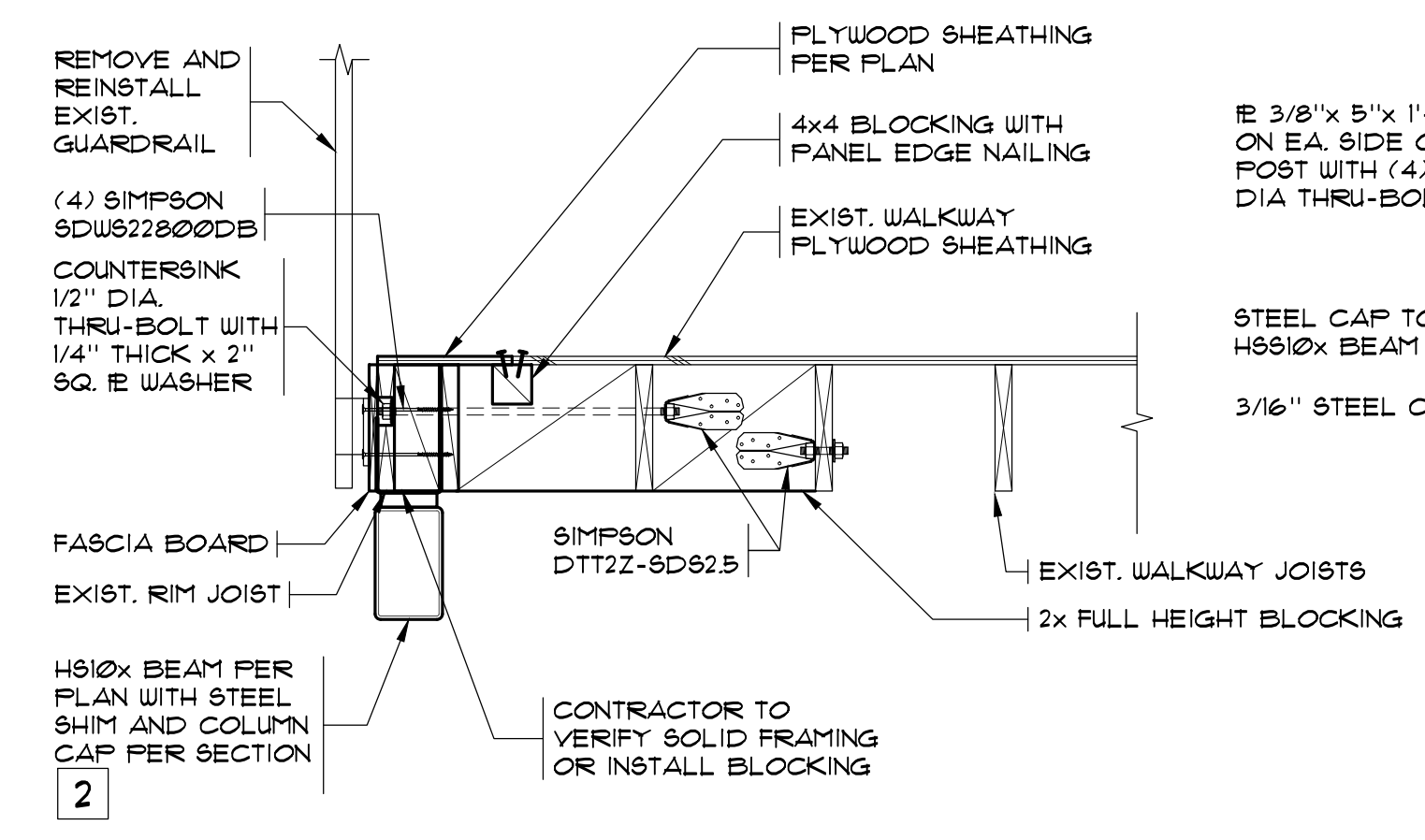

**SECTION 7**  
SCALE: 3/4" = 1'-0"

CONTRACTOR TO VERIFY SOLID FRAMING OR INSTALL BLOCKING

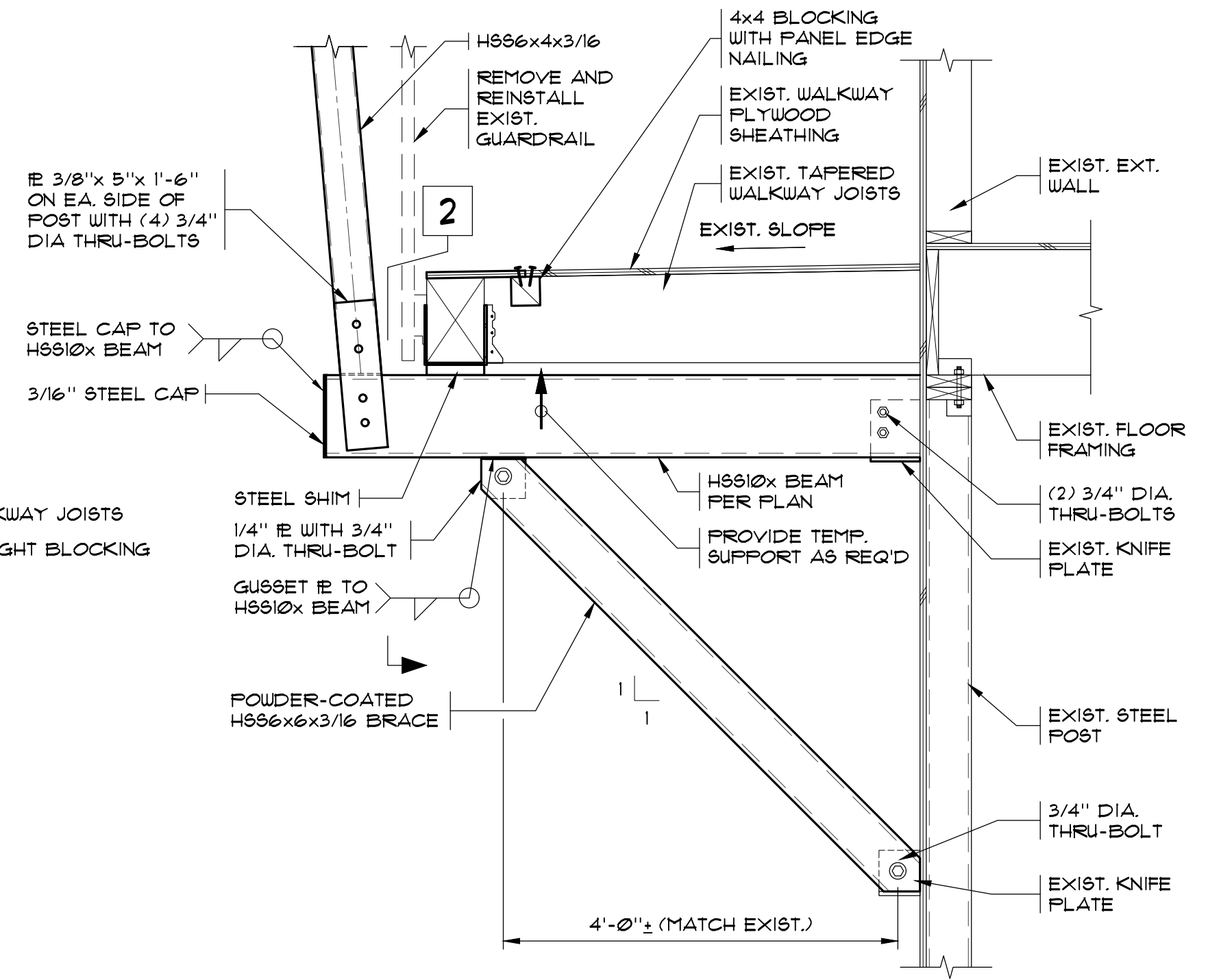

**SECTION 8**  
SCALE: 3/4" = 1'-0"

NOTES:  
• FOR INFORMATION NOT SHOWN, REF. SECTION 2  
• GRIND STEEL EDGES FOR SMOOTH FINISH

Designated	G. MARCONDES	No.	
Drawn	V.H.N.	Revision	BID SET
Checked	C.E.J.	Date	15 AUG, 2025
Approved			



4444 Woodland Park Ave. N. - Suite 100 Seattle, Washington 98103-7199  
[206] 281-7900

Project: GREENBRIDGE APARTMENTS BUILDINGS A, B AND C WALKWAY REPAIR  
9915 11th Ave. SEATTLE, WA

Sheet: S3.0  
Job No. 24200.00

THE INFORMATION PRESENTED ON THESE DRAWINGS IS TO THE LEVEL OF DETAIL FOR CONSTRUCTION COST ESTIMATION ONLY, NOT FOR ACTUAL CONSTRUCTION

**PRELIMINARY**

ALL INFORMATION ON THIS DOCUMENT IS THE EXCLUSIVE PROPERTY OF PACIFIC ENGINEERING TECHNOLOGIES, INC. © COPYRIGHT 2026