

PROJECT MANUAL

PROJECT NAME AND LOCATION:

**ARGYLE APARTMENTS
WINDOW & PATIO DOOR REPLACEMENT**

Contract Number: DW2300531

TABLE OF CONTENTS

02	Invitation to Bid (1 Page)
03	Specifications (27 Pages)
04	Plans (2 Sheets)
05	Instruction to Bidders (6 Pages)
06	General Conditions (15 Pages)
07	Bid Form & Bidder Information (4 Pages) – <i>Return with Bid</i>
08	Sample Contract Form (1 Page)
09	Sample Certificate of Insurance (2 Pages)

INVITATION TO BID

King County Housing Authority (KCHA) will accept bids from qualified general contractors to furnish labor, materials and necessary equipment to perform the following:

SCOPE OF WORK: Work includes, but is not limited to, replacement of existing windows, sliding glass patio doors and trim. and other tasks as described in the bid documents.

PROJECT MANUAL DISTRIBUTION:

Address: King County Housing Authority, 600 Andover Park, Seattle, WA 98188
Distribution: * Documents are available for download on KCHA's website at <http://www.kcha.org/business/construction/open/>

PRE-BID CONFERENCE:

Date and Time: 1/10/2023 at 11:00 A.M.
Jobsite Address: Argyle Apartments, 2517 South 316th Lane, Federal Way, WA 98003.
In Addition: Contractors are strongly encouraged to attend the Pre-Bid Conference. Failure to attend the Conference will not relieve the Contractor of any responsibility for information provided at that time.
For Questions: Questions pertaining to the bid are to be sent via email to MichelleJ@kcha.org no later than seven (7) calendar days prior to bid due date. All responses shall be in the form of Addenda.
Posting: Addenda will be posted on KCHA's website.

BIDS ARE DUE:

Time: **2:00 P.M.**
Date: **January 24, 2023**
Address: King County Housing Authority
600 Andover Park West, Seattle, WA 98188
Submittal Process: * Bids may be sent to Michelle Jackson via email to MichelleJ@kcha.org.
Process: All Bids must be received by KCHA no later than the above due date and time. No Bids will be accepted after that date and time.

BID GUARANTEE: Not Required.

PERFORMANCE AND PAYMENT BONDS: As a condition of award Performance and Payment bonds for 100% of the Contract Award Amount shall be furnished for the Work. On contracts of one hundred fifty thousand dollars (\$150,000.00) or less, at Contractors option the requirement may be waived in lieu of an additional 5% (total 10%) retainage.

KCHA is an Equal Employment Opportunity Employer and strongly encourages minority-owned and women-owned businesses, socially and economically disadvantaged businesses, and small businesses to submit bids or to participate as subcontractors and suppliers on KCHA Contracts.

KCHA reserves the right to reject any or all bids or to waive any informality in the bidding. No bid shall be withdrawn for a period of 60 calendar days subsequent to the opening of the bids without the written consent of KCHA.

CONTACT PERSON: Michelle Jackson at MichelleJ@kcha.org

SPECIFICATIONS

**Argyle Apartments
Window & Patio Door Replacements**

Contract Number: DW2300531
Page 1 of 16

SECTION 01100 - SUMMARY

PART 1 - GENERAL

1.1 WORK COVERED BY CONTRACT DOCUMENTS

A. Project Identification: Window Replacements

1. Project Location: Argyle Apartments, 2517 316th Lane, Federal Way, WA 98003
 - a. Building A – 2528 South 316th Lane , Federal Way; 12 Units, 36 Windows, 12 Sliding Glass Patio Doors
 - b. Building B – 2529 South 316th Lane , Federal Way; 12 units, 36 Windows, 12 Sliding Glass Patio Doors
 - c. Building C – 2525 South 316th Lane , Federal Way; 12 units, 36 Windows, 12 Sliding Glass Patio Doors
 - d. Totals: 108 Windows, 36 Sliding Glass Patio Doors
2. The Work consists of, but is not limited to:
 - a. Removal of existing windows, sliding glass patio doors and trim.
 - b. Trim or add material to ensure that windows and doors meet wraps, sills and countertops, and finished flooring.
 - c. Supply and installation of vinyl windows, sliding glass doors, fasteners, self-adhesive tape, sealant, 5/4” trim and metal flashing.
 - d. Paint trim boards to match existing.
 - e. Repair interior window wraps and sills.

1.2 WORK SEQUENCE

- A. The Work shall be completed in 60 calendar days from the date of Notice to Proceed.
 1. Contractor shall be entitled to an equitable adjustment in the Contract Time for changes in the time of performance directly attributable to severe weather conditions. For additional days to be considered the Contractor shall notify the Owner no later than 8:00 a.m. on each day of a severe weather condition.
- B. Contractor will submit written schedule outlining dates and duration of job including:
 1. Construction start date
 2. Schedule for work in each building
 3. Anticipated final completion date

1.3 LIQUIDATED DAMAGES

SPECIFICATIONS

Argyle Apartments Window & Patio Door Replacements	Contract Number: DW2300531 Page 2 of 16
---	---

- A. Liquidated damages will be assessed for each calendar day that the Contractor exceeds the time for completion in the amount of \$250.

1.4 WORK RESTRICTIONS

- A. Use of the Premises
 - 1. Use of Site: Limit use of premises to work areas. Do not disturb portions of site beyond areas in which the Work is indicated.
 - a. Owner Occupancy: Allow for resident occupancy of site. Owner will occupy site and existing building during entire construction period. Cooperate with Owner during construction operations to minimize conflicts and facilitate resident usage.
 - b. Driveways and Entrances: Keep driveways and entrances serving premises clear and available to residents and emergency vehicles at all times. Do not use these areas for parking or storage of materials.
 - 2. Use of Existing Building: Maintain existing building in a weathertight condition throughout construction period. Repair damage caused by construction operations. Protect property, the buildings and occupants during construction period.
- B. Occupancy Requirements
 - 1. Full Owner Occupancy: Owner and tenants will occupy site and existing building during entire construction period. Cooperate with Owner during construction operations to minimize conflicts and facilitate Owner and tenant usage. Perform the Work so as not to interfere with Owner's operations.

1.5 PERMITS

- A. Contractor is responsible for obtaining and paying for any required permits and for the coordination of all required inspections.
- B. Prepare and file necessary plans, prepare documents and obtain necessary approvals of Authorities Having Jurisdiction (AHJ). Obtain required certificates of inspection for work and deliver to the Owner before request for acceptance and final payment for the work.

1.6 CONTRACT MODIFICATION PROCEDURES

- A. Owner-Initiated Proposal Requests: Architect and/or owner will issue a detailed description of proposed changes in the Work that may require adjustment to the Contract Sum or the Contract Time. If necessary, the description will include supplemental or revised Drawings and Specifications.
- B. Contractor-Initiated Proposals: If latent or unforeseen conditions require modifications to the Contract, Contractor may propose changes by submitting a request for a change.

SPECIFICATIONS

Argyle Apartments Window & Patio Door Replacements

Contract Number: DW2300531
Page 3 of 16

- C. Construction Change Directive: Owner may issue a Construction Change Directive instructing the Contractor to proceed with a change in the Work, for subsequent inclusion in a Change Order for later negotiations on cost.
- D. Documentation: Maintain detailed records required for a change order to be approved and provide evidence of the following:
 - 1. Wage Rates
 - 2. Hours worked for each trade
 - 3. Materials
 - 4. Equipment
- E. Do not perform change order Work without approval of the Owner. Work performed without approval will not be compensated.

1.7 PAYMENT PROCEDURES

- A. Coordinate preparation of the Schedule of Values with preparation of Contractor's Construction Schedule.
- B. Each Application for Payment shall be consistent with previous applications and payments.
- C. Entries shall match data on the Schedule of Values and Contractor's Construction Schedule. Use updated schedules if revisions were made.
- D. Waivers of Lien: With each Application for Payment, submit conditional waivers lien from every entity that is lawfully entitled to file a lien arising out of the Contract and related to the Work covered by the payment.
 - 1. Submit partial waivers on each item for amount requested, before deduction for retainage, on each item.
 - 2. When an application shows completion of an item, submit final or full waivers.
 - 3. Owner reserves the right to designate which entities involved in the Work must submit waivers.
 - a. Submit final Application for Payment with or preceded by final waivers from every entity involved with performance of the Work covered by the application who is lawfully entitled to a lien.
- E. Final Payment Application: Submit final Application for Payment with releases and close out supporting documentation.

1.8 PROJECT MEETINGS

- A. Preconstruction Conference: Schedule a preconstruction conference before starting construction, at a time convenient to Owner, but no later than 7 days after execution of the Agreement.
- B. Progress Meetings: Conduct progress meetings at weekly intervals.

SPECIFICATIONS

**Argyle Apartments
Window & Patio Door Replacements**

Contract Number: DW2300531
Page 4 of 16

1.9 SUBMITTALS

- A. Provide product data for each element of construction and type of product or equipment for approval by Owner.
- B. Subcontract list. Prepare written information that demonstrates capabilities and experience of firm or persons.
- C. Contractors project manager and/or supervisors. Prepare written information that demonstrates capabilities and experience of firm or persons.
 - 1. The Owner will review subcontractors and assigned staff and will accept or reject based on experience or qualifications.
- D. Follow Washington Industrial Safety and Health Act (WISHA) regional directives and provide a site-specific safety program that will require an accident prevention and hazard analysis plan for the contractor and each subcontractor on the work site. The Contractor shall submit a site-specific Accident Prevention Program (APP) to the Owner's representative prior to the initial scheduled construction meeting.

1.10 TEMPORARY FACILITIES

- A. Sanitary Facilities: Provide temporary toilets, wash facilities, and drinking-water fixtures. Comply with regulations and health codes for type, number, location, operation, and maintenance of fixtures and facilities.
- B. Barricades, Warning Signs and Lights: Comply with standards and code requirements for erection of structurally adequate barricades. Paint with appropriate colors, graphics and warning signs to inform personnel and the public of the hazard being protected against.
- C. Use of Owner's existing electric power service will be permitted, as long as equipment is maintained in a condition acceptable to Owner.
- D. Four parking spaces shall be available to the contractor for storage containers and parking. Do not park in marked tenant spaces.

1.11 CONSTRUCTION WASTE MANAGEMENT

- A. Regulatory Requirements: Conduct construction waste management activities in accordance with State of Washington RCW 39.04.13, and all other applicable laws and ordinances.
- B. Performance Requirements
 - 1. General: Where possible divert CDL waste from the landfill by one, or a combination of the following activities: Salvage, Reuse, Source-Separated CDL Recycling, Co-mingled CDL Recycling.
- C. Removal of Construction Waste Management

SPECIFICATIONS

**Argyle Apartments
Window & Patio Door Replacements**

Contract Number: DW2300531
Page 5 of 16

1. Remove CDL waste materials from project site on a regular basis. Do not allow CDL waste to accumulate on-site.
2. Transport CDL waste materials off Owner's property and legally dispose of them.
3. Burning of CDL waste is not permitted.

1.12 EXECUTION REQUIREMENTS

- A. General: Clean Project site and work areas daily, including common areas. Coordinate progress cleaning for joint-use areas where more than one installer has worked. Enforce requirements strictly. Dispose of materials lawfully.

1.13 CUTTING AND PATCHING

A. Quality Assurance

1. Structural Elements: Do not cut and patch structural elements in a manner that could change their load-carrying capacity or load-deflection ratio.
2. Visual Requirements: Do not cut and patch construction in a manner that results in visual evidence of cutting and patching. Do not cut and patch construction exposed on the exterior or in occupied spaces in a manner that would, in Owner's opinion, reduce the building's aesthetic qualities. Remove and replace construction that has been cut and patched in a visually unsatisfactory manner.

B. Performance

1. Cutting: Cut existing construction by sawing, drilling, breaking, chipping, grinding, and similar operations, including excavation, using methods least likely to damage elements retained or adjoining construction. If possible, review proposed procedures with original Installer; comply with original Installer's written recommendations.
2. Patching: Patch construction by filling, repairing, refinishing, closing up, and similar operations following performance of other Work. Patch with durable seams that are as invisible as possible. Provide materials and comply with installation requirements specified in other Sections of these Specifications.
 - a. Exposed Finishes: Restore exposed finishes of patched areas and extend finish restoration into retained adjoining construction in a manner that will eliminate evidence of patching and refinishing.
 - b. Exterior Building Enclosure: Patch components in a manner that restores enclosure to a weathertight condition.

1.14 CLOSEOUT PROCEDURES

- A. General: Provide final cleaning. Conduct cleaning and waste-removal operations to comply with local laws and ordinances and Federal and local environmental and antipollution regulations.

SPECIFICATIONS

**Argyle Apartments
Window & Patio Door Replacements**

Contract Number: DW2300531
Page 6 of 16

1. Prior to acceptance of the work at each building, clean project site, yard, and grounds, in areas disturbed by construction activities, including landscape development areas, of rubbish, waste material, litter, and other foreign substances.

- B. Prior to final acceptance and final payment, Contractor shall submit a written warranty covering labor and materials for a period of one (1) year from final completion.

PART 2 - PRODUCTS (Not Used)

PART 3 - EXECUTION (Not Used)

END OF SECTION 01100

SPECIFICATIONS

**Argyle Apartments
Window & Patio Door Replacements**

Contract Number: DW2300531
Page 7 of 16

SECTION 01732 - SELECTIVE DEMOLITION

PART 1 - GENERAL

1.1 SUMMARY

- A. This Section includes demolition, and removal and replacement.
 - 1. Selected portions of a building or structure to be demolished include but are not limited to:
 - a. All windows, patio sliders and trim.
 - b. Cut back existing liners and sills as necessary.
 - c. Cut back countertops as necessary.

1.2 MATERIALS OWNERSHIP

- A. Except for items or materials indicated to be reused, salvaged, reinstalled, or otherwise indicated to remain Owner's property, demolished materials shall become Contractor's property and shall be removed from Project site.

1.3 PROJECT CONDITIONS

- A. Owner will occupy portions of building immediately adjacent to selective demolition area. Conduct selective demolition so Owner's operations will not be disrupted. Provide not less than 72-hours' notice to Owner of activities that will affect Owner's operations.
- B. Maintain access to existing walkways, corridors, and other adjacent occupied or used facilities.
 - 1. Do not close or obstruct walkways, corridors, or other occupied or used facilities without written permission from authorities having jurisdiction.
- C. Owner assumes no responsibility for condition of areas to be selectively demolished.
 - 1. Conditions existing at time of inspection for bidding purpose will be maintained by Owner as far as practical.
- D. Hazardous Materials: Argyle Apartments were originally constructed in 1984.
 - 1. It is not expected that hazardous materials will be encountered in the Work.
 - 2. If other materials suspected of containing hazardous materials are encountered, do not disturb; immediately notify Owner.
- E. Storage or sale of removed items or materials on-site will not be permitted.
- F. Utility Service: Maintain existing utilities indicated to remain in service and protect them against damage during selective demolition operations.

SPECIFICATIONS

PART 2 - PRODUCTS

2.1 REPAIR MATERIALS

- A. Use repair materials identical to existing materials.
 - 1. If identical materials are unavailable or cannot be used for exposed surfaces, use materials that visually match existing adjacent surfaces to the fullest extent possible.
 - 2. Use materials whose installed performance equals or surpasses that of existing materials.

PART 3 - EXECUTION

3.1 EXAMINATION

- A. Verify that utilities have been disconnected and capped.
- B. Survey existing conditions and correlate with requirements indicated to determine extent of selective demolition required.

3.2 UTILITY SERVICES

- A. Existing Utilities: Maintain services indicated to remain and protect them against damage during selective demolition operations.

3.3 PREPARATION

- A. Site Access and Temporary Controls: Conduct selective demolition and debris-removal operations to ensure minimum interference with roads, streets, walks, walkways, and other adjacent occupied and used facilities.
 - 1. Do not close or obstruct streets, walks, walkways, or other adjacent occupied or used facilities without permission from Owner and authorities having jurisdiction. Provide alternate routes around closed or obstructed traffic ways if required by governing regulations.
 - 2. Erect temporary protection, such as walks, fences, railings, canopies, and covered passageways, where required by authorities having jurisdiction.
 - 3. Protect existing site improvements, appurtenances, and landscaping to remain.

3.4 SELECTIVE DEMOLITION

SPECIFICATIONS

**Argyle Apartments
Window & Patio Door Replacements**

Contract Number: DW2300531
Page 9 of 16

- A. General: Demolish and remove existing construction only to the extent required by new construction and as indicated. Use methods required to complete the Work within limitations of governing regulations.
- B. Removal and installation of new items: Remove and install items as soon as possible to prevent unsafe conditions. Close up all openings at the end of each day by completing the window or door installations. Do not remove existing windows or doors if unable to complete the installation by the end of the work day.

3.5 DISPOSAL OF DEMOLISHED MATERIALS

- A. General: Promptly dispose of demolished materials. Do not allow demolished materials to accumulate on-site.
- B. Burning: Do not burn demolished materials.
- C. Disposal: Transport demolished materials off Owner's property and legally dispose of them.

END OF SECTION 01732

SPECIFICATIONS

SECTION 08531 – VINYL WINDOWS

PART 1 - GENERAL

1.1 SUMMARY

- A. Section Includes: Operable Extruded Vinyl (PVC) Horizontal Sliding Windows and Sliding Patio Doors

1.2 SUBMITTALS

- A. Product Data: Provide manufacturer's standard details and catalog data demonstrating compliance with referenced standards; include installation instructions and storage requirements.
 - 1. Quality Assurance/Control Submittals:
 - a. Qualifications: Proof of manufacturer's qualifications.
 - b. U-Factor and structural rating test data.
 - c. Manufacturer's Installation Instructions.
- B. Closeout Submittals: Submit following items:
 - 1. Temporary labels marked to identify windows that labels were applied to.
 - 2. Maintenance instructions.
 - 3. Special Warranties.

1.3 QUALITY ASSURANCE

- A. Overall Standards: Comply with AAMA/WDMA/CSA 101/I.S.2/A440-05 except as otherwise noted herein.
- B. Qualifications:
 - 1. Manufacturer Qualifications:
 - a. Certified Manufacturer by AAMA, and NFRC.
- C. Certifications for insulated glass windows:
 - 1. AAMA: Windows shall be Gold Label certified with label attached to frame per AAMA requirements.
 - 2. NFRC: Windows shall be NFRC certified with temporary U-factor label applied to glass and an NFRC tab added to permanent AAMA frame label.
- D. Mock-up

SPECIFICATIONS

**Argyle Apartments
Window & Patio Door Replacements**

Contract Number: DW2300531
Page 11 of 16

1. Install window mock-up using approved assembly including fasteners, flashing, tape, sealants and related accessories in accordance with the drawings and specifications, and manufacturer's current printed instructions and recommendations.
 - a. Mock-up location: As selected by Owner.
 - b. Coordinate installation with Owner and give a minimum of one week's notice prior to installation.
 - c. Mock-up may remain as part of the work.

1.4 DELIVERY, STORAGE AND HANDLING

- A. Follow manufacturer's instructions on label applied to windows.

1.5 WARRANTY

- A. Commercial Special Warranty:
 1. 10 year guarantee.
 2. Guarantee windows against defects in materials and workmanship for ten years on glass and material including parts and labor.

PART 2 - PRODUCTS

2.1 MANUFACTURER

- A. Ply Gem Windows, 5001 D Street NW, Auburn, WA 98001 Tel. (800) 227-3699.
www.certainteed.com.

2.2 MATERIALS

- A. Window Frame and Sash Members: Impact resistant, exterior grade polyvinyl chloride extrusions complying with AAMA 303 and ASTM D 4726.
 1. Non-corroding, non-flaking, non-chipping, non-rotting; no electrical conductance; low thermal conductance
 2. Minimum External Wall Thickness: 0.070 inch nominal.
 3. Finish of Surfaces Exposed to View: Solid vinyl with smooth gloss finish and uniform consistent color.
- B. Insulating Unit: Complying with ASTM E 774, Class CBA.
 1. Thermal Performance:
 - a. Total Unit U-Value: 0.30
 - b. Visible Transmittance: 0.55
 - c. Solar Heat Gain Coefficient: 0.29

SPECIFICATIONS

Argyle Apartments
Window & Patio Door Replacements

Contract Number: DW2300531
Page 12 of 16

- C. Screens: Type installable from interior side, providing reasonable insect control (only) when operable sash is in open position; re-wirable glass fiber mesh, 14 x 18 mesh, secured in channel of aluminum box frame with continuous vinyl spline.
 - 1. Frame Color: Matching frame and sash interior color.
- D. Operating Hardware: Types for specified operable-sash windows; sight-exposed hardware of UV-stabilized engineered plastic; color matched to vinyl extrusions for uniform appearance. Die cast zinc cam-type sash locks and keepers, color matched to vinyl extrusions for uniform appearance.
- E. Fasteners: Corrosion-resistant.
- F. Weatherstripping: Types for specified operable windows and operable doors.
- G. Mullions: Structural mullion system complying with AAMA Grade deflection requirements for supported windows; extruded aluminum core; internal and external rigid PVC caps color to match adjacent window frames.

2.3 GENERAL PERFORMANCE REQUIREMENTS

- A. Thermal Performance: Comply with NFRC 100.
- B. Air Leakage, Water Resistance, Structural Test: Comply with AAMA/WDMA/CSA 101/I.S.2/A440-05
- C. Forced-Entry Resistance: Comply with CAWM 301 and ASTM F588

2.4 HORIZONTAL SLIDING WINDOWS

- A. Acceptable Product: Pro Series 200 Slider.
 - 1. Frame and Sash Construction: Mitered and fusion-welded corners; integral 1-inch pre-punched nailing fin four sides; integral weep system; integral glazing provision; molded-in glide rail; operable sash interlocks to the staybar; one operable sash, one fixed lite.
 - 2. Factory Glazing:
 - a. Super spacer
 - b. Argon Fill
 - c. HP Low E
 - d. Glass thickness: SS
 - 3. Operating Hardware:
 - a. Locks: Cam-type sash lock and keeper meeting forced entry resistance requirements of CAWM 301, engineered to force meeting stiles/rails, with interlock for minimum air infiltration.
 - b. Rollers: Adjustable brass rollers.

SPECIFICATIONS

Argyle Apartments Window & Patio Door Replacements

Contract Number: DW2300531
Page 13 of 16

4. Weatherstripping: High-density polypropylene pile, with polypropylene fin, meeting AAMA 701.
5. Screens: Frame color matching window frame and sash interior color.
6. Styles and Sizes: To fit existing rough opening.
7. Operable window: Match existing.

2.5 FIXED WINDOWS

A. Acceptable Product: Pro Series.

1. Frame and Sash Construction: Mitered and fusion-welded corners; integral 1-inch pre-punched nailing fin four sides.
2. Factory Glazing:
 - a. Super spacer
 - b. Argon Fill
 - c. HP Low E
 - d. Glass thickness: Tempered DD
3. Styles and Sizes: To fit existing rough opening.

2.6 PATIO DOORS

A. Acceptable Product: Pro Series 960 Sliding Patio Door

1. Frame and Panel Construction:
 - a. Mitered and fusion-welded corners; integral 1-inch pre-punched nailing fin four sides; integral weep system; integral J channel (severable) that accepts up to 13/16 inch exterior cladding; integral glazing provision.
 - b. Standard or French style panels; reinforced stiles; interlocking meeting stiles.
 - c. Fixed Units: Frame profile matching operable units; fixed insulating glazing unit secured in integral glazing provision in panel.
2. Factory Glazing:
 - a. Super spacer
 - b. Argon Fill
 - c. HP Low E
 - d. Glass thickness: Tempered DD
3. Operating Hardware:
 - a. Roller Track: Extruded rigid vinyl with stainless steel cap.
 - b. Rollers: Adjustable tandem stainless steel rollers.
 - c. Stops: Anti-lift, preventing operable sash to be removed from exterior.

SPECIFICATIONS

Argyle Apartments Window & Patio Door Replacements

Contract Number: DW2300531
Page 14 of 16

- d. Locks: Single-lever actuated two-point locking; catch at locking points, meeting forced entry resistance requirements of CAWM 301; lock key-actuated from exterior; white or tan baked enamel handle.
- e. Locks: Single-lever actuated four-point locking; catch at locking points, meeting forced entry resistance requirements of CAWM 301; lock key-actuated from exterior; white or tan baked enamel handle.

- 4. Color: White.
- 5. Weatherstripping: Double-row high-density polypropylene pile, with polypropylene fin, meeting AAMA 701.
- 6. Screens: Frame color matching patio door frame and panel interior color.
- 7. Styles and Sizes: To fit existing rough opening.
- 8. Operable window: Match existing.

2.7 FINISH

- A. Frame and Panel Color: White
- B. Color match screen frame to frame and panel color and Exterior color matched screen to frame and panel color.

2.8 FLASHING

- A. Self-adhesive flashing tape - 3M™ All weather Flashing Tape 8067.
- B. Sheet metal head flashing with hem to leading edge.

2.9 SEALANTS

- A. Non-expanding foam.
- B. Silicon sealant to embed head flashing.
- C. Tremco caulk and backerrod.
- D. Paintable caulk to interior.

2.10 TRIM BOARDS

- A. Trim: Primed FiberCement: 5/4-inch material.
- B. See Window Replacement Detail Sheet for details.

2.11 PAINT

SPECIFICATIONS

**Argyle Apartments
Window & Patio Door Replacements**

**Contract Number: DW2300531
Page 15 of 16**

- A. Primer and exterior paint as recommended by Sherwin Williams to match existing finish in color and sheen.

PART 3 - EXECUTION

3.1 EXAMINATION

- A. Examine openings, substrates, structural support, anchorage, and conditions, with Installer present, for compliance with requirements for installation tolerances and other conditions affecting performance of work. Verify rough opening dimensions, levelness of sill plate, and operational clearances. Examine wall flashings, vapor retarders, water and weather barriers, and other built-in components to ensure a coordinated, weather tight window installation.
 - 1. Verify that fasteners in framed walls are fully driven and will not interfere with window installation.
 - 2. Verify that sill is flat and level.
- B. Thoroughly clean all areas after removal of window including remove all caulk and sealant.
- C. Coordinate with responsible entity to correct unsatisfactory conditions.
- D. Commencement of work by installer is acceptance of substrate conditions.
- E. Note: Ensure that new kitchen windows are sized to cover the edge of the counter top.

3.2 WINDOW INSTALLATION

- A. Flash head in accordance as indicated in these specifications and plans and in accordance with industry standards, manufacturer's recommendations.
 - 1. Adjust GWB liner, wood sills and kitchen counter tops as necessary including either cutting back or extending to match existing.
 - 2. Install self-adhesive flashing tape to head, sills and jambs.
 - 3. Apply sealant as indicated.
 - 4. Install head flashing as indicated on plans.
 - 5. Caulk interior lining.
 - 6. Remove and reinstall blinds if necessary.

3.3 TRIM BOARDS

- A. Install trim boards as indicated.
- B. Set nails and caulk ready for paint.

3.4 ADJUSTING

SPECIFICATIONS

**Argyle Apartments
Window & Patio Door Replacements**

Contract Number: DW2300531
Page 16 of 16

- A. Adjust operating sashes and ventilators, screens, hardware, and accessories for a tight fit at contact points and weather stripping for smooth operation and weather tight closure. Lubricate hardware and moving parts if necessary.

3.5 CLEANING

- A. Remove temporary labels and retain for Closeout Submittals.
- B. Clean factory-glazed glass immediately after installing windows. Clean soiled surfaces and glass using a mild detergent and warm water solution with soft, clean cloths. Remove nonpermanent labels, and clean surfaces.
- C. Install insect screens on operable panels.

3.6 PAINT

- A. Trim shall be primed and painted according to the manufacturer's instructions to match existing finish.

END OF SECTION 08531

SPECIFICATIONS

Argyle Apartments

Windows & Patio Door Replacement

09911- EXTERIOR PAINTS AND COATINGS

PART 1 - GENERAL

1.1 SECTION INCLUDES

- A. Surface preparation and field painting of exposed exterior items and surfaces.

1.2 REFERENCES

- A. ASTM D 16 - Standard Terminology Relating to Paint, Varnish, Lacquer, and Related Products.
- B. ASTM D 3359 - Standard Test Methods for Measuring Adhesion by Tape Test.
- C. ASTM D 1653 - Standard Test Methods for Water Vapor Transmission of Organic Coating Films.
- D. ASTM E-96 - Standard Test Methods for Water Vapor Transmission of Materials.
- E. SSPC, The Society for Protective Coatings - Web Site <http://www.sspc.org>:
 - 1. SSPC-SP1 Solvent Cleaning.
 - 2. SSPC-SP2 Hand Tool Cleaning.
 - 3. SSPC-SP3 Power Tool Cleaning.
 - 4. SSPC-SP7 Brush-Off Blast Cleaning.
- F. PDCA Paint and Decorating Contractors of America - Web Site <http://www.pdca.org>:
 - 1. PDCA Standards P1 through P15

1.3 SUBMITTALS

- A. Product Data: Manufacturer's data sheets on each product to be used, including:
 - 1. Preparation instructions and recommendations.
 - 2. Storage and handling requirements and recommendations.
 - 3. Installation methods.
- B. Finish Schedule: Submit finish schedule including color information, gloss and model number for each type and color of finish specified.
- C. Verification Samples: For each finish product specified, two samples, minimum size 6 inches square, representing actual product, color, and patterns.

1.4 QUALITY ASSURANCE

- A. Manufacturer Qualifications: All primary products specified in this section will be supplied by a single manufacturer with a minimum of ten years' experience.

SPECIFICATIONS

Argyle Apartments

Window & Patio Door Replacement

- B. Installer Qualifications: All products listed in this section are to be installed by a single installer with a minimum of five years demonstrated experience in installing finishes and coatings of the same type and scope as specified.
- C. Mock-Up: Provide a mock-up for evaluation of surface preparation techniques, color, sheen and application workmanship.
 - 1. Finish areas designated by Owner.
 - 2. Finish one 8' x 4' area for each color.
 - 3. Finish two exterior doors for adhesion test purposes.
 - 4. Do not proceed with remaining work until workmanship, color, and sheen are approved by Owner.
 - 5. Refinish mock-up area as required to produce acceptable work.
 - 6. Provide up to three color change mock ups.
- D. Minimum Specifications: If instructions contained in this specification, bid documents or painting schedule are at variance with the paint manufacturer's instructions or the applicable standard, and codes listed, surfaces shall be prepared and painted to suit the higher standard, as determined by Sherwin-Williams, the customer or management representative.
- E. Resolution of Conflicts: Contractor shall be responsible for stopping work and request prompt clarification when instructions are lacking, when conflicts occur in the specifications and/or paint manufacturer's literature, or the procedures specified are not clearly understood. Any questions concerning these specifications should be clarified prior to commencing the job. Any changes to these specifications would require written approval by Sherwin-Williams, the customer or customer's representative.
- F. Safety: All pertinent safety regulations shall be adhered to rigidly. In addition, all safety noted on the manufacturer's Product Data Sheets and labels shall be observed. Material Safety Data Sheets and Product Data Sheets are available from your local Sherwin-Williams store or representative or by visiting www.sherwin-williams.com.
- G. Jobsite Visitation
 - 1. The Contractor shall be responsible for visiting the jobsite and familiarizing himself with the job and working conditions.
 - 2. All work during application is subject to inspection by the owner or his representative.
 - 3. It will be the Contractor's responsibility to own and use a wet film thickness gauge to check the application thickness as he proceeds.
 - 4. Contractor has complete responsibility for ensuring that the project specifications are followed, notwithstanding periodic visits to the project by a Sherwin-Williams representative.
 - 5. Any questions concerning these specifications should be clarified prior to commencing work. Any changes to these specifications would require written approval of the Sherwin-Williams representative.

1.5 DELIVERY, STORAGE, AND HANDLING

- A. Store products in manufacturer's unopened packaging until ready for installation.
- B. Store and dispose of solvent-based materials, and materials used with solvent-based materials, in accordance with requirements of local authorities having jurisdiction.

SPECIFICATIONS

Argyle Apartments

Window & Patio Door Replacement

- C. Take special safety precautions against hazards from toxic and flammable materials.
- D. Place paint and solvent contaminated cloths and materials, subject to spontaneous combustion, in containers and remove from job site each day.
- E. Keep open flame, electrical and static spark, and other ignition sources from flammable vapors and materials at all times.

1.6 PROJECT CONDITIONS

- A. Maintain environmental conditions (temperature, humidity, and ventilation) within limits recommended by manufacturer for optimum results. Do not install products under environmental conditions outside manufacturer's recommended limits.
- B. Post "WET PAINT" signs during application and curing of all coatings that may be accessed by other trades or the public.
- C. Post "NO SMOKING" signs during application and curing of solvent-based materials.

1.7 COORDINATION

- A. Coordinate Work with other operations and installation of finish materials to avoid damage to installed materials. Coordinate with the paint representative, Management Company and Owner.
- B. Do not apply coating materials until moisture or dust-producing work or other appearance or performance impairing construction activities have been completed.

1.8 WARRANTY

- A. At project closeout, provide to Owner an executed copy of the manufacturer's standard 7-10 year warranty against manufacturing defect, outlining its terms, conditions, and exclusions from coverage. Warranty shall be provided by the manufacturer specifically identifying the property and products applied.
 - 1. Include final written approval from paint manufacturer's representative that the product has been applied in accordance with the manufacturer's instructions as required to obtain manufacturer's standard limited warranty.
 - 2. Submit a coating maintenance manual, "Project Color and Product Information" report. Manual shall include an Area Summary with finish schedule, Area Detail designating where each product/color/finish was used, product data pages, Material Safety Data Sheets, care and cleaning instructions, touch-up procedures, and color samples of each color and finish used.
- B. Contractor shall submit a written warranty covering labor and materials for a period of two (2) years from the date of final completion.

PART 2 - PRODUCTS

2.1 MATERIALS

EXTERIOR PAINTS AND COATINGS

09911 - 3

SPECIFICATIONS

Argyle Apartments

Window & Patio Door Replacement

- A. All materials specified are from The Sherwin-Williams Company.
- B. All paints shall be delivered to the job site in the original container with the manufacturer's label intact.
- C. The paint shall be used and applied per label and data sheet instructions. The material shall not be thinned or modified in any way unless specified herein. Manufacturer's recommendation for proper surface preparation shall be followed. All data sheets on specified materials are available from your local Sherwin-Williams representative or <http://www.paintdocs.com/>.
- D. All paint and sundries at the job site shall be available for inspection at any time upon commencement of the job by the owner, owner's agent, or a Sherwin-Williams representative.
- E. Unsuitability of specified products: Claims concerning unsuitability of any material specified or inability to satisfactorily produce the work will not be entertained, unless such claim is made in writing to Owner before work is started.
- F. Number of coats scheduled is minimum. Apply additional coats at no additional cost if necessary to completely hide base materials, produce uniform color, and provide satisfactory finish result.

2.2 MANUFACTURERS

- A. Acceptable Manufacturer: The Sherwin-Williams Company
 - 1. Representative – Andrew Dickson
Phone: 253-258-1560
Email: andrew.dickson@sherwin.com

PART 3 - EXECUTION

3.1 EXAMINATION

- A. Examine surfaces scheduled to receive paint and finishes for conditions that will adversely affect execution, permanence or quality of work and which cannot be put into acceptable condition through preparatory work. Notify Owner in writing of any defects or conditions which will prevent a satisfactory installation.
- B. Examine surfaces scheduled to be finished prior to commencement of work. Report any condition that may effect proper application.
- C. Maximum Moisture Content of Substrates: When measured with an electronic moisture meter as follows;
 - 1. Concrete: 12 percent
 - 2. Portland Cement Plaster and Stucco: 12 percent
 - 3. Masonry (Clay and CMU): 12 percent
 - 4. Wood: 15 percent
 - 5. Gypsum Board: 12 percent

SPECIFICATIONS

Argyle Apartments

Window & Patio Door Replacement

- D. Verify suitability of substrates, including surface conditions and compatibility with existing finishes and primers.
- E. Proceed with surface preparation and coating application only after unsatisfactory conditions have been corrected.
 - 1. Application of coating is construed as acceptance of surfaces and conditions.

3.2 PREPARATION

- A. Clean surfaces thoroughly prior to coating application.
- B. Masking: All masking over windows in occupied units shall be removed at the end of each work day.
- C. Do not start work until surfaces to be finished are in proper condition to produce finished surfaces of uniform, satisfactory appearance.
- D. Stains and Marks: Remove completely, if possible, using materials and methods recommended by coating manufacturer; cover stains and marks which cannot be completely removed with isolating primer or sealer recommended by coating manufacturer to prevent bleed-through.
- E. Remove Mildew, Algae, and Fungus using materials and methods recommended by coating manufacturer.
- F. Remove dust and loose particulate matter from surfaces to receive coatings immediately prior to coating application.
- G. Remove or protect adjacent hardware, electrical equipment plates, mechanical grilles and louvers, lighting fixture trim, fabric canopies, and other items not indicated to receive coatings.
- H. Move or protect equipment and fixtures adjacent to surfaces indicated to receive coatings to allow application of coatings.
- I. Protect adjacent surfaces not indicated to receive coatings.
- J. Prepare surfaces in accordance with manufacturer's instructions for specified coatings and indicated materials, using only methods and materials recommended by coating manufacturer.

3.3 SURFACE PREPARATION

- A. Each surface shall be cleaned, scraped, sanded and prepared as specified. Should any surface be found unsuitable to produce a proper paint or sealant finish, the paint representative shall be notified, in writing, and no materials shall be applied until the unsuitable surfaces have been made satisfactory. Commencing of work in a specific area shall be construed as acceptance of surfaces and thereafter as fit and proper to receive finish.
- B. Pressure wash or water blast to remove oil, grease, dirt, loose mill scale and loose paint by water at pressures of 2500-3000 p.s.i. Power tool clean per SSPC-SP3 to remove loose rust and mill scale. Hand tool clean per SSPC- SP2 and sand all glossy surfaces to promote adhesion.
- C. Remove all dirt, mildew, peeling paint, chalk and any foreign materials detrimental to the new finish.

SPECIFICATIONS

Argyle Apartments

Window & Patio Door Replacement

- D. Mildew: Remove before painting by washing with a solution of 1-part liquid bleach and 3 parts water. Apply the solution and scrub the mildewed area. Allow the solution to remain on the surface for 10 minutes. Rinse thoroughly with water and allow the surface to dry before painting. Do not add detergents or ammonia to the bleach/water solution.
- E. All deteriorated or delaminated substrates shall be replaced with new materials. New substrates will be box primed (6 sides) before installation in accordance with specifications. Delaminating substrate is defined as a substrate surface that paint is being applied to lifting or peeling away from the previous coating/s or original substrate/s.
- F. Metal: Pressure wash and then sand, wire brush, or scrape as necessary to remove excess rust scale and loose/peeling paint not removed initial cleaning. Prime all bare metal as soon as possible after preparation.
- G. All other surfaces: Pressure wash and scrape to remove dirt contaminants, dust, and loose/peeling paint to provide a smooth surface for paint application. Hammer all protruding nail heads flush with surface before painting. Prime all bare wood areas before applying finish coat. Caulk any open miters or cracks in surface.
- H. Any debris or chemical residue on windows due to power wash operation will be removed by thoroughly rinsing the windows and surrounding trim. Due care is to be exercised around window seals to prevent damage. Protect all vehicles, other surfaces or plants which will not be receiving paint but which might be harmed by chemical exposure. Temporary coverings are normally the preferred method.
- I. All washed surfaces will have at least two days of continuous drying time (no rain). Surfaces to be painted must have no more than 13% moisture content before priming and painting commences. Washing one day and painting the next is not acceptable.
- J. The Owner's Representative and paint manufacturer's representative shall inspect preparation prior to the application of paint finishes. Contractor will rework surfaces not properly prepared to receive paint finishes to the satisfaction of the either.

3.4 APPLICATION - GENERAL

- A. Weather: All materials are to be applied in accordance with the product data page in regards to weather conditions. Stop exterior work early enough in the day to permit paint film to set up before condensation caused by night temperature drops occurs. Do not begin painting until surfaces are moisture free.
- B. Remove and protect hardware, accessories, device plates, lighting fixtures, factory finished work and similar items or provide ample in-place protection. Upon completion of each space, carefully replace all removed items. Cover all electrical panel box covers and doors before painting walls. Omit if covers have been previously painted.
- C. Remove dust and other foreign materials from substrate immediately prior to applying each coat.
- D. Apply each coat to uniform coating thickness in accordance with manufacturer's instructions, not exceeding manufacturer's specified maximum spread rate for indicated surface; thins, brush marks, roller marks, orange-peel, or other application imperfections are not permitted.

SPECIFICATIONS

Argyle Apartments

Window & Patio Door Replacement

- E. Allow manufacturer's specified drying time, and ensure correct coating adhesion, for each coat before applying next coat.
- F. Inspect each coat before applying next coat; touch-up surface imperfections with coating material, feathering, and sanding if required; touch-up areas to achieve flat, uniform surface without surface defects visible from 5 feet.
- G. Do not apply succeeding coat until Owner and paint manufacturer's representative has approved previous coat; only approved coats will be considered in determining number of coats applied.
- H. Where coating application abuts other materials or other coating color, terminate coating with a clean sharp termination line without coating overlap.
- I. Where color changes occur between adjoining spaces, through framed openings that are of same color as adjoining surfaces, change color at outside top corner nearest to face of closed door.
- J. Re-prepare and re-coat unsatisfactory finishes; refinish entire area to corners or other natural terminations.
- K. Contractor shall protect his/her work at all times and shall protect all adjacent work and materials by suitable covering or other method during progress of the work. Upon completion of work, he/she shall remove all paint and varnish spots from floors, glass and other surfaces. He shall remove from premises all rubbish and accumulated materials of whatever nature not caused by others and shall leave his part of work in a clean, orderly, and acceptable condition.
- L. Materials shall be applied under adequate illumination, evenly spread and flowed on smoothly to avoid runs, sags, holidays, brush marks, air bubbles and excessive roller stipple. The finished paint film should be a consistent color and sheen to provide a uniform appearance.
- M. All repairs, replacements and applications are to meet or exceed all manufacturers' and attached specifications.
- N. Coverage and hide shall be complete, through approved methods of application by airless sprayer, brush and roller cover. When color, stain, dirt, or undercoats show through final coat of paint, surface shall be covered by additional coats until paint film is of uniform finish, color, appearance and coverage (regardless of the number of coats specified).
- O. Exterior Doors
 - 1. Exterior doors shall be painted in groups that allow a single Owner provided staff member to monitor for security.
 - 2. Doors shall be painted open and shall include painting of the hinge side (do not paint hinges or labels).
 - 3. Remove weather stripping prior to painting doors to ensure that doors may be secure immediately after painting.
 - 4. Replace weather stripping when dry.

3.5 APPLICATION – CONDITIONS & WORKMANSHIP

- A. Keep surface dust, dirt and debris free before, during, and after painting, until paint is cured.

SPECIFICATIONS

Argyle Apartments

Window & Patio Door Replacement

- B. Execute work in accordance with label directions. Coating application shall be made in conformance to this specification and to the manufacturer's paint instruction on the labels and Product Data Sheets.
- C. All work shall be accomplished by persons with the necessary skill and expertise and qualified to do the work in a competent and professional manner.
- D. All shrubbery, outside carpeting, sprinkler systems, and cars, shall be fully protected against damage during each stage of the painting project.
- E. Owner shall provide water and electricity from existing facilities.
- F. Normal safety and "wet paint" signs, necessary lighting and temporary roping off around work areas shall be installed and maintained in accordance with OSHA requirements while the work is in progress.
- G. A progress schedule shall be furnished by the contractor to the owner for approval and shall be based on the contract completion date. Contractor shall advise the owner of those areas in which work is to be performed sufficiently in advance of the work schedule to permit the owner to prepare for the work, advise residents, move vehicles, etc.
- H. Do not paint over any code required labels or any equipment identification, performance rating, name or nomenclature plates.
- I. Coverage and hide shall be complete. When color, stain, dirt, or undercoats show through final coat of paint, surface shall be covered by additional coats until paint film is of uniform finish, color, appearance and coverage (regardless of the number of coats specified).

3.6 CLEANING

- A. Clean excess coating materials, and coating materials deposited on surfaces not indicated to receive coatings, as construction activities of this section progress; do not allow to dry.
- B. Re-install hardware, electrical equipment plates, mechanical grilles and louvers, lighting fixture trim, and other items that have been removed to protect from contact with coatings.
- C. Reconnect equipment adjacent to surfaces indicated to receive coatings.
- D. Relocate to original position equipment and fixtures that have been moved to allow application of coatings.
- E. Remove protective materials.

3.7 PROTECTION

- A. Protect completed coating applications from damage by subsequent construction activities.
- B. Repair to Owner's acceptance coatings damaged by subsequent construction activities. Where repairs cannot be made to Owner's acceptance, re-apply finish coating to nearest adjacent change of surface plane, in both horizontal and vertical directions.

SPECIFICATIONS

Argyle Apartments

Window & Patio Door Replacement

3.8 PAINT SCHEDULE

- A. Finish surfaces in accordance with Color Schedule to be approved by Owner.
- B. Provide paint finishes of even, uniform color, free from cloudy or mottled appearance. Properly correct non-complying work to satisfaction of Owner's representative and representative of the Sherwin-Williams Company.
- C. Some colors, especially accent colors, may require multiple finish coats for adequate coverage and opacity.
- D. The specified number of primer and finish coats is minimum acceptable. If full coverage and opacity is not obtained with specified number of coats, apply additional coats as necessary to produce required finish.

3.9 EXTERIOR PAINT SCHEDULE

A. Caulks and Sealants

- 1. PVC, Plastic, Brick, Stone, Masonry, Marble, Stucco, Cementitious Siding, Vinyl Siding, Wood:
 - a. Exterior Acrylic Latex: SHER-MAX ULTRA Urethanized Elastomeric Sealant
- 2. Concrete: Vertical Applications
 - a. Exterior Polyurethane:
 - b. Sherwin-Williams Loxon S1 Sealant
 - c. Alternate Acrylic Latex: SHER-MAX ULTRA Urethanized Elastomeric Sealant
- 3. Concrete: Horizontal Applications
 - a. Exterior Polyurethane: Sherwin-Williams: Loxon SL1 Sealant
- 4. Gaps: Window & Door Frames
 - a. Interior/Exterior Insulating Foam: Sherwin-Williams STOP GAP! Minimal Expanding Insulating Foam
- 5. Gaps: Large Areas
 - a. Interior/Exterior Insulating Foam: Sherwin-Williams STOP GAP! Triple Expanding Insulating Foam
- 6. Glass: Glazing
 - a. Exterior Latex: Sherwin-Williams White Lightning Window & Door Siliconized Acrylic Latex Glazing Compound Alternate: Sherwin Williams C-66 Glazing Compound
- 7. Glass: Non-Structural Sealing
 - a. Exterior: Sherwin-Williams White Lightning Silicone Ultra

SPECIFICATIONS

Argyle Apartments

Window & Patio Door Replacement

8. Metal: Ferrous and Non-Ferrous
 - a. Exterior Polyurethane: Sherwin-Williams Loxon SL1 Sealant
- B. Paint and Coatings Systems
 1. Stucco Masonry Surfaces (Crack Repair)
 - a. Crack Repair: Identify all cracks in the existing substrates and repair per manufacturer's recommendation.
 - 1) For hairline cracks 1/16 inch or less wide — seal with Sherwin-Williams Concrete and Masonry Elastomeric Patching Compound (smooth or textured).
 - 2) For cracks 1/16-3/5 inch, route the crack open to a uniform size by mechanical methods. Clean out crack with water and allow to completely dry. Seal with Sherwin-Williams Concrete and Masonry Elastomeric Patching Compound (smooth or textured).
 - 3) For cracks deeper than 1/2 inch or wider than 1/4inch, backer rods should be used to fill the gap and to eliminate three-point adhesions. See data sheet for additional information.
 - b. Fiber Cement Siding/Trim: Unfinished or Pre-Primed
 - 1) Prime Coat (existing siding): Loxon Conditioner (LX03 Series) (applied 200-200 sqf per gallon)
 - 2) Prime Coat (new siding): Loxon Concrete & Masonry Primer (LX02 Series) at 5.3-8 mils WFT; 2.1-3.2 mils DFT.
 - 3) Two Finish Coats: Duration Exterior Acrylic Satin Finish (K33W250 Series) at 5.3-6.4 mils WFT; 2.1-2.5 mils DFT each coat.
 - c. Aluminum Gutters, Downspouts, Flashing, Vents, Panels, Utility Boxes, Conduit and other Incidentals

Note: Gutters should be cleaned inside and out and working prior to painting.

- 1) Spot / Prime Coat: Pro Industrial Pro-Cryl (B66-1310 Series) at 5-10 mils WFT; 2-4 mils DFT.
 - 2) Two Finish Coats: Duration Exterior Acrylic Satin Finish (K33W250 Series) at 5.3-6.4 mils WFT; 2.1-2.5 mils DFT each coat.
- d. Wood Trim and Awning Frames
 - 1) Prime Coat: Prime new or bare areas Exterior Latex Wood Primer (B42W8041) at 4 mils WFT; 1.2 mils DFT.

Note: For wood that is considered a tannin bleeding wood, use Exterior Oil Based Primer (Y24W8020).

- 2) Two Finish Coats: Duration Exterior Acrylic Satin Finish (K33W250 Series) at 5.3-6.4 mils WFT; 2.1-2.5 mils DFT each coat.

Note: Rough sawn wood surfaces must be back-rolled to ensure proper adhesion and a smooth final appearance.

SPECIFICATIONS

Argyle Apartments

Window & Patio Door Replacement

- e. Fiber Cement Siding/Trim: Unfinished or Pre-Primed
 - 1) Prime Coat (existing concrete): Loxon Conditioner (LX03 Series) applied at approx. 200-300 sq ft per gallon. Prime Coat (new concrete): Loxon Concrete & Masonry Primer (LX02 Series) at 5.3-8 mils WFT; 2.1-3.2 mils DFT.
 - 2) Two Finish Coats: Duration Exterior Acrylic Satin Finish (K33W250 Series) at 5.3-6.4 mils WFT; 2.1-2.5 mils DFT each coat.

- f. Ferrous Metal - Posts, Railings, Entry / Service Doors Jambs, Staircase Supports
 - 1) Spot / Prime Coat: Pro Industrial Pro-Cryl Universal Metal Primer (B66-1310 Series) at 5-10 mils WFT; 2-4 mils DFT. Kem Kromik Universal Metal Primer (B50-XZ Series) at 6-8 mils WFT; 3.3-4.4 mils DFT.
 - 2) Finish Coat: Pro Industrial Water-Based Alkyd Urethane Semi-Gloss (B53-1050 Series) at 4-5 mils WFT; 1.4-1.7 mils DFT each coat.

- g. Non-Ferrous Metal – Garage Doors, Galvanized Metal, Roof Flashing
 - 1) Spot Prime Coat: Pro Industrial Pro-Cryl Universal Metal Primer (B66-1310 Series) at 5-10 mils WFT; 2-4 mils DFT.
 - 2) B. Finish Coat: Pro Industrial Water-Based Alkyd Urethane Semi-Gloss (B53-1050 Series) at 4-5 mils WFT; 1.4-1.7 mils DFT each coat

- h. Ferrous Metal – Awnings, Awning Framing, Trellis
 - 1) Spot / Prime Coat: Kem Kromik Universal Metal Primer (B50-XZ Series) at 6-8 mils WFT; 3.3-4.4 mils DFT.
 - 2) Finish Coat: Pro Industrial Urethane Alkyd Enamel Semi-Gloss (B54W00150 Series) at 3.5-7.0 mils WFT; 2.0-4.0 mils DFT each coat.

- i. Non-Ferrous Metal – Roofing
 - 1) Full Prime Coat: Pro Industrial Pro-Cryl Universal Metal Primer (B66-1310 Series) at 5-10 mils WFT; 2-4 mils DFT.
 - 2) Finish Coat: Pro Industrial Sher-Cryl HPA Gloss (B66-350 Series) at 6-10 mils WFT; 2.0-3.3 mils DFT each coat.

3.10 COLORS

A. Color Scheme

- 1. Color scheme attached.

END OF SECTION 09911



ARGYLE APARTMENTS

2517 South 316th Lane, Federal Way, WA 98003

WINDOWS

PLAN SHEET - 1.0

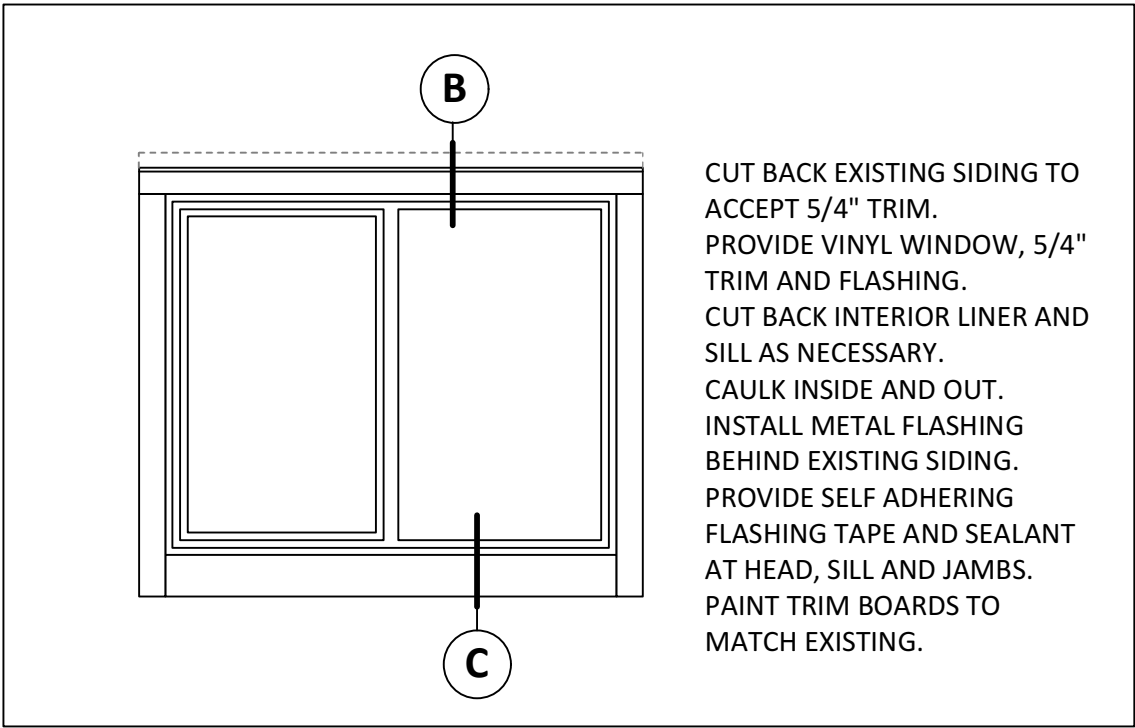

A TYPICAL WINDOW INSTALLATION

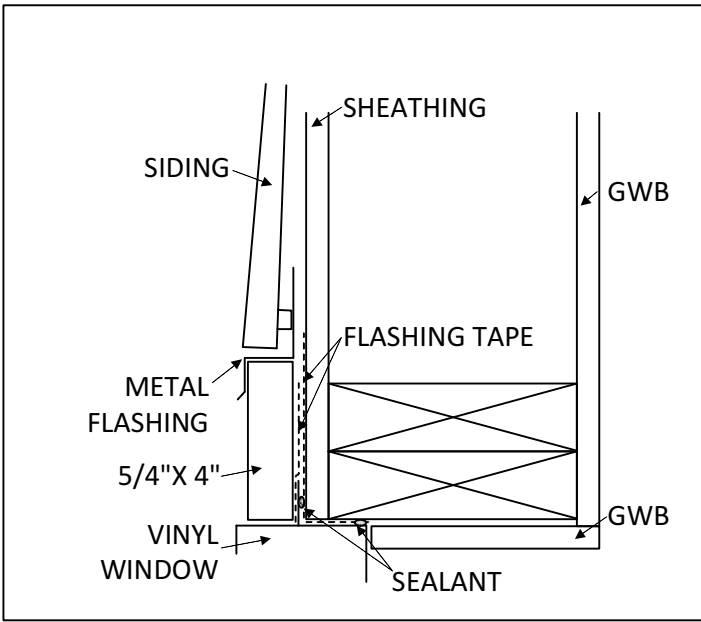

B TYPICAL HEAD SECTION

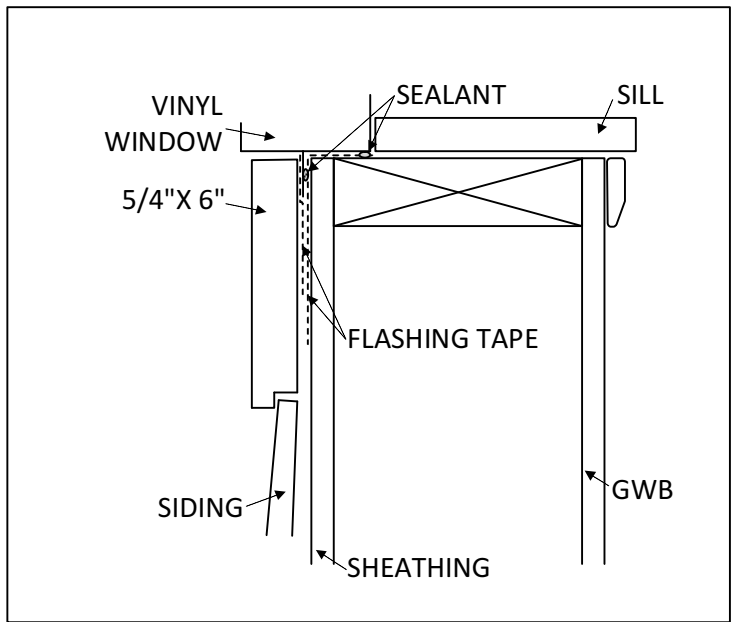

C TYPICAL SILL SECTION

WINDOW DETAIL	Drawn: HUGH WATKINSON	Date: Revisions:	ARGYLE APARTMENTS 2517 South 316th Lane, Federal Way, WA 98003 WINDOW REPLACEMENT
	_____ _____ _____		

INSTRUCTIONS TO BIDDERS

1.0 BIDDER RESPONSIBILITY CRITERIA

- A. It is the intent of Owner to award a contract to a responsible bidder submitting the lowest responsive bid. Before award, the bidder must meet the following bidder responsibility criteria to be considered a responsible bidder. The bidder may be required by the Owner to submit documentation demonstrating compliance with the criteria. The bidder must:
1. Have a current certificate of registration as a contractor in compliance with chapter 18.27 RCW, which must have been in effect at the time of bid submittal;
 2. Have a current Washington Unified Business Identifier (UBI) number;
 3. If applicable, have industrial insurance coverage for the bidder's employees working in Washington as required in Title 51 RCW; an employment security department number as required in Title 50 RCW; and a state excise tax registration number as required in Title 82 RCW;
 4. Not be disqualified from bidding on any public works contract under RCW 39.06.010 or 39.12.065(3);
 5. Have received training on the requirements related to public works and prevailing wage under chapter 39.04.350 RCW and chapter 39.12 RCW or be listed as exempt by the department of labor and industries on its website; and
 6. Within the three-year period immediately preceding the date of the bid solicitation, not have been determined by a final and binding citation and notice of assessment issued by the department of labor and industries or through a civil judgment entered by a court of limited or general jurisdiction to have willfully violated, as defined in RCW 49.48.082, any provision of chapter 49.46, 49.48, or 49.52 RCW;
 7. Before award of a public works contract, a bidder shall submit to the contracting agency a signed statement in accordance with RCW 9A.72.085 verifying under penalty of perjury that the bidder is in compliance with the responsible bidder criteria requirement of subsection A, 6 of this section.

1.1 SUBCONTRACTOR RESPONSIBILITY

- A. The Contractor shall include the language of this section in each of its first tier subcontracts, and shall require each of its subcontractors to include the same language of this section in each of their subcontracts, adjusting only as necessary the terms used for the contracting parties. Upon request of the Owner, the Contractor shall promptly provide documentation to the Owner demonstrating that the subcontractor meets the subcontractor responsibility criteria below. The requirements of this section apply to all subcontractors regardless of tier.
- B. At the time of subcontract execution, the Contractor shall verify that each of its first tier subcontractors meets the following bidder responsibility criteria:
1. Have a current certificate of registration in compliance with chapter 18.27 RCW, which must have been in effect at the time of subcontract bid submittal;
 2. Have a current Washington Unified Business Identifier (UBI) number;
 3. If applicable, have:
 - a. Have Industrial Insurance (workers' compensation) coverage for the subcontractor's employees working in Washington, as required in Title 51 RCW;
 - b. A Washington Employment Security Department number, as required in Title 50 RCW;

INSTRUCTIONS TO BIDDERS

- c. A Washington Department of Revenue state excise tax registration number, as required in Title 82 RCW;
 - d. An electrical contractor license, if required by Chapter 19.28 RCW;
 - e. An elevator contractor license, if required by Chapter 70.87 RCW.
4. Not be disqualified from bidding on any public works contract under RCW 39.06.010 or 39.12.065 (3);
 5. Have received training on the requirements related to public works and prevailing wage under chapter 39.04.350 RCW and chapter 39.12 RCW or be listed as exempt by the department of labor and industries on its website; and
 6. Within the three-year period immediately preceding the date of the bid solicitation, not have been determined by a final and binding citation and notice of assessment issued by the department of labor and industries or through a civil judgment entered by a court of limited or general jurisdiction to have willfully violated, as defined in RCW 49.48.082, any provision of chapter 49.46, 49.48, or 49.52 RCW.

1.2 SUPPLEMENTAL BIDDER RESPONSIBILITY CRITERIA

- A. RCW 39.04.350(2) specifically authorizes municipalities to adopt relevant supplement criteria for determining bidder responsibility applicable to a particular project which the bidder must meet.
- B. For the work in this project a responsible/qualified Bidder must meet the following standards:
 1. Have a current certificate of registration as a contractor, in compliance with chapter 18.27 RCW, for the last three years under the same business name;
 2. Have a good record of past performance that includes, but is not limited to, high quality work, ability to complete projects on time, contractor's integrity, compliance with public policy, financial, contractual and tax obligations, as well as Federal and State rules and regulations in performing construction contracts.
 3. Have a current Experience Modification Rate (EMR) of 1.0 or less, or an average EMR rate of 1.0 or less over the last three years. The requirement may, at the Owner's sole discretion, be waived on review of a written explanation that includes details of accidents, L&I records, a Loss Ratio Report for the last five years, costs, dates of events, and changes that have been made by the contractor to reduce accidents. A current company Safety Plan shall also be reviewed.
 4. Bidder shall provide evidence of previous successful completion of window & door installation projects of similar scope and complexity. Poor performance, lack of response, or failure to complete projects successfully within the contract time may be grounds for the rejection of bidder.
- C. Subcontractors shall have had three years minimum experience licensed in Washington State in the specific specialty contracting business.

1.3 PREPARATION OF BIDS – CONSTRUCTION

- A. Bids must be submitted on the Bid Form furnished by the Owner.
- B. All fields and questions on required forms must be fully answered and complete. Failure to do so may result in the bid being declared non-responsive.

INSTRUCTIONS TO BIDDERS

- C. Bidders shall acknowledge receipt of all addenda to this solicitation by inserting the addenda numbers in the space provided on the Bid Form. Failure to do so may result in the bid being declared non-responsive.
 - 1. Bidder is responsible for checking KCHA's website for addenda prior to submitting bid.
- D. In order for a bid to be considered responsive, bidders must submit the following signed documents with their bid package:
 - 1. Bid Form
 - 2. Bidder's Information Form
- E. The Bidder agrees to hold the base bid prices for sixty (60) days from date of bid opening.

1.4 AMENDMENTS TO INVITATION TO BID

- A. If this solicitation is amended, then all terms and conditions which are not modified remain unchanged.
- B. Bidders shall acknowledge receipt of all addenda to this solicitation by inserting the addenda numbers in the space provided on the Bid Form. Failure to do so may result in the bid being declared non-responsive.
 - 1. Bidder is responsible for checking KCHA's website for addenda prior to the bid due date.
 - 2. Addenda will not be issued later than three (3) calendar days before the deadline for receipt of Bids except Addendum withdrawing the request for Bids or extending the deadline for receipt of Bids.

1.5 PRE-BID MEETING

- A. All potential bidders are strongly encouraged to attend. Oral statements may not be relied upon and will not be binding or legally effective.

1.6 EXAMINATION OF PLANS, SPECIFICATIONS, AND SITE

- A. Before submitting a bid, the Bidder shall carefully examine each component of the Contract Documents prepared for the Work and any other available supporting data so as to be thoroughly familiar with all the requirements.
- B. The Bidder shall obtain copies of all agencies and associations guidelines and standards cited in the Contract Documents and necessary to perform the Work, including full size reproductions of material provided by Owner, at their own expense.
- C. The Bidder shall make a thorough and reasonable examination of the project site, facility and conditions under which the Work is to be performed, including but not limited to: Building access; resident occupancy; fire lanes; landscaping; obstacles and character of materials which may be encountered; traffic conditions; public and private utilities; the availability and cost of labor; and available facilities for transportation, handling, and storage of materials and equipment.

INSTRUCTIONS TO BIDDERS

1.7 EXPLANATION TO PROSPECTIVE BIDDERS

- A. Any prospective bidder desiring an explanation or interpretation of the solicitation, drawings, specifications, etc., must submit a request in writing to the Owner seven (7) calendar days before the bid due date. Oral explanations or instructions given before the award of a contract will not be binding. Questions shall be submitted to:

Michelle Jackson
King County Housing Authority
600 Andover Park W
Seattle, WA 98188
Email: MichelleJ@kcha.org

1.8 PREVAILING WAGES

- A. Contractor shall pay no less than the Washington State Department of Labor and Industries (L&I) prevailing rate of wages to all workers, laborers, or mechanics employed in the performance of any part of the Work in accordance with RCW 39.12 and the rules and regulations of L&I. The schedule of prevailing wage rates for the locality or localities of the Work is determined by the Industrial Statistician of L&I. It is the Contractor's responsibility to verify the applicable prevailing wage rate.
1. L&I prevailing wage rates may be found at <https://lni.wa.gov/licensing-permits/public-works-projects/prevailing-wage-rates/>
 2. The Owner has determined that the work meets the definition of residential construction.
 3. The prevailing wage rates publication date is determined by the bid due date.
 4. The work is to be performed in King County.
 5. A copy of the prevailing wage rates is available at KCHA.
 6. A copy of the prevailing wage rates may be mailed on request.

1.9 TAXES

- A. All taxes imposed by law shall be included in the bid amount. The Contractor shall pay the WSST to the Department of Revenue and shall furnish proof of payment to the Owner if requested.
- B. The retail sales tax does not apply to the gross contract price as indicated in WAC 458-20-17001.
- C. Prime and subcontractors are required to pay retail sales tax upon all purchases of materials, including prefabricated and precast items, equipment, leases or rentals of tools, consumables, and other tangible personal property which is installed, applied, attached, or otherwise incorporated in their work.

1.10 ASSURANCE OF COMPLETION

- A. Payment and performance bonds for 100% of the Contract Sum, including all Change Orders and taxes imposed by law, shall be furnished for the Work, and shall be in a form acceptable to the Owner.

INSTRUCTIONS TO BIDDERS

1. On contracts of one hundred fifty thousand dollars (\$150,000.00) or less, the requirement for a Performance and Payment Bond may, at Contractors option, be waived in lieu of an additional 5% (total 10%) retainage.

1.11 BID ERROR

- A. In the event Bidder discovers an error in its bid, the Bidder may, under certain conditions and if before the date and time that bids are due, modify, their bid, as detailed below:

1. Prior to Date and Time Bids are Due:

- a. A Bidder may withdraw its bid at any time prior to the date and time bids are due upon written request.
- b. After withdrawing an original submitted bid, a Bidder may modify and resubmit its bid at any time prior to the date and time bids are due.

2. After the Date and Time Bids are Due:

- a. A bidder who submits an erroneous low bid may withdraw the bid. The bid withdrawal is permissible if there was an obvious error in the low bid, and the mistake is readily apparent from the bid itself.
- b. Notification: Provide to the Owner, within 24 hours of bid opening, written notification of the bidder's intent to withdraw the bid due to error.
- c. Documentation: Provide to the Owner within 48 hours of bid opening, documentation sufficient in content to justify bid withdrawal to the satisfaction of the Owner. Include description and evidence of the error.
- d. Approval: the Owner will approve or reject the request for withdrawal in writing.
- e. Any low bidder who withdraws its bid is prohibited from bidding on the same project if it is subsequently re-solicited.

1.12 ADDITIVE OR DEDUCTIVE BID ITEMS

- A. The low bid, for purposes of award, shall be the lowest responsive bid from a qualified responsible bidder offering the low aggregate amount for the base bid, plus additive or deductive bid alternates selected by the Owner.

1.13 BID EVALUATION

- A. Responsive Bids: A bid will be considered responsive if it meets the conditions of the solicitation, in addition to but not limited to the following requirements:

1. Bid is received not later than the time and date specified.
2. Bid is submitted in the proper format on the form(s) provided.
3. Bid includes the complete scope of work as defined in bid package.
4. Bid does not include any exclusions or qualifications.
5. Bid includes Unit and Lump Sum Costs as listed in Proposal Form.
6. Forms are complete.

- B. After bid opening, bids will be checked for correctness of bid item price extensions and the total bid price. A discrepancy between a bid item price and the extended amount of any bid item shall be resolved by accepting the bid item price as correct.

INSTRUCTIONS TO BIDDERS

- C. Responsible Bidders: the Owner will award contracts only to responsible bidders who demonstrate the ability to successfully perform under the terms and conditions as set forth in the Contract Documents and have successfully completed projects similar in scope and complexity.
 - 1. Bidders must demonstrate relevant experience on similar types of projects and submit detailed information as required on the Bidder Information Form.
- D. The Owner reserves the right to contact references and investigate past performance and qualifications of the Bidder, subcontractor, and project team members, including contacting third parties and/or the references provided by the Bidder.
 - 1. The Owner may contact references for other projects including those the Bidder did not identify and/or provided references.
 - 2. References may be asked to rate the performance of and describe their experience with project team members and subcontractors. Bidder Information may be solicited and evaluated on the following subjects: type and features of work; overall quality of project performance and quality of work; experience and technical knowledge and competence of the Bidder and Project Team Members; ability, capacity and skill to perform the Work; ability to manage submittals, requests for information, prevailing wage filings, and other paperwork; compliance with laws, ordinances, and contract provisions; and other information as deemed necessary.
 - 3. Poor reference(s) may be justification to determine a Bidder is not responsible.
- E. At the Owner's request, provide any additional explanation or information, which would assist in evaluating the qualifications of the Bidder, subcontractors, project team members, and bid price.
- F. The Owner will verify information submitted and if the lowest bidder is determined to be “not responsible,” the Owner will issue, in writing, the specific reasons for this determination. The bidder may appeal this decision. The appeal must be in writing and shall be delivered to the Owner within two business days. The appeal may include additional information that was not included in the original bid documents. KCHA will make a final determination after the receipt of the appeal. The final determination may not be appealed.

1.14 CONTRACT AWARD

- A. Bonding and Insurance: Contract award will be contingent on ability to secure payment/performance bonding, and Contractor’s ability to meet the Owner insurance requirements as detailed in the Bid Documents.
- B. Bonding, insurance certificates and endorsements, and an approved Statement of Intent to Pay Prevailing Wages shall be submitted to the Owner within 14 days of award. A Notice to Proceed shall be issued immediately after receipt.
- C. Right to Reject Bids/Waiver: The Owner reserves the right to reject any or all bids or to waive any informalities or irregularities in the bidding.
- D. Retainage Funds: The Owner will not pay interest to the Contractor for accounts where retainage funds are maintained by the Owner. As part of the procurement by which the Contractor was selected for this work, the Contractor agrees to waive any other options and has made allowances for this waiver.

GENERAL CONDITIONS

PART 1 - GENERAL PROVISIONS

1.1 DEFINITIONS

- A. "Authority Having Jurisdiction (AHJ)": A federal, state, local, or other regional department, or an individual such as a fire official, labor department, health department, building official, or other individual having statutory authority.
- B. "Contract Documents" means the Instructions to Bidders, Specifications, Plans, General Conditions, Prevailing Wage Rates, Bid Form, Contract Form, other Special Forms, Drawings and Specifications, and all Addenda and modifications thereof.
- C. "Contract Sum" is the total amount payable by Owner to Contractor for performance of the Work in accordance with the Contract Documents.
- D. "Contract Time" is the number of consecutive Days allotted in the Contract Documents for achieving completion of the Work.
- E. "Contracting Officer" means the person delegated the authority by King County Housing Authority to enter into, and/or terminate this Contract. The term includes any successor Contracting Officer and any duly authorized representative of the Contracting Officer.
- F. "Contractor" means the person or other entity entering into the Contract with King County Housing Authority to perform all of the services or work required under the Contract.
- G. "Day" means calendar day, unless otherwise specified.
- H. "Final Acceptance" means the acceptance by Owner that the Contractor has completed the requirements of the Contract Documents.
- I. "Force Majeure" means those acts entitling Contractor to request an equitable adjustment in the Contract Time, including, but not limited to, unusually severe weather conditions which could not have been reasonably anticipated.
- J. "Furnish": Supply and deliver to Project site, ready for unloading, unpacking, assembly, installation, and similar operations.
- K. "Install": Operations at Project site including unloading, temporarily storing, unpacking, assembling, erecting, placing, anchoring, applying, working to dimension, finishing, curing, protecting, cleaning, and similar operations.
- L. "Liquidated Damages" means the amount prescribed in the Contract Documents to be deducted from any payments due or to become due Contractor, for each day's delay in completion of the Work beyond the time allowed in the Contract Documents as stated in the Notice to Proceed, plus any extensions of such time.
- M. "Manager" means the person who is an authorized agent of the King County Housing Authority to administer the Contract.
- N. "Notice to Proceed" means a notice from Owner to Contractor that defines the date on which the Contract Time begins to run.
- O. "Owner" means the King County Housing Authority or its authorized representative with the authority to enter into, administer, and/or terminate the Work in accordance with the Contract Documents and make related determinations and findings.
- P. "Property Manager" means the property management company, its officers and employees.
- Q. "Provide": Furnish and install, complete and ready for the intended use.

GENERAL CONDITIONS

- R. "Subcontract" means any contract, purchase order, or other purchase agreement, including modifications and change orders to the foregoing, entered into by a Subcontractor to furnish supplies, materials, equipment, and services for the performance of the prime Contract or a subcontract.
- S. "Subcontractor" means any supplier, vendor, or firm that furnishes supplies, materials, equipment, or services to or for the Contractor or another Subcontractor.
- T. "Work" means the construction and services required by the Contract Documents, and includes, but is not limited to, labor, materials, supplies, equipment, services, permits, and the manufacture and fabrication of components, performed, furnished, or provided in accordance with the Contract Documents.

1.2 EXECUTION AND INTENT

- A. The intent of the Specifications and Drawings is to describe a complete Project to be constructed in accordance with the Contract Documents. Contractor shall furnish all labor, materials, equipment, tools, transportation, permits, and supplies, and perform the Work required in accordance with the Contract Documents.
- B. All work is to be executed in accordance with the Building Codes, as adopted by the Authority Having Jurisdiction, and other applicable codes and generally accepted industry standards. All products and materials are to be new and handled and applied in accordance with the manufacturer's recommendations.
- C. Contractor makes the following representations to Owner:
 - 1. The Contract Sum is reasonable compensation for the Work and the Contract Time is adequate for the performance of the Work, as represented by the Contract Documents;
 - 2. Contractor has carefully reviewed the Contract Documents, had an opportunity to visit and examine the Project site, has become familiar with the local conditions in which the Work is to be performed, and has satisfied itself as to the nature, location, character, quality and quantity of the Work, the labor, materials, equipment, goods, supplies, work, permits, services and other items to be furnished and all other requirements of the Contract Documents, as well as the surface and subsurface conditions and other matters that may be encountered at the Project site or affect performance of the Work or the cost or difficulty thereof.
- D. The Contract Documents are complementary. What is required by one part of the Contract Documents shall be binding as if required by all. Anything mentioned in the Specifications and not shown on the Drawings, or shown on the Drawings and not mentioned in the Specifications, shall be of like effect as if shown or mentioned in both.

PART 2 - INSURANCE AND BONDS

2.1 INSURANCE REQUIREMENTS FOR BUILDING TRADES CONTRACTORS

- A. Contractor shall procure and maintain for the duration of the contract insurance against claims for injuries to persons or damages to property that may arise from or in connection with the performance of the work hereunder by the Contractor, his agents, representatives, employees or Subcontractors.

2.2 MINIMUM SCOPE OF INSURANCE

- A. Contractors shall maintain coverages no less than:
 - 1. Insurance Services Office Commercial General Liability coverage including Products/Completed Operations.
 - 2. Insurance Services Office covering Automobile Liability, code 1 (any auto).
 - 3. Workers' Compensation insurance as required by State law and Employer's Liability Insurance.

GENERAL CONDITIONS

2.3 MINIMUM LIMITS OF INSURANCE

A. Contractor shall maintain limits no less than:

1. General Liability: \$1,000,000 per occurrence for bodily injury, personal injury and property damage. If Commercial General Liability Insurance or other form with a general aggregate limit is used, either the general aggregate limit shall apply separately to this project/location or the general aggregate limit of \$2,000,000.
2. Automobile Liability: \$1,000,000 per accident for bodily injury and property damage.
Employer's Liability: \$1,000,000 per accident for bodily injury/sickness or disease.

2.4 DEDUCTIBLES AND SELF INSURED RETENTION

- ### A.
- Any deductibles or self-insured retentions must be declared to and approved by the Owner. At the option of the Owner, either: the insurer shall reduce or eliminate such deductibles or self-insured retentions as respects the Owner, its officers, officials, employees and volunteers; or the Contractor shall provide a financial guarantee satisfactory to the Owner guaranteeing payment of losses and related investigations, claim administration and defense expenses. **NOTE: If this contract deals with hazardous materials or activities (i.e. lead based paint, asbestos, armed security guards) additional provisions covering those exposures must be included in order to protect the Owner's interests.**

2.5 OTHER INSURANCE PROVISIONS

A. The policies are to contain, or be endorsed to contain, the following provisions:

1. The Owner, the Property Manager, its officers, officials, employees, partners, agents and volunteers are to be covered as additional insureds under a "completed operations" type of additional insured endorsement with respect to general liability arising out of work or operations performed by or on behalf of the Contractor including materials, parts or equipment furnished in connection with such work or operations. The endorsement(s) effectuating the foregoing additional insured coverage shall be ISO form CG 20 10 11 85, or CG 20 10 10 01 issued concurrently with CG 20 37 10 01, or their equivalent as long as it provides additional insured coverage, without limitation, for completed operations; (ii) automobile liability arising out of vehicles owned, leased, hired, or borrowed by or on behalf of the Contractor; (iii) any insurance written on a claims made basis, shall have a retroactive date that coincides with, or precede, the commencement of any work under this contract. Evidence of such coverage shall be maintained for a minimum of six (6) years beyond the expiration of the project.
2. King County will not accept Certificates of Insurance Alone. Improperly Completed Endorsements will be returned to your insured for correction by an authorized representative of the insurance company.
3. For any claims related to this project, the Contractor's insurance coverage shall be primary insurance as respects the Owner, its officers, officials, agents, partners, employees, and volunteers. Any insurance or self-insurance maintained or expired by the Owner, its officers, officials, agents, partners, employees, volunteers, or shall be excess of the Contractor's insurance and shall not contribute with it. King County Housing Authority's Insurance is Non-Contributory in Claims Settlement Funding.
4. The "General description of agreement(s) and/or activity(s) insured" shall include reference to the activity and/or to either specific King County Housing Authority's; project of site name, contract number, lease number, permit number or construction approval number.
5. Each insurance policy required by this clause shall be endorsed to state that coverage shall not be canceled or materially changed, except after thirty (30) days' [ten (10) days for non-payment of premium] prior written notice by certified mail, return receipt requested, has been given to the Owner.
6. Maintenance of the proper insurance for the duration of the contract is a material element of the contract. Material changes in the required coverage or cancellation of the coverage shall constitute a material breach of the contract.

2.6 ACCEPTABILITY OF INSURERS

- ### A.
- Insurance is to be placed with insurers with a current A.M. Best's rating of no less than A-:VII. The name of the Insurance Company underwriting the coverage and its address shall be noted on the endorsement form. Contractors must provide written verification of their insurer's rating.

GENERAL CONDITIONS

2.7 VERIFICATION OF COVERAGE

- A. Contractor shall furnish the Owner with original certificates and amendatory endorsements effecting coverage required by this clause. All certificates and endorsements are to be received and approved by the Owner before work commences in sufficient time to permit contractor to remedy any deficiencies. The Owner reserves the right to require complete, certified copies of all required insurance policies or pertinent parts thereof, including endorsements affecting the coverage required by these specifications at any time.

2.8 SUBCONTRACTORS

- A. Subcontractors shall include the Contractor as additional insured under their policies. All coverage's for subcontractors shall be subject to all of the requirements stated herein. Contractor shall be responsible for the adequacy of required coverages for subcontractors, and compile related certificates of insurance and endorsements evidencing subcontractors' compliance.

2.9 PAYMENT AND PERFORMANCE BONDS

- A. Payment and performance bonds for 100% of the Contract Award Amount shall be furnished for the Work, using the Payment Bond and Performance Bond form AIA – form A312. Change order increases of cumulative 15% increments require revisions to the bond to match the new Contract Sum.
- B. On contracts of one hundred fifty thousand dollars or less, at the option of the contractor as defined in RCW 39.10.210, the Owner may, in lieu of the bond, retain ten percent of the contract amount for a period of forty-five days after date of final acceptance, or until receipt of all necessary releases from the department of revenue, the employment security department, and the department of labor and industries and settlement of any liens filed under chapter 60.28 RCW, whichever is later.

PART 3 - PERFORMANCE

3.1 CONTRACTOR CONTROL AND SUPERVISION

- A. Contractor shall be solely responsible for, and have control over construction means, methods, techniques, sequences, and procedures and for coordinating all portions of the Work, and shall be responsible to Owner for acts and omissions of Contractor, Subcontractors, and their employees and agents.
- B. Contractor shall enforce strict discipline and good order among Contractor's employees and other persons performing the Work. Contractor shall not permit employment of persons not skilled in tasks assigned to them. Owner may, by Notice, request Contractor to remove from the Work or Project site any employee Owner reasonably deems incompetent, careless, or otherwise objectionable.
- C. The Contractor shall perform on the site, and with its own organization, work equivalent to at least 12% of the total amount of work to be performed under the contract.
- D. Work Hours: The Contractor's allowable hours of operation shall be limited to those hours between 8:00 A.M. and 6:00 P.M. Monday to Friday excluding public holidays.

3.2 PERMITS, FEES, AND NOTICES

- A. Unless otherwise provided in the Contract Documents, Contractor shall pay for and obtain all permits, licenses, and coordinate inspections necessary for proper execution and completion of the Work. Prior to final payment, the approved, signed permits shall be delivered to Owner.

3.3 PREVAILING WAGES

- A. Statutes of the State of Washington RCW 39.12 as amended shall apply to this contract. Requirements, in brief, are stated below:

GENERAL CONDITIONS

1. There shall be paid each laborer or mechanic of the Contractor or sub-Contractor engaged in work on the project under this contract in the trade or occupation listed in the schedule of Wage Rates, as determined by the Department of Labor and Industries, not less than the hourly wage rate listed therein, regardless of any contractual relationship which may be alleged to exist between the Contractor and any sub-contractor and such laborers and mechanics.
2. The "prevailing rate or wage" contained in the wage determination include health and welfare fund contributions and other fringe benefits collectively bargained for by the various management and labor organizations. Prevailing wages shall be paid based on the most recent semi-annual list as required by the Department of Labor and Industries (L&I).
3. In case any dispute arises as to what are the prevailing rates for wages of work of a similar nature, and such disputes cannot be resolved by the parties involved, including labor and management representatives, the matter shall be referred for arbitration to the Director of the Department of Labor and Industries of the State of Washington, and the Director's decision shall be final and conclusive and binding on all parties involved in the dispute.

B. Before commencing the Work, Contractor shall file a statement of "Intent to Pay Prevailing Wages."

C. After completion of the Work, Contractor shall file an "Affidavit of Wages Paid."

3.4 EQUAL EMPLOYMENT OPPORTUNITY

A. During performance of the Work:

1. Contractor shall not discriminate against any employee or applicant for employment because of race, creed, color, national origin, sex, age, marital status, the presence of any physical, sensory, or mental disability, sexual orientation, Vietnam-era veteran status, disabled veteran status or political affiliation, nor commit any unfair practices as defined in RCW 49.60.
2. The Contractor shall take affirmative action to ensure that applicants are employed, and that employees are treated during employment without regard to their race, color, religion, sex, national origin, of any physical, sensory, or mental disability, sexual orientation, Vietnam-era veteran status, disabled veteran status, or political affiliation.
3. The Contractor shall give all notices and comply with all applicable laws, ordinances, rules, regulations and orders in regard to Equal Employment Opportunity including but not limited to Executive Order 11246, as amended, Section 503 of the Rehabilitation Act of 1973, as amended, and the rules, regulations, and orders of the Secretary of Labor. The Contractor shall include the terms of this Clause in every subcontract so that such term shall be binding on each Subcontractor.
4. Non-Discrimination R.C.W. 49.60: These special requirements establish minimum requirements for affirmative action and are intended to define and implement the basic discrimination provisions of these specifications. Failure to comply with these requirements may constitute grounds for application of contract default.

3.5 SAFETY PRECAUTIONS

A. In performing this contract, the Contractor shall provide for protecting the lives and health of employees and other persons; preventing damage to property, materials, supplies, and equipment; and avoid work interruptions. For these purposes, the Contractor shall:

1. Follow Washington Industrial Safety and Health Act (WISHA) regional directives and provide a site-specific safety program that will require an accident prevention and hazard analysis plan for the contractor and each subcontractor on the work site. The Contractor shall submit a site-specific safety plan to the Owner's representative prior to the initial scheduled construction meeting.
2. Provide adequate safety devices and measures including, but not limited to, the appropriate safety literature, notice, training, permits, placement and use of barricades, signs, signal lights, ladders, scaffolding, staging, runways, hoist, construction elevators, shoring, temporary lighting, grounded outlets, wiring, hazardous materials, vehicles, construction processes, and equipment required by Chapter 19.27 RCW, State Building Code (Uniform Building, Electrical, Mechanical, Fire, and Plumbing Codes); Chapter 212-12 WAC, Fire Marshal Standards, Chapter 49.17 RCW, WISHA; Chapter 296-155 WAC, Safety Standards for Construction Work; Chapter 296-65 WAC; WISHA Asbestos Standard; WAC 296-62-071, Respirator Standard; WAC 296-62, General Occupation Health Standards, WAC 296-24, General Safety and Health Standards, WAC 296-24, General Safety and Health Standards, Chapter 49.70 RCW, and Right to Know Act.

GENERAL CONDITIONS

3. Comply with the State Environmental Policy Act (SEPA), Clean Air Act, Shoreline Management Act, and other applicable federal, state, and local statutes and regulations dealing with the prevention of environmental pollution and the preservation of public natural resources.
 4. Post all permits, notices, and/or approvals in a conspicuous location at the construction site.
 5. Provide any additional measures that the Owner determines to be reasonable and necessary for ensuring a safe environment in areas open to the public. Nothing in this part shall be construed as imposing a duty upon the Owner to prescribe safety conditions relating to employees, public, or agents of the Contractors.
- B. Contractor to maintain safety records: Contractor shall maintain an accurate record of exposure data on all incidents relating to the Work resulting in death, traumatic injury, occupational disease, or damage to property, materials, supplies, or equipment. Contractor shall immediately report any such incident to Owner. Owner shall, at all times, have a right of access to all records of exposure.
- C. Contractor to provide HazMat training: Contractor shall provide all persons working on the Project site with information and training on hazardous chemicals in their work at the time of their initial assignment, and whenever a new hazard is introduced into their work area.
1. Information. At a minimum, Contractor shall inform persons working on the Project site of:
 - a. WAC: The requirements of chapter 296-62 WAC, General Occupational Health Standards;
 - b. Presence of hazardous chemicals: Any operations in their work area where hazardous chemicals are present; and
 - c. Hazard communications program: The location and availability of written hazard communication programs, including the required list(s) of hazardous chemicals and material safety data sheets required by chapter 296-62 WAC.
 2. Training. At a minimum, Contractor shall provide training for persons working on the Project site which includes:
 - a. Detecting hazardous chemicals: Methods and observations that may be used to detect the presence or release of a hazardous chemical in the work area (such as monitoring conducted by the employer, continuous monitoring devices, visual appearance or odor of hazardous chemicals when being released, etc.);
 - b. Hazards of chemicals: The physical and health hazards of the chemicals in the work area;
 - c. Protection from hazards: The measures such persons can take to protect themselves from these hazards, including specific procedures Contractor, or its Subcontractors, or others have implemented to protect those on the Project site from exposure to hazardous chemicals, such as appropriate work practices, emergency procedures, and personal protective equipment to be used; and
 - d. Hazard communications program: The details of the hazard communications program developed by Contractor, or its Subcontractors, including an explanation of the labeling system and the material safety data sheet, and how employees can obtain and use the appropriate hazard information.
- D. Hazardous, toxic or harmful substances: Contractor's responsibility for hazardous, toxic, or harmful substances shall include the following duties:
1. Illegal use of dangerous substances: Contractor shall not keep, use, dispose, transport, generate, or sell on or about the Project site, any substances now or hereafter designated as, or which are subject to regulation as, hazardous, toxic, dangerous, or harmful by any federal, state or local law, regulation, statute or ordinance (hereinafter collectively referred to as "hazardous substances"), in violation of any such law, regulation, statute, or ordinance, but in no case shall any such hazardous substance be stored on the Project site.
 2. Contractor notifications of spills, failures, inspections, and fines: Contractor shall promptly notify Owner of all spills or releases of any hazardous substances which are otherwise required to be reported to any regulatory agency and pay the cost of cleanup. Contractor shall promptly notify Owner of all failures to comply with any federal, state, or local law, regulation, or ordinance; all inspections of the Project site by any regulatory entity concerning the same; all regulatory orders or fines; and all responses or interim cleanup actions taken by or proposed to be taken by any government entity or private party on the Project site.

GENERAL CONDITIONS

- E. Public safety and traffic: All Work shall be performed with due regard for the safety of the public. Contractor shall perform the Work so as to cause a minimum of interruption of vehicular traffic or inconvenience to pedestrians. All arrangements to care for such traffic shall be Contractor's responsibilities. All expenses involved in the maintenance of traffic by way of detours shall be borne by Contractor.
- F. Contractor to act in an emergency: In an emergency affecting the safety of life or the Work or of adjoining property, Contractor is permitted to act, at its discretion, to prevent such threatened loss or injury, and Contractor shall so act if so authorized or instructed.
- G. No duty of safety by Owner: Nothing provided in this section shall be construed as imposing any duty upon Owner with regard to, or as constituting any express or implied assumption of control or responsibility over, Project site safety, or over any other safety conditions relating to employees or agents of Contractor or any of its Subcontractors, or the public.

3.6 INDEPENDENT CONTRACTOR

- A. The Contractor and Owner agree the Contractor is an independent contractor with respect to the services provided pursuant to this Contract. Nothing in this Contract shall be considered to create a relationship of employer and employee between the parties hereto. Neither the Contractor nor any employee of the Contractor shall be entitled to any benefits accorded Owner employees by virtue of the services provided under this Contract. The Owner shall not be responsible for withholding or otherwise deducting federal income tax or social security or contributing to the State Industrial Insurance Program, or otherwise assuming the duties of an employer with respect to the Contractor, or any employees of the Contractor.

3.7 OPERATIONS, MATERIAL HANDLING, AND STORAGE AREAS

- A. Contractor shall confine all operations, including storage of materials, to Owner-approved areas.
- B. Contractor shall be responsible for the proper care and protection of its materials and equipment delivered to the Project site.
- C. Contractor shall protect and be responsible for any damage or loss to the Work, or to the materials or equipment until the date of Final Acceptance, and shall repair or replace without cost to Owner any damage or loss that may occur.

3.8 PRIOR NOTICE OF EXCAVATION

- A. Prior to any excavation Contractor shall engage a locate service for all underground facilities or utilities. Contractor shall pay all fees for locator services and pay for all damages caused by excavation.

3.9 UNFORESEEN PHYSICAL CONDITIONS

- A. Notice requirement for concealed or unknown conditions: If Contractor encounters conditions at the site which are subsurface or otherwise concealed physical conditions which differ materially from those indicated in the Contract Documents, or unknown physical conditions of an unusual nature which differ materially from those ordinarily found to exist and generally recognized as inherent in construction activities of the character provided for in the Contract Documents, then Contractor shall give written notice to Owner promptly and in no event later than seven Days after the first observance of the conditions. Conditions shall not be disturbed prior to such notice.
- B. Adjustment in Contract Time and Contract Sum: If such conditions differ materially and cause a change in Contractor's cost of, or time required for, performance of any part of the Work, the Contractor may be entitled to an equitable adjustment in the Contract Time or Contract Sum, or both, provided it makes a request therefore as provided in Part 5.

3.10 PROTECTION OF EXISTING STRUCTURES, EQUIPMENT, VEGETATION, UTILITIES, AND IMPROVEMENTS

GENERAL CONDITIONS

- A. Contractor shall protect from damage all existing conditions, including soils, structures, equipment, improvements, utilities, and vegetation at or near the Project site; and on adjacent property of a third party, the locations of which are made known to or should be known by Contractor. Contractor shall repair any damage, including that to the property of a third party, resulting from failure to comply with the requirements of the Contract Documents, any defects of equipment, material, workmanship or design furnished by the Contractor, or failure by Contractor or subcontractor at any tier to exercise reasonable care in performing the Work. If Contractor fails or refuses to repair the damage promptly, Owner may have the necessary work performed and charge the cost to Contractor.
- B. New work which connects to existing work shall correspond in all respects with that to which it connects and/or be similar to existing work unless otherwise required by the Specifications.

3.11 MATERIAL AND EQUIPMENT

- A. All equipment, material, and articles incorporated into the Work shall be new and of the most suitable grade for the purpose intended, unless otherwise specifically provided in the Contract Documents. References in the Specifications to equipment, material, articles, or patented processes by trade name, make, or catalog number, shall be regarded as establishing a standard quality and shall not be construed as limiting competition. Contractor may, at its option, use any equipment, material, article, or process that, in the judgment of Owner, is equal to that named in the Specifications, unless otherwise specifically provided in the Contract Documents.
- B. Substitutions shall be considered where qualities and attributes including, but not limited to, cost, performance, weight, size, durability, visual effect, and specific features and requirements indicated are deemed equal or better by the Owner at the Owner's sole discretion. All requests for substitutions shall be made in writing to Owner and shall not be deemed to be approved unless approved in writing by Owner.

3.12 CORRECTION OF NONCONFORMING WORK

- A. Contractor shall promptly correct Work found by Owner not to conform to the requirements of the Contract Documents, whether observed before or after Final Acceptance.
- B. If Contractor fails to correct nonconforming Work, Owner may replace, correct, or remove the nonconforming Work and charge the cost thereof to the Contractor.

3.13 CLEAN UP

- A. Contractor shall at all times keep the Project site, including hauling routes, infrastructures, utilities, and storage areas, free from accumulations of waste materials. Before completing the Work, Contractor shall remove from the premises its rubbish, tools, scaffolding, equipment, and materials. Upon completing the Work, Contractor shall leave the Project site in a clean, neat, and orderly condition satisfactory to Owner. If Contractor fails to clean up as provided herein, and after reasonable notice from Owner, Owner may do so and the cost thereof shall be charged to Contractor.

3.14 SUBCONTRACTORS AND SUPPLIERS

- A. Contractor shall utilize Subcontractors and suppliers which are experienced and qualified.
- B. By appropriate written agreement, Contractor shall require each Subcontractor to be bound to Contractor by terms of those Contract Documents, and to assume toward Contractor all the obligations and responsibilities which Contractor assumes toward Owner in accordance with the Contract Documents. Each Subcontract shall preserve and protect the rights of Owner in accordance with the Contract Documents with respect to the Work to be performed by the Subcontractor so that subcontracting thereof will not prejudice such rights. Contractor shall require each Subcontractor to enter into similar agreements with Sub-subcontractors. However, nothing in this paragraph shall be construed to alter the contractual relations between Contractor and its Subcontractors with respect to insurance or bonds.
- C. Contractor shall schedule, supervise, and coordinate the operations of all Subcontractors. No Subcontracting of any of the Work shall relieve Contractor from its responsibility for the performance of the Work in accordance with the Contract Documents or any other obligations of the Contract Documents.

GENERAL CONDITIONS

- D. It is the Contractor's responsibility to pay its Subcontractors and material suppliers on a timely basis. The Owner reserves the right to withhold a portion of the Contractor's payment if the Contractor fails to make timely payments to the Subcontractors and material suppliers.
- E. The Contract Documents shall not be construed to create a contractual relationship of any kind between the Owner and any Subcontractor; or any persons other than Owner and Contractor.
- F. The Contractor shall not enter into any subcontract with any subcontractor who has been suspended or debarred from participating in contracting programs by any agency of the United States Government or by any state, territory, or municipality.

3.15 INDEMNIFICATION

- A. The Contractor hereby agrees to indemnify, defend, and hold harmless the Authority, its successors and assigns, director, officers, officials, employees, agents, partners and volunteers (all foregoing singly and collectively (Indemnities")) from a and against any and all claims, losses, harm costs, liabilities, damages and expenses, including, but not limited to, reasonable attorney's fees arising or resulting from the performance of the services, or the acts or omissions of the Contractor its successors, and assigns, employees, subcontractors or anyone acting on the contractor's behalf in connection with this Contract or its performance of this Contract.
- B. Provided, however, that the Contractor will not be required to indemnify, defend, or save harmless the indemnitee as provided in the preceding paragraphs of this section if the claim, suit, or action for injuries, death, or damages is caused by the sole negligence of the indemnitee. Where such claims, suites, or actions result from the concurrent negligence of (a) the indemnitee or the indemnitee's agents or employees and (b) the Contractor or the Contractor's agent or employee, the indemnity provisions provided in the proceeding paragraphs of this section shall be valid and enforceable only to the extent of the Contractor's negligence or the negligence of its agents and employees..
- C. The foregoing indemnity is specifically and expressly intended to constitute a waiver of the Contractor's immunity under Washington's Industrial Insurance act, RCW Title 51. The parties acknowledge that these provisions were specifically negotiated and agreed upon by them. If any portion of this indemnity clause is invalid or unenforceable, it shall be deemed excised and the remaining portions of the clause shall be given full force and effect.
- D. The Contractor hereby agrees to require all its Subcontractors or anyone acting under its direction or control or on its behalf in connection with or incidental to the performance of this Contract to execute an indemnity clause identical to the preceding clause, specifically naming the Owner as indemnity, and failure to do so shall constitute a material breach of this Contract by the Contractor.

3.16 PROHIBITION AGAINST LIENS

- A. The Contractor is prohibited from placing a lien on the Owner's property. This prohibition shall apply to all subcontractors of any tier and all materials suppliers, in accordance with RCW 35.82.190.

3.17 DAMAGES FOR FAILURE TO ACHIEVE TIMELY COMPLETION

- A. Liquidated Damages
 - 1. Timely performance and completion of the Work is essential to Owner and time limits stated in the Contract Documents are of the essence. The liquidated damage amounts set forth will be assessed not as a penalty, but as liquidated damages for breach of the Contract Documents. This amount is fixed and agreed upon by and between the Contractor and Owner because of the impracticability and extreme difficulty of fixing and ascertaining the actual damages the Owner would in such event sustain. This amount shall be construed as the actual amount of damages sustained by the Owner, and may be retained by the Owner and deducted from any payments to the Contractor.
 - 2. If different completion dates are specified in the contract for separate parts or stages of the work, the amount of liquidated damages shall be assessed on those parts or stages which are delayed.

GENERAL CONDITIONS

3.18 WAIVER AND SEVERABILITY

- A. The failure or delay of either party to insist on performance of any provision of the Contract, or to exercise any right or remedy available under the Contract, shall not be construed as a waiver of that provision, right, or remedy in any later instance. Waiver or breach of any provision of the Contract shall not be construed to be a waiver of any other or subsequent breach and shall not be construed to be a modification of the terms of the Contract, unless the Contract is modified pursuant to the Clause entitled "Contract Modifications" herein.
- B. If any provision of the Contract is or becomes void or unenforceable by operation of law, the remaining provisions shall be valid and enforceable.

PART 4 - PAYMENTS AND COMPLETION

4.1 CONTRACT SUM

- A. The Contract Sum shall include all taxes imposed by law and properly chargeable to the Project, including sales tax. The Contractor shall pay the WSST to the Department of Revenue and shall furnish proof of payment to the Owner if requested.
- B. The retail sales tax does not apply to the gross contract price.
- C. Prime and subcontractors are required to pay retail sales tax upon all purchases of materials, including prefabricated and precast items, equipment, leases or rentals of tools, consumables, and other tangible personal property which is installed, applied, attached, or otherwise incorporated in their work.

4.2 APPLICATION FOR PAYMENT

- A. At monthly intervals, unless determined otherwise by Owner, Contractor shall submit to Owner an Application for Payment for Work completed in accordance with the Contract Documents. Each application shall be supported by such substantiating data as Owner may require.
- B. Each invoice shall include the following statement: "I hereby certify that the items listed are proper charges for materials, merchandise or services provided to the King County Housing Authority, and that all goods and/or services have been provided; that prevailing wages have been paid in accordance with the approved statements of intent filed with the Department of Labor and Industries; and that sub-contractors and/or suppliers have been paid, less earned retainage, as their interest appears in the last payment received."
- C. Coordinate preparation of the Schedule of Values with preparation of Contractor's Construction Schedule. Each Application for Payment shall be consistent with previous applications and payments.
- D. Owner shall retain 5% of the amount of each progress payment until 45 Days after Final Acceptance and receipt of all documents required by law or the Contract Documents including releases by Washington State Employment Security Department and Washington State Department of Revenue and Department of Labor & Industries.
- E. Waivers of Lien: With each Application for Payment, submit conditional waivers lien from every entity who is lawfully entitled to file a lien arising out of the Contract and related to the Work covered by the payment.
 - 1. Submit partial waivers on each item for amount requested, before deduction for retainage, on each item.
 - 2. When an application shows completion of an item, submit final or full waivers.
 - 3. Owner reserves the right to designate which entities involved in the Work must submit waivers.
 - a. Submit final Application for Payment with or preceded by final waivers from every entity involved with performance of the Work covered by the application who is lawfully entitled to a lien.
- F. Final Payment Application: Submit final Application for Payment with releases and close out supporting documentation.

GENERAL CONDITIONS

- G. Approved payments shall be mailed to the Contractor within 30 days.

4.3 FINAL COMPLETION, ACCEPTANCE, AND PAYMENT

- A. The Owner shall make a final inspection of the Work on receipt of (1) written notice from the Contractor that the Work is ready for final inspection and (2) a final Application for Payment. When the Owner finds the Work acceptable and fully performed under the Contract Documents, and the Contractor has delivered to the Owner all warranties, permits, and operations manuals, the Owner will issue a Notice of Final Completion.
- B. Acceptance of final payment by Contractor, or any Subcontractor, shall constitute a waiver and release to Owner of all claims by Contractor, or any such Subcontractor, for an increase in the Contract Sum or the Contract Time, and for every act or omission of Owner relating to or arising out of the Work, except for those Claims made in accordance with the procedures, including the time limits, set forth in PART 7 - .

PART 5 - CHANGES

5.1 CHANGE IN THE WORK

- A. Owner may, at any time and without notice to Contractor's surety, order additions, deletions, revisions, or other changes in the Work. These changes in the Work shall be incorporated into the Contract Documents through the execution of Change Orders. If any change in the Work ordered by Owner causes an increase or decrease in the Contract Sum or the Contract Time, an equitable adjustment shall be made as provided in 5.2 and 5.3.
- B. Pending agreement on the terms of the Change Order, Owner may direct Contractor to proceed immediately with the Change Order Work. Contractor shall not proceed with any change in the Work until it has obtained Owner's written approval.
- C. The Contractor agrees that any change in the Contract Amount or Contract Time provided in a Change Order is full and complete compensation to the Contractor for the change(s) to the work, deleted work, modified work, direct or indirect impact on the Contractor's schedule, and for any equitable adjustment or time extension to which the Contractor may be entitled to in the Change Order, pursuant to the Contract between the Owner and Contractor.

5.2 CHANGE IN THE CONTRACT SUM

- A. Change Order Pricing - Fixed Price: When the fixed price or time and materials method is used to determine the value of any Work covered by a Change Order, or of a request for an equitable adjustment in the Contract Sum, the following procedures shall apply:
 - 1. Contractor's Change Order proposal, or request for adjustment in the Contract Sum, shall be accompanied by a complete itemization of the costs, including labor, material, subcontractor costs, and overhead and profit. The costs shall be itemized in the manner set forth below, and shall be submitted on breakdown sheets with documentation in a form approved by Owner.
 - 2. Any request for adjustment of Contract Sum shall include only the following items:
 - a. Craft labor costs for Contractors and Subcontractors.
 - 1) Basic wages and benefits: Hourly rates and benefits according to applicable prevailing wages.
 - 2) Direct supervision shall not to exceed 15% of the cost of direct labor. No supervision markup shall be allowed for a working supervisor's hours.
 - 3) Worker's Insurance. Direct contributions to the State for industrial insurance, medical aid, and supplemental pension by the class and rates established by L&I.
 - 4) Federal Insurance. Direct contributions required by the Federal Insurance Compensation Act; Federal Unemployment Tax Act; and the State Unemployment Compensation Act.
 - 5) Safety and small tools: 4% of the sum of the amounts calculated in (1), (2), and (3) above.

GENERAL CONDITIONS

- b. Material Costs: Material costs and applicable sales tax shall be developed from actual known costs, supplier quotations or standard industry pricing guides and shall consider all available discounts. Freight costs, express charges, or special delivery charges shall be itemized.
- c. Equipment Costs: Itemization of the type of equipment and the estimated or actual length of time the equipment appropriate for the Work is or will be used on the change in the Work. Costs will be allowed for equipment and applicable sales tax only if used solely for the changed Work, or for additional rental costs actually incurred by the Contractor. The Date Quest Rental Rate (Blue Book) shall be used as a basis for establishing rental rates of equipment not listed in the above sources. The maximum rate for standby equipment shall not exceed 50% of the applicable rate.
- d. Allowance for Overhead: This allowance shall compensate Contractor for all noncraft labor, temporary construction facilities, field engineering, schedule updating, as-built drawings, home office cost, B&O taxes, office engineering, estimating costs, additional overhead because of extended time and any other cost incidental to the change in the Work. This allowance shall be strictly limited in all cases an amount not to exceed the following:
 - 1) For Contractor, for any Work actually performed by Contractor's own forces, 16% of the cost.
 - 2) For each Subcontractor (including lower tier subcontractors), for any Work actually performed by its own forces, 16% of the cost.
 - 3) For Contractor, for any Work performed by its Subcontractor(s), 6% of the amount due each Subcontractor.
 - 4) For each Subcontractor, for any Work performed by its Subcontractor(s) of any lower tier, 5% of the amount due the sub-Subcontractor.
- e. Allowance for Profit:
 - 1) For Contractor or Subcontractor of any tier for work performed by their forces, 5% of the cost developed in accordance with subsections a, b & c above.
 - 2) For Contractor or Subcontractor of any tier for work performed by a subcontractor of a lower tier, 5% of the Subcontractor cost.
- f. Insurance or Premium: The costs of any change or additional premium of Contractor's liability insurance or bond premium arising directly from the changed Work. The costs of any change in insurance shall be added after overhead and profit are calculated.

B. Change Order Pricing - Unit Prices

- 1. Work on a unit-price basis as stated in the Specifications and at the price submitted in the Bid Form or as subsequently modified.
 - a. Unit prices shall include reimbursement for all direct and indirect costs of the Work, including overhead and profit, bond premium, and insurance costs; and
 - b. Quantities must be supported by field measurement verified by Owner.

5.3 CHANGE IN THE CONTRACT TIME

- A. The Contract Time shall only be changed by a Change Order. Contractor shall immediately notify Owner, and shall include any request for a change in the Contract Time in its Change Order proposal.
- B. If the time of Contractor's performance is changed due to an act of Force Majeure, Contractor shall request for an equitable adjustment in the Contract Time in writing within 24-hours of the occurrence.

PART 6 - CLAIMS AND DISPUTE RESOLUTION

6.1 CLAIMS PROCEDURE

- A. If the parties fail to reach agreement regarding any dispute arising from the Contract Documents, Contractor's only remedy shall be to file a Claim with Owner within 30 Days from Owner's final offer.

GENERAL CONDITIONS

- B. The Claim shall be deemed to cover all changes in cost and time (including direct, indirect, impact, and consequential) to which Contractor may be entitled. It shall be fully substantiated and documented.
- C. After Contractor has submitted a fully-documented Claim, Owner shall respond, in writing, to Contractor with a decision within 30 Days from the date the Claim is received.
- D. Contractor shall proceed with performance of the Work pending final resolution of any Claim. Owner's written decision as set forth above shall be final and conclusive as to all matters set forth in the Claim.
- E. Any Claim of the Contractor against the Owner for damages, additional compensation, or additional time, shall be conclusively deemed to have been waived by the Contractor unless timely made in accordance with the requirements of this section.

6.2 ARBITRATION

- A. If Contractor disagrees with Owner's decision rendered in accordance with paragraph 6.1C, Contractor shall provide Owner with a written demand for arbitration. No demand for arbitration of any such Claim shall be made later than 30 Days after the date of Owner's decision on such Claim; failure to demand arbitration within said 30 Day period shall result in Owner's decision being final and binding upon Contractor and its Subcontractors.
 - 1. Notice of the demand for arbitration shall be filed with the American Arbitration Association (AAA), with a copy provided to Owner. The parties shall negotiate or mediate under the Voluntary Construction Mediation Rules of the AAA, or mutually acceptable service.
- B. All Claims arising out of the Work shall be resolved by arbitration. The judgment upon the arbitration award may be entered, or review of the award may occur, in the superior court having jurisdiction thereof. No independent legal action relating to or arising from the Work shall be maintained.

6.3 CLAIMS AUDITS

- A. All Claims filed against Owner shall be subject to audit at any time following the filing of the Claim. Failure of Contractor, or Subcontractors of any tier, to maintain and retain sufficient records to allow Owner to verify all or a portion of the Claim or to permit Owner access to the books and records of Contractor, or Subcontractors of any tier, shall constitute a waiver of the Claim and shall bar any recovery.
 - 1. In support of Owner audit of any Claim, Contractor shall promptly make available to Owner all records relating to the Work.

PART 7 - TERMINATION OF THE WORK

7.1 TERMINATION BY OWNER FOR CAUSE

- A. Owner may, upon a written Notice to Contractor and to its surety, terminate (without prejudice to any right or remedy of Owner) the Work, or any part of it, for cause upon the occurrence of any one or more of the following events:
 - 1. Contractor fails to prosecute the Work or any portion thereof with sufficient diligence to ensure Completion of the Work within the Contract Time;
 - 2. Contractor is adjudged bankrupt, makes a general assignment for the benefit of its creditors, or a receiver is appointed on account of its insolvency;
 - 3. Contractor fails in a material way to replace or correct Work not in conformance with the Contract Documents;
 - 4. Contractor repeatedly fails to supply skilled workers or proper materials or equipment;
 - 5. Contractor repeatedly fails to make prompt payment due to Subcontractors, suppliers, or for labor;
 - 6. Contractor materially disregards or fails to comply with laws, ordinances, rules, regulations, or orders of any public authority having jurisdiction; or
 - 7. Contractor is otherwise in material breach of any provision of the Contract Documents.

GENERAL CONDITIONS

- B. Upon termination, Owner may at its option:
 - 1. Take possession of the Project site and take possession of or use all materials, equipment, tools, and construction equipment and machinery thereon owned by Contractor to maintain the orderly progress of, and to finish, the Work;
 - 2. Finish the Work by whatever other reasonable method it deems expedient.
- C. Owner's rights and duties upon termination are subject to the prior rights and duties of the surety, if any, obligated under any bond provided in accordance with the Contract Documents.
- D. When Owner terminates the Work in accordance with this section, Contractor shall take the actions set forth in paragraph 7.2B, and shall not be entitled to receive further payment until the Work is accepted.
- E. If the unpaid balance of the Contract Sum exceeds the cost of finishing the Work, including compensation for A/E services and expenses made necessary thereby and any other extra costs or damages incurred by Owner in completing the Work, or as a result of Contractor's actions, such excess shall be paid to Contractor. If such costs exceed the unpaid balance, Contractor shall pay the difference to Owner. Contractor shall also be liable for liquidated damages until such reasonable time as may be required for Completion. These obligations for payment shall survive termination.
- F. Termination of the Work in accordance with this section shall not relieve Contractor or its surety of any responsibilities for Work performed.
- G. If Owner terminates Contractor for cause, and it is later determined that none of the circumstances set forth in 7.1A exist, then such termination shall be deemed a termination for convenience pursuant to 7.2.

7.2 TERMINATION BY OWNER FOR CONVENIENCE

- A. Owner may, upon Notice, terminate (without prejudice to any right or remedy of Owner) the Work, or any part of it, for the convenience of Owner.
- B. Unless Owner directs otherwise, after receipt of a Notice of termination for either cause or convenience, Contractor shall promptly:
 - 1. Stop performing Work on the date and as specified in the notice of termination;
 - 2. Place no further orders or subcontracts for materials, equipment, services or facilities, except as may be necessary for completion of such portion of the Work as is not terminated;
 - 3. Cancel all orders and subcontracts, upon terms acceptable to Owner, to the extent that they relate to the performance of Work terminated;

PART 8 - MISCELLANEOUS PROVISIONS

8.1 RECORDS KEEPING AND REPORTING

- A. The Contractor and all Subcontractors shall maintain accounts and records in accordance with State Auditor's procedures, including personnel, property, financial and programmatic records which sufficiently and properly reflect all direct and indirect costs of any nature expended and services performed in the performance of this Contract and other such records as may be deemed necessary by the Owner to ensure proper accounting for all funds contributed by the Owner to the performance of this Contract and compliance with this Contract.
- B. The Contractor, and its Subcontractors, shall maintain these records for a period of six (6) years after the date of Final Acceptance.

8.2 AUDITS AND INSPECTIONS

- A. The records and documents with respect to all matters covered by this Contract shall be subject at all times to inspection, review or audit by the Owner or any other government agency so authorized by law during the performance of this Contract. The Owner shall have the right to an annual audit of the Contractor's financial statement and condition.

GENERAL CONDITIONS

8.3 ORGANIZATION CONFLICTS OF INTEREST

- A. The Contractor warrants that to the best of its knowledge and belief and except as otherwise disclosed, it does not have any organizational conflict of interest which is defined as a situation in which the nature of work under this Contract and the Contractor's organizational, financial, contractual or other interests are such that:
 - 1. Award of the Contract may result in an unfair competitive advantage; or
 - 2. The Contractor's objectivity in performing the Contract work may be impaired.
- B. The Contractor agrees that if after award they discover an organizational conflict of interest with respect to this Contract, they shall make an immediate and full disclosure in writing to the Contracting Officer, which shall include a description of the action, which the Contractor has taken or intends to take to eliminate or neutralize the conflict. The Owner may, however, terminate the Contract if it deems the action to be in the best interest of the Owner.
- C. In the event the Contractor was aware of an organizational conflict of interest before the award of this Contract and intentionally did not disclose the conflict to the Contracting Officer, the Owner may terminate the Contract for default.
- D. The provisions of this Clause shall be included in all subcontracts and consulting agreements wherein the work to be performed is similar to the services provided by the Contractor. The Contractor shall include in such subcontracts and consulting agreements any necessary provisions to eliminate or neutralize conflicts of interest.

8.4 INTERESTS OF MEMBERS OF CONGRESS

- A. No member of or delegate to the Congress of the United States of America shall be admitted to any share or part of this Contract or to any benefit to arise therefrom, but this provision shall not be construed to extend to this Contract if made with a corporation for its general benefit.

8.5 INTERESTS OF MEMBERS, OFFICERS, COMMISSIONERS AND EMPLOYEES, OR FORMER MEMBERS, OFFICERS AND EMPLOYEES

- A. No member, officer, or employee of the King County Housing Authority, no member of the governing body of the locality in which the project is situated, no member of the governing body in which the Owner was activated, and no other public official or such locality or localities who exercises any functions or responsibilities with respect to the project, shall, during his or her tenure, or for one year thereafter, have any interest, direct or indirect, in this Contract or the proceeds thereof.

BID FORM

PROJECT NAME AND LOCATION:

**Argyle Apartments
Window & Patio Door Replacement**

Contract Number: DW2300531

BID FORM

The undersigned, Legal Name of Bidder: _____

on this date: _____, 2023, having familiarized him/herself with the contract documents, site conditions, and has field verified all measurements contained in the project manual as prepared by the Owner, hereby proposes to furnish labor, materials and necessary equipment – all including, but not limited to, demolition, disposal, new installation and the required applicable taxes and fees to complete the work for the following bid amounts:

BASE BID _____ (\$ _____)
(Including sales tax indicated in Instructions to Bidders)

ADDENDA _____
Acknowledge receipt of any addenda by inserting the number(s) above

In submitting this bid, it is understood that the right is reserved by the Owner to reject any and all bids. The undersigned hereby agrees that this proposal shall be a valid and firm offer for a period of Sixty (60) calendar days from the date of Bid Opening.

Bidder agrees that Work will be substantially complete and ready for final payment in accordance with the Contract Documents on or before the date, within the number of calendar days indicated.

The undersigned Bidder hereby certifies that, within the three-year period immediately preceding the bid solicitation date for this Project, the bidder is not a “willful” violator, as defined in RCW 49.48.082, of any provision of chapters 49.46, 49.48, or 49.52 RCW, as determined by a final and binding citation and notice of assessment issued by the Department of Labor and Industries or through a civil judgment entered by a court of limited or general jurisdiction.

I certify (or declare) under penalty of perjury under the laws of the State of Washington that the foregoing is true and correct.

Signature of Bidder

Print Your Name

Submitted on _____ day of _____ 2023

City

State

BIDDER INFORMATION

BIDDER INFORMATION

Name of Bidder (Company): _____

Address: _____

Contact Name: _____

Phone Number: _____ Email Address: _____

Business Type: General Contractor () Other () (Please specify): _____

Bidder is a(n): Individual Partnership Joint Venture Incorporated in the state of _____

List business names & associated UBI # used by Bidder during the past 5 years if different than above:

Bidder has been in business continuously from: _____
Month, Year

Business License #: _____ Federal ID #: _____

Current UBI #: _____ Dept. of L&I Worker's Comp. Acct. #: _____

Bidder has experience in work "Similar in Scope and Complexity" comparable to that required for this Project:

As a prime contractor for _____ years. As a subcontractor for _____ years.

OWNER(S) OF COMPANY (List all owners):	OWNER'S SOCIAL SECURITY NUMBER (only required if sole proprietorship):

No. of regular full-time employees other than owner(s): _____

Indicate clearly the kind of work your company will actually perform in this project:

Approximate % of work your company will actually perform: _____

List the supervisory personnel to be employed by the Bidder and available for, and intended to, work on this project:

<u>Name</u>	<u>Title</u>	<u>How Long With Bidder</u>

BIDDER INFORMATION

SUBCONTRACTORS

Do you intend to use Subcontractor(s) in this project? Yes No (If yes, you must show the name of the subcontractors. Attach additional pages as necessary.)

Subcontractors Name	Subcontractor's UBI#	Phone Number	Trade	Years in Business
1.				
2.				
3.				
4.				
5.				

BIDDER'S EXPERIENCE

Projects successfully supervised and completed by your company for work of similar scope and value as specified in bid documents in the last 5 years. Attach additional pages as necessary.

Name of Project	Completion Date	Duration (Months)	Nature of Work	Amount of Contract
1.				
2.				
3.				
4.				
5.				

Owner's Name (of project listed above)	Project Address	Contact Person	Phone Number
1.			
2.			
3.			
4.			
5.			

Has Bidder ever been found guilty of violating any State or Federal employment laws? No Yes
If yes, give details & attach additional pages as necessary:

Has Bidder ever filed for protection under any provision of the federal bankruptcy laws or state insolvency laws?
 No Yes If yes, give details & attach additional pages as necessary:

CONTRACT FORM

This Contract is entered into by and between the King County Housing Authority, hereinafter referred to as the "Owner" whose principal office is located at 600 Andover Park West, Seattle, WA 98188 and [Name of Contractor], referred to as the "Contractor", whose principal office is located at [Contractor's Address].

IN CONSIDERATION OF the mutual benefits and conditions hereinafter contained, the parties hereto agree as follows:

1.1 Contract Documents

A. The provisions set forth in the Contract Documents are hereby incorporated into and made part of the Contract. Contractor acknowledges receipt and review of all Contract Documents applicable to performance of the work. The Contract shall consist of the following component parts:

1. This Instrument
2. Addenda
3. Specifications
4. Plans
5. Bid Form
6. Pre-Bid Agenda
7. General Conditions
8. Instructions to Bidders
9. Prevailing Wage Rates

1.2 Scope of Services to be Performed by the Contractor: The Contractor shall provide all labor, materials, tools, equipment, transportation, supplies, and incidentals required to complete the work in accordance with the Contract Documents for:

Project: Argyle Apartments Window & Patio Door Replacement

Contract No.: DW2300531

1.3 Compensation: The total amount of the Contract shall be [\$\$\$] dollars and [¢¢] cents (\$[\$\$\$.\$\$]) subject to additions and deductions provided therein.

1.4 Duration of Contract: The Contractor shall commence work after receipt of Notice to Proceed, follow the schedule specified in the contract documents, and all work must be completed within sixty (60) consecutive calendar days from the date of the Notice to Proceed unless sooner terminated pursuant to the General Conditions. Upon expiration of the original Contract term, the Contract, at the Owner's sole discretion, may be extended for a period determined by the Owner.

1.5 Liquidated Damages: Timely performance and completion of the Work is essential to Owner and time limits stated in the Contract Documents are of the essence. If Completion of the Work does not occur within the Contract Time, the Contractor agrees that Liquidated Damages in the amount of **\$250.00** per day will be assessed for each calendar day that the Contractor exceeds the time for completion.

The individuals signing this Contract warrant and represent for themselves and for their respective organizations that they are duly authorized to sign this Contract and that upon such signing their respective organizations are bound thereby.

DATED this _____ day of _____, 2023

Contractor

Owner

President/Owner

Robin Walls
Executive Director
KING COUNTY HOUSING AUTHORITY

CERTIFICATE OF INSURANCE

DATE(MM/DD/YY)

Issue Date

PRODUCER Vendor's Insurance Agent Street Address City, State, Zip Phone Number	THIS CERTIFICATE IS ISSUED AS A MATTER OF INFORMATION ONLY AND CONFERS NO RIGHTS UPON THE CERTIFICATE HOLDER. THIS CERTIFICATE DOES NOT AMEND, EXTEND OR ALTER THE COVERAGE AFFORDED BY THE POLICIES BELOW.
---	--

COMPANIES AFFORDING COVERAGE	
COMPANY A	ABC Insurance Company

INSURED Vendor Name Street Address City, State, Zip	<table border="1" style="width: 100%; border-collapse: collapse;"> <tr> <td style="width: 15%; text-align: center;">COMPANY B</td> <td>DEF Insurance Company</td> </tr> <tr> <td style="width: 15%; text-align: center;">COMPANY C</td> <td>GHI Insurance Company</td> </tr> <tr> <td style="width: 15%; text-align: center;">COMPANY D</td> <td></td> </tr> </table>	COMPANY B	DEF Insurance Company	COMPANY C	GHI Insurance Company	COMPANY D	
COMPANY B	DEF Insurance Company						
COMPANY C	GHI Insurance Company						
COMPANY D							

COVERAGES
 THIS IS TO CERTIFY THAT THE POLICIES OF INSURANCE LISTED BELOW HAVE BEEN ISSUED TO THE INSURED NAMED ABOVE FOR THE POLICY PERIOD INDICATED. NOTWITHSTANDING ANY REQUIREMENT, TERM OR CONDITION OF ANY CONTRACT OR OTHER DOCUMENT WITH RESPECT TO WHICH THIS CERTIFICATE MAY BE ISSUED OR MAY PERTAIN, THE INSURANCE AFFORDED BY THE POLICIES DESCRIBED HEREIN IS SUBJECT TO ALL THE TERMS, EXCLUSIONS AND CONDITIONS OF SUCH POLICIES. LIMITS SHOWN MAY HAVE BEEN REDUCED BY PAID CLAIMS.

CO LTR	TYPE OF INSURANCE	POLICY NUMBER	POLICY EFFECTIVE DATE (MM/DD/YY)	POLICY EXPIRATION DATE (MM/DD/YY)	LIMITS	
A	GENERAL LIABILITY	XXX123	01/01/00	01/01/01	GENERAL AGGREGATE	2,000,000
	<input checked="" type="checkbox"/> COMMERCIAL GENERAL LIABILITY				PRODUCTS-COMP/OP AGG	1,000,000
	<input type="checkbox"/> CLAIMS MADE <input checked="" type="checkbox"/> OCCUR				PERSONAL & ADV INJURY	1,000,000
	<input type="checkbox"/> OWNER'S & CONTRACTOR'S PROT				EACH OCCURRENCE	1,000,000
					FIRE DAMAGE (Any one fire)	50,000
					MED EXP (Any one person)	5,000
B	AUTOMOBILE LIABILITY	XXX456	01/01/00	01/01/01	COMBINED SINGLE LIMIT	1,000,000
	<input checked="" type="checkbox"/> ANY AUTO				BODILY INJURY (Per person)	
	<input type="checkbox"/> ALL OWNED AUTOS				BODILY INJURY (Per accident)	
	<input type="checkbox"/> SCHEDULED AUTOS				PROPERTY DAMAGE	
<input checked="" type="checkbox"/> HIRED AUTOS						
<input type="checkbox"/> NON-OWNED AUTOS						
GARAGE LIABILITY					AUTO ONLY-EA ACCIDENT	
<input type="checkbox"/> ANY AUTO					OTHER THAN AUTO ONLY:	
					EACH ACCIDENT	
					AGGREGATE	
EXCESS LIABILITY					EACH OCCURRENCE	
<input type="checkbox"/> UMBRELLA FORM					AGGREGATE	
<input type="checkbox"/> OTHER THAN UMBRELLA FORM						
C	WORKERS' COMPENSATION AND EMPLOYER'S LIABILITY	XXX789	01/01/00	01/01/01	<input checked="" type="checkbox"/> STATUTORY LIMITS	
	THE PROPRIETOR/ PARTNERS/EXECUTIVE OFFICERS ARE: <input type="checkbox"/> INCL <input type="checkbox"/> EXCL				EACH ACCIDENT	1,000,000
					DISEASE-POLICY LIMIT	1,000,000
					DISEASE-EACH EMPLOYEE	1,000,000
OTHER						

DESCRIPTION OF OPERATIONS/LOCATIONS/VEHICLES/SPECIAL ITEMS
Security Properties Residential and King County Housing Authority are named as additional insureds with respect to above general liability and auto coverages.
Re: Contract #DW2300531 at Argyle Apartments located at 2517 South 316th Lane, Federal Way, WA 98003.

CERTIFICATE HOLDER Security Properties Residential and King County Housing Authority 600 Andover Park West Seattle, WA 98188-3326	CANCELLATION SHOULD ANY OF THE ABOVE DESCRIBED POLICIES BE CANCELED BEFORE THE EXPIRATION DATE THEREOF, THE ISSUING COMPANY WILL ENDEAVOR TO MAIL 30 DAYS WRITTEN NOTICE TO THE CERTIFICATE HOLDER NAMED TO THE LEFT, BUT FAILURE TO MAIL SUCH NOTICE SHALL IMPOSE NO OBLIGATION OR LIABILITY OF ANY KIND UPON THE COMPANY, ITS AGENTS OR REPRESENTATIVES. AUTHORIZED REPRESENTATIVE Signature of Insured's Agent
ACORD 25-S (3/93)	ACORD CORPORATION 1993

PROVIDE

**GENERAL LIABILITY
ENDORSEMENT**

and

**AUTO LIABILITY
ENDORSEMENT**